

BLOWER REPLACEMENT KIT

**INSTALLATION INSTRUCTIONS FOR BLOWER REPLACEMENT KIT
(612793-39, -40, -41; 28A74, 28A75, 28A76) USED WITH LC/LG/LH/LD 078-152 UNITS**

Shipping and Packing List

Package 1 of 1 contains:

- 1- Blower assembly
- 1- Wire Harness
- Bag assembly containing:
 - 5- Primary limit switches (S10)
 - Wire Ties
 - Installation Instructions

CAUTION

As with any mechanical equipment, personal injury can result from contact with sharp sheet metal edges. Be careful when you handle this equipment.

Application

This blower assembly replacement kit is used on LC/LG/LH/LD 078-152 units. See TABLE 1.

TABLE 1
LGM/LCM 092-150
LGT/LCT/LHT/LDT 078-152

Cat. #	Part #	Voltage
28A74	612793-39	Y
28A75	612793-40	G
28A76	612793-41	J

Replace Blower Motor

Direct-drive motor may not immediately stop when power is interrupted to the Unit Controller. Disconnect unit power before opening the blower compartment. The Controller's digital inputs must be used to shut down the blower. See Unit Controller manual for operation sequences.

- 1 - Disconnect electrical power to unit. Wait five minutes before continuing service procedures to avoid electrical shock. This will allow internal capacitors time to fully discharge.
- 2 - Open access panels. See FIGURE 1.
- 3 - Disconnect B3 Modbus connection and PT6 connection (LCM/LGM only) in the blower section. See FIGURE 2.
- 4 - Disconnect P48 in the controls area. See FIGURE 4.
- 5 - Cut wire ties where necessary and pull P48 wiring harness from control area into blower section.

WARNING

To prevent serious injury or death:

- 1- Lock-out/tag-out before performing maintenance.
- 2- If system power is required (e.g., smoke detector maintenance), disable power to blower, remove fan belt where applicable, and ensure all controllers and thermostats are set to the "OFF" position before performing maintenance.
- 3- Always keep hands, hair, clothing, jewelry, tools, etc., away from moving parts.

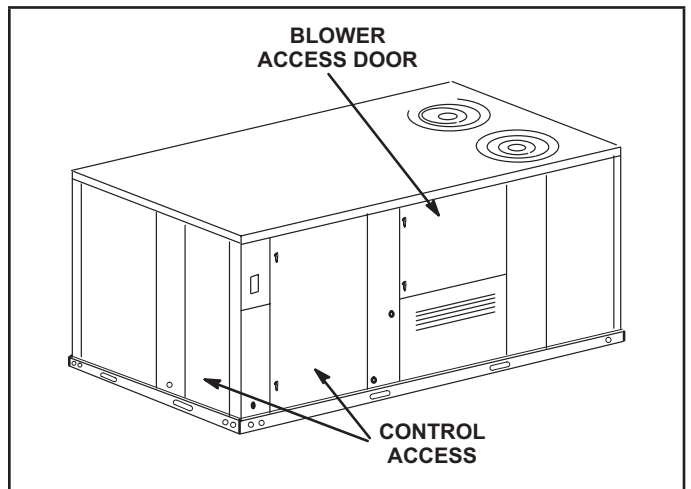

FIGURE 1

WARNING

Improper installation, adjustment, alteration, service or maintenance can cause property damage, personal injury or loss of life. Installation and service must be performed by a licensed professional installer (or equivalent), service agency or the gas supplier.

- 7 - Remove four screws securing blower assembly to unit. See FIGURE 7.
- 8 - If unit was equipped with a blower proving switch, remove switch from existing blower housing. Attach the proving switch to replacement blower assembly in the same manner it was removed.
- 9 - *LCM/LGM Units Only* - Disconnect the pressure tubing from PT6 pressure sensor. See FIGURE 3. Remove two screws and remove sensor/bracket assembly (note the orientation) from existing blower housing. Install the sensor/bracket onto the replacement blower assembly. Reattach the tubing in the same manner they were removed.

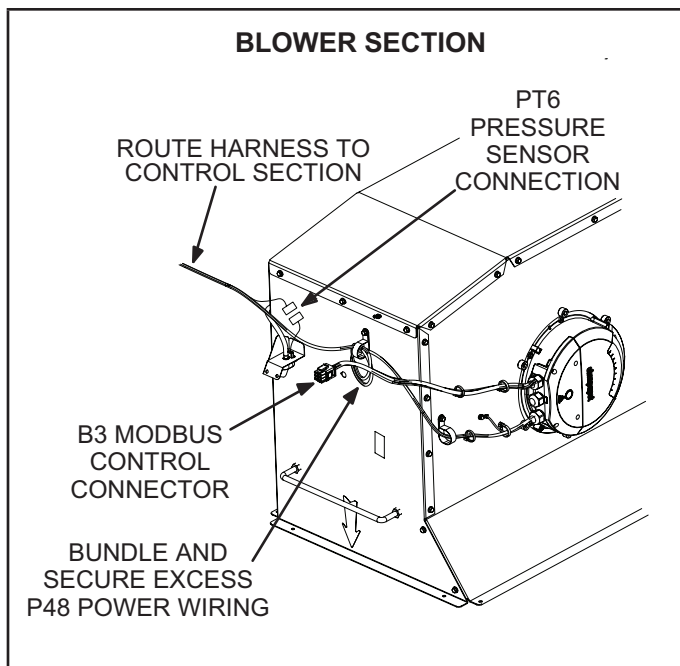

FIGURE 2

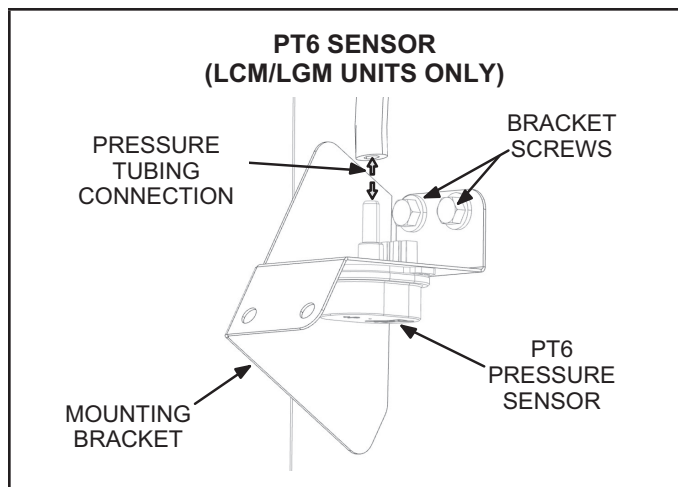

FIGURE 3

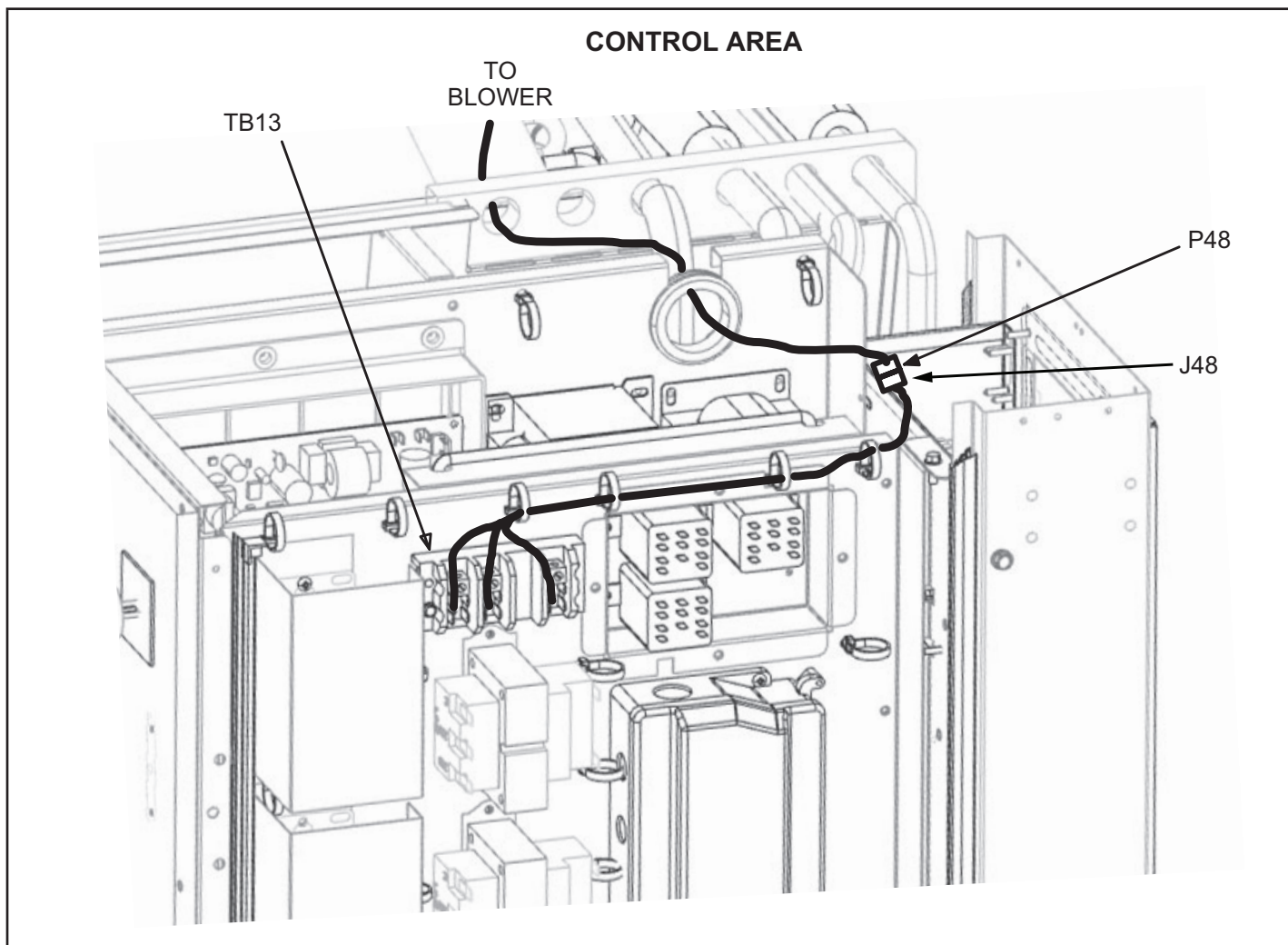

FIGURE 4

10 - Use the handle on the blower assembly to slide the assembly out of unit.

Note - Take note of the heat exchanger dimples before replacing the blower. See FIGURE 7. The appropriate replacement limit switches are determined by tri- or offset- dimples. See "Install New Limit Switch" section.

11 - Install replacement blower assembly flanges into rails on the blower deck in the same manner it was removed. Secure into place using four screws shown in FIGURE 7.

12 - Uncoil P48 wiring harness secured to replacement blower housing.

13 - Route P48 end of harness through unit to control area in the same manner it was removed.

14 - Connect B3 Modbus and PT6 connections as shown in FIGURE 2.

15 - Bundle harnesses and use wire ties to secure kit harnesses to unit harnesses in the same manner they were removed.

Remove T4 Transformer & F27 Fuses (If Necessary)

1 - Some 575V unit utilize a T4 transformer and F27 fuses. These parts and their associated wiring must be removed. See FIGURE 5.

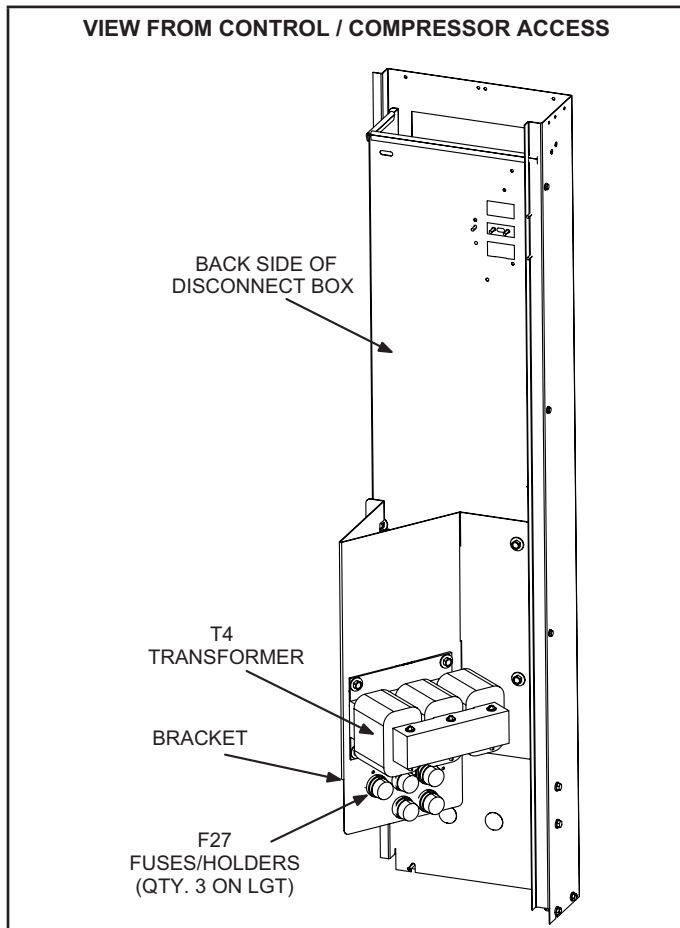

FIGURE 5

2 - Disconnect J293/P293, F27 Line, F27 Load, P294, and T4 Load connections in the controls area. See FIGURE 6.

3 - Remove T4 transformer, F27 fuses, and mounting bracket for transformer. Cut wire ties as need to remove associated harnesses. See FIGURE 5.

4 - Remove and discard existing J293 harness routed to TB13. See FIGURE 6.

5 - Install the provided replacement TB13 to J48 power harness by routing it per FIGURE 4.

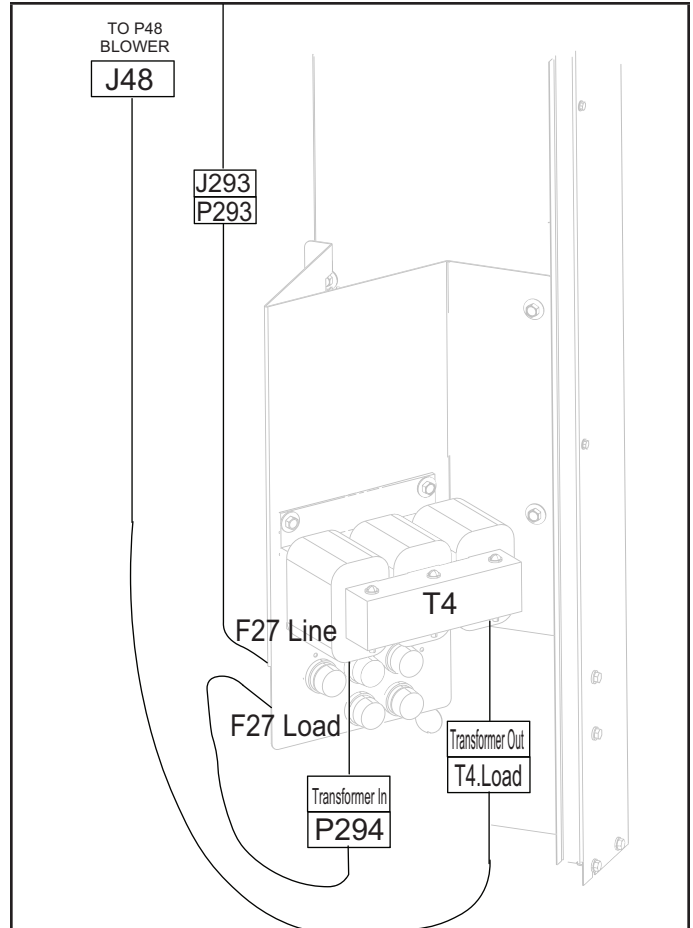

FIGURE 6

Install New Limit Switch (If Necessary)

If the gas heat limit switch is located on the right side of the blower, skip to next section (Connect Power Wiring). See FIGURE 8.

If limit switch is located on the left side of the blower, perform the following steps to install the appropriate limit on the right side. See FIGURE 8

- 1 - Remove and retain screws securing the limit switch on the left side of the blower assembly. Discard limit switch.
- 2 - Remove and retain screws securing the patch plate on the right side of the blower deck.
- 3 - Place the patch plate over the opening from the discarded switch on the left side of the blower. Secure with retained screws.

4 - Select the replacement switch as follows (see FIGURE 7 to view the heat exchanger dimples):

Tri-Dimple Heat Exchangers (FIGURE 9)

Std. Heat (6 tubes; 150°F) - 49L8901

Med. Heat (9 tubes; 175°F)- 49L8601

High Heat (11 tubes; 185°F)- 100847-10

Offset-Dimple Heat Exchangers (FIGURE 10)

Std. Heat (6 tubes; 150°F) - 100847-04

Med. Heat (9 tubes; 190°F) - 100847-12

High Heat (11 tubes; 185°F)- 100847-10

5 - Install the switch on the right side of the blower; secure with retained screws.

Cut the wire ties securing the discarded switch. Route to the replacement switch on the right side of the blower. Connect wires to terminals.

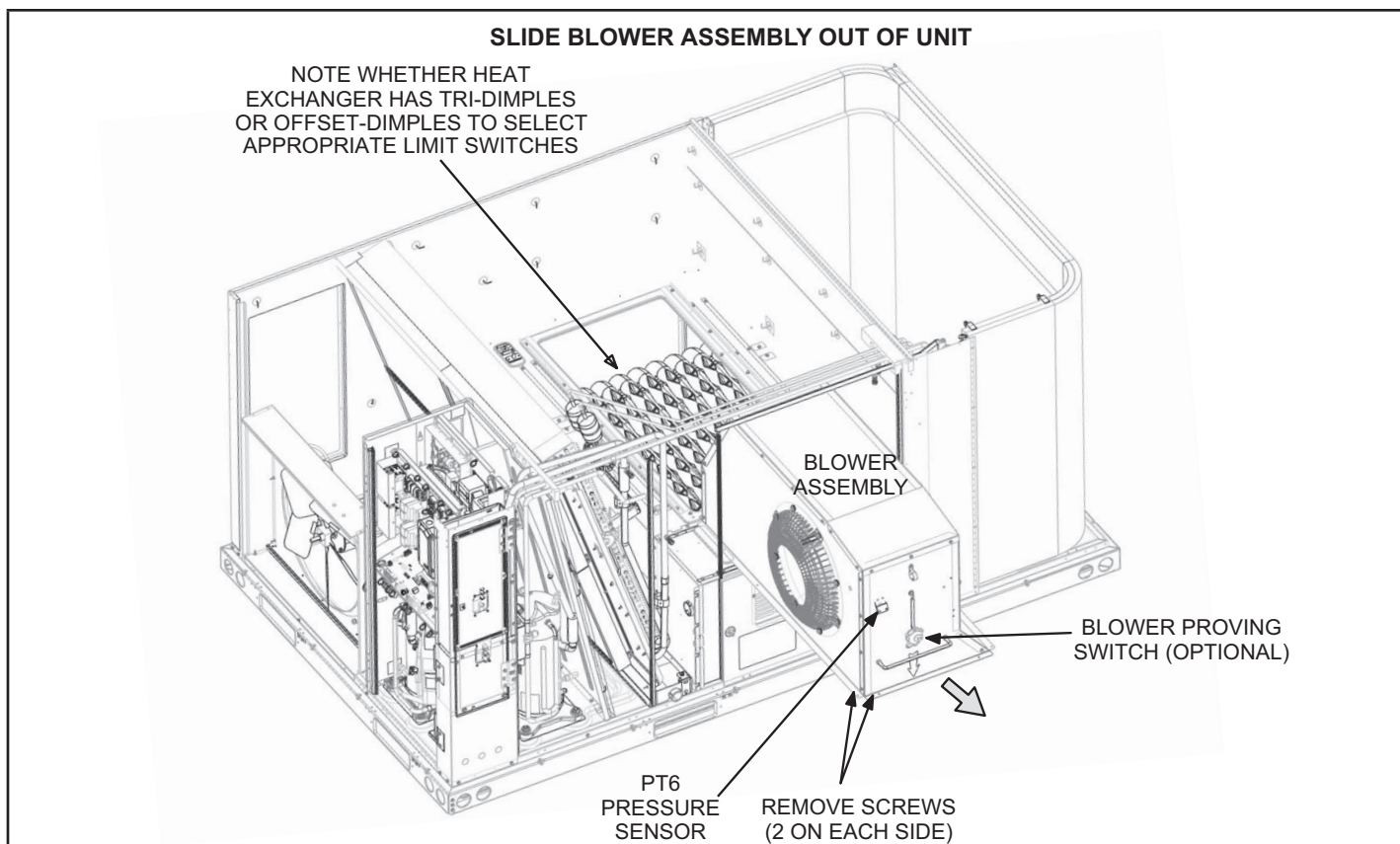

FIGURE 7

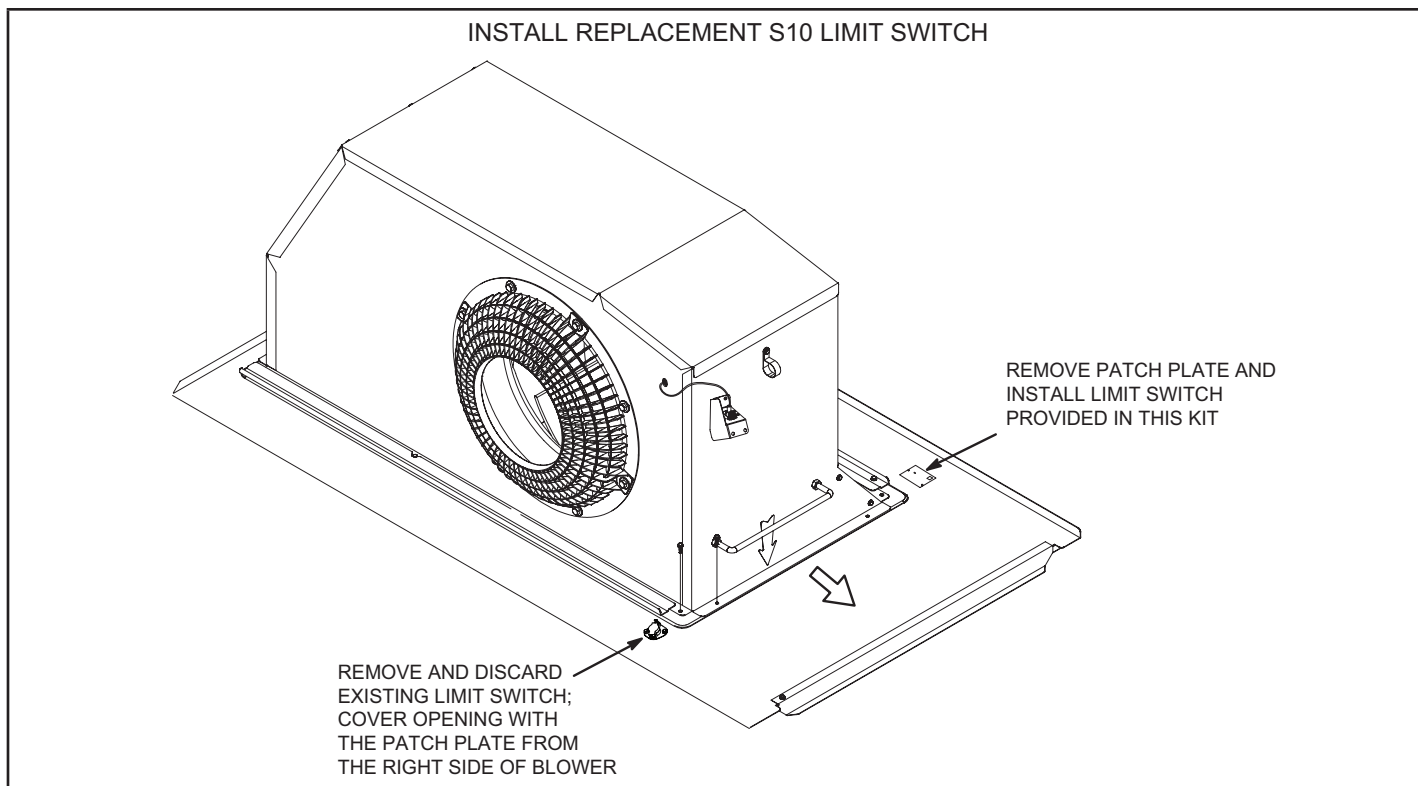

FIGURE 8

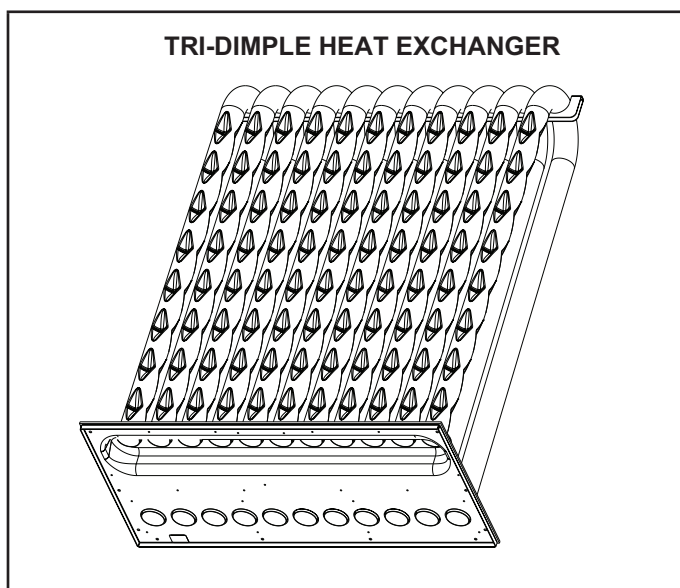

FIGURE 9

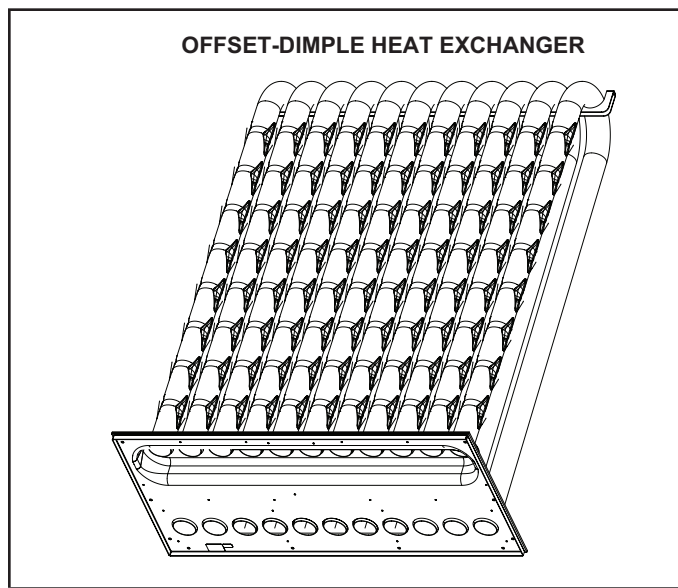

FIGURE 10

Connect Power Wiring

Connect J48 power harness to P48 (previously routed from replacement blower). See FIGURE 4.

Firmware Update

- 1 - Update the Unit Controller firmware to version 09.01.0224 or newer.
- 2 - Set configuration ID 1, (7) System Blower Sub-Type, to "5" - Direct-Plus Blower (MODBUS). Use menu path RTU MENU > SETUP > INSTALL.