

### INSTALLATION INSTRUCTIONS FOR OUTDOOR AIR DAMPERS AND OUTDOOR AIR HOOD USED WITH 156-360 UNITS

#### Shipping and Packing List

Motorized Outdoor Air Damper Package 1 of 1 contains:

- 1- Outdoor air damper (OAD) assembly
- 1- Bag assembly containing:
  - 2- Wiring diagram D sections
  - 1- P160 wiring harness

Outdoor air hood parts (same as 13U05 & 18X88 hood parts except there are NOT two manual damper blades)

Manual Outdoor Air Damper

Package 1 of 1 contains:

- 2- Manual damper blades

Outdoor air hood parts\*

- 1- Hood top
- 1- Bottom filter bracket
- 2- Front filter brackets (3 on 18X88)
- 2- Hood sides
- 2- Filters (4 on 18X88)

Bag assembly containing:

Self drilling screws

\*When outdoor air assembly is factory-installed, outdoor air hood parts are packaged separately and shipped in the filter compartment. See figure 1.

#### **⚠️WARNING**

Improper installation, adjustment, alteration, service or maintenance can cause property damage, personal injury or loss of life. Installation and service must be performed by a licensed professional HVAC installer or equivalent, service agency, or the gas supplier

#### **⚠️CAUTION**

As with any mechanical equipment, contact with sharp sheet metal edges can result in personal injury. Take care while handling this equipment and wear gloves and protective clothing.

#### Application

Optional outdoor air dampers provide fresh outdoor air. See table 1 for usage.

Motorized Dampers:

*Electro-mechanical units (no Unit Controller)-*

The damper opens to a set position when the blower is operating. To operate the damper only during the occupied time period, an optional thermostat or energy management system must be installed that provides an occupied signal to the unit's thermostat connection.

*Units equipped with an A55 Unit Controller-*

The damper opens to a set position when the blower is operating and an occupied signal is provided to the Unit Controller

Manual Damper:

Damper is manually operated; damper position is manually set at installation and remains in that position.

#### Install Motorized Damper

- 1 - Disconnect all power to unit and open filter access panel.
- 2 - If damper is factory-installed, remove six screws securing hood top to access panel. See figure 2. Retain hood top and go to the Outdoor Air Hood section.
- 3 - Remove and retain sheet metal screws securing cover plate to the top rear access panel. Discard cover plate. See figure 3.

TABLE 1

Damper Type	Unit	Part #	Cat. #
Motorized	156-300S	613924-13	22J27
Manual	156-300S	613924-02	13U05
Motorized	242-360	613924-11	18X89
Manual	242-360	613924-12	18X88



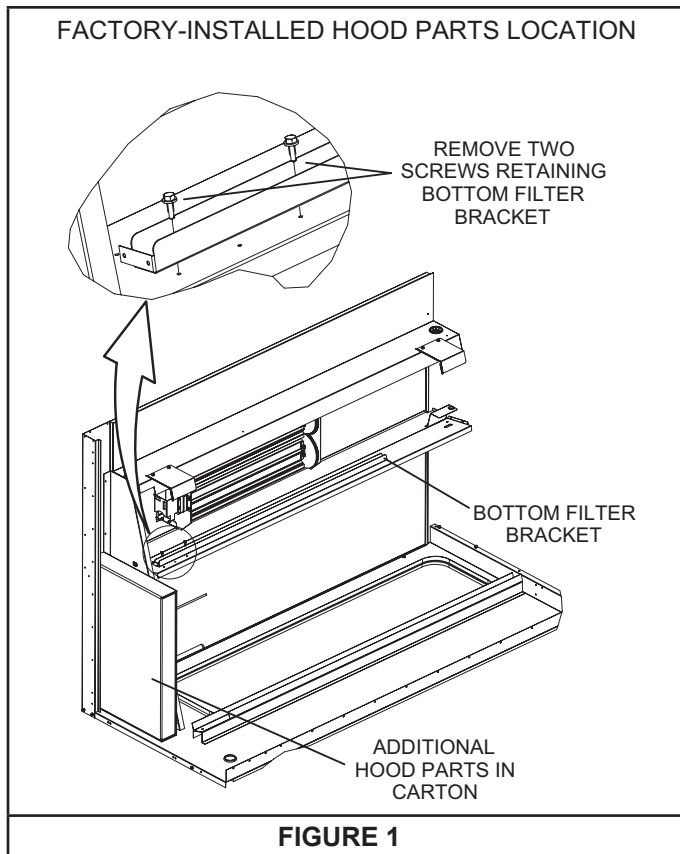

**Install Motorized Damper - Continued**

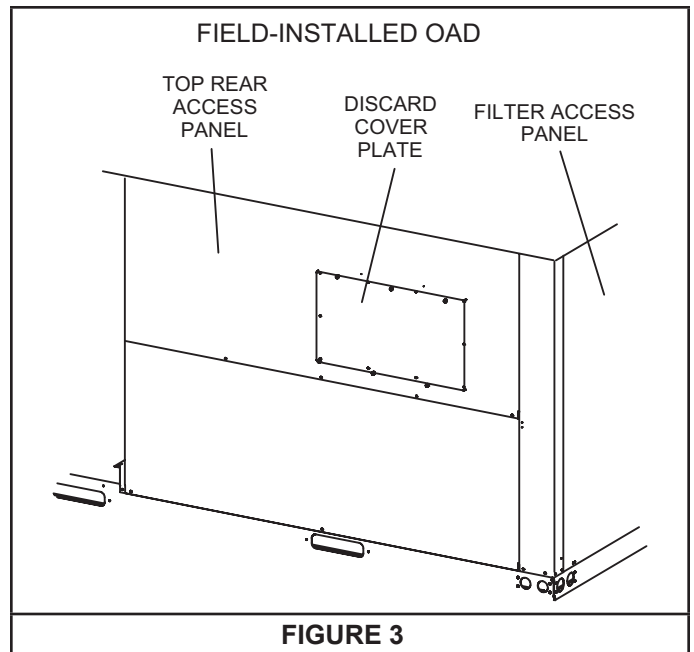
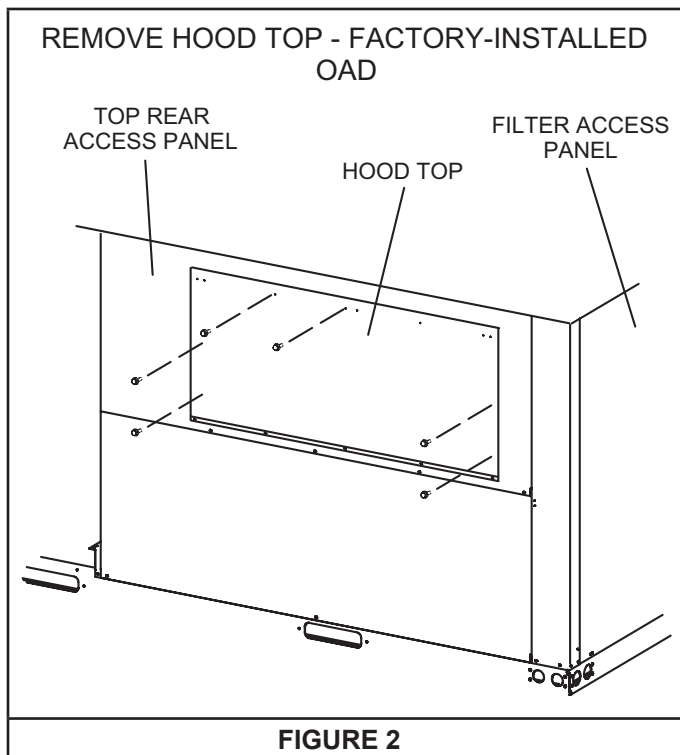

- 1 - Units NOT equipped with an A55 Unit Controller - Open the DIP switch access cover on the damper motor and adjust the setting. See figure 4.
- 2 - Install damper assembly into top rear access opening where the cover plate was secured. See figure 5. Secure with retained screws.
- 3 - From inside the filter access panel, remove the unit jumper plug P3 from unit jack J3 and discard. See figure 6.
- 4 - Units equipped with an A55 Unit Controller - Connect damper motor plug P4 to unit jack J3. Discard P160 jumper harness included in the field kit.
- 5 - Units NOT equipped with an A55 Unit Controller - Connect the kit jumper harness plug P160 to unit jack J3 and jumper jack J160 to the damper motor plug P4. See figure 7.
- 6 - Close the filter access panel.
- 7 - Install the applicable wiring diagram in the control compartment; discard the other diagram. Units equipped with an A55 Unit Controller use the diagram showing A55 in the key list. Units NOT equipped with an A55 Unit Controller use the other diagram.

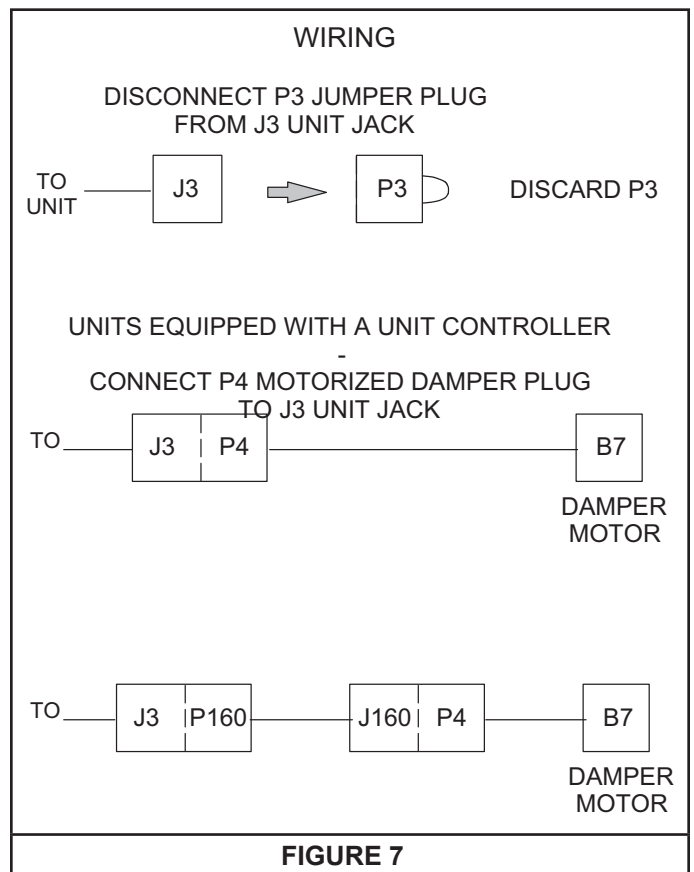
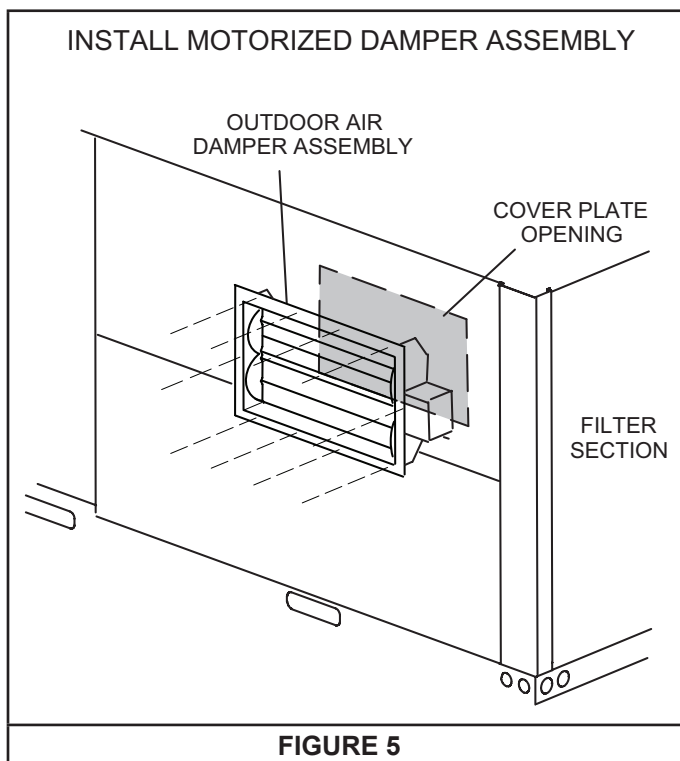
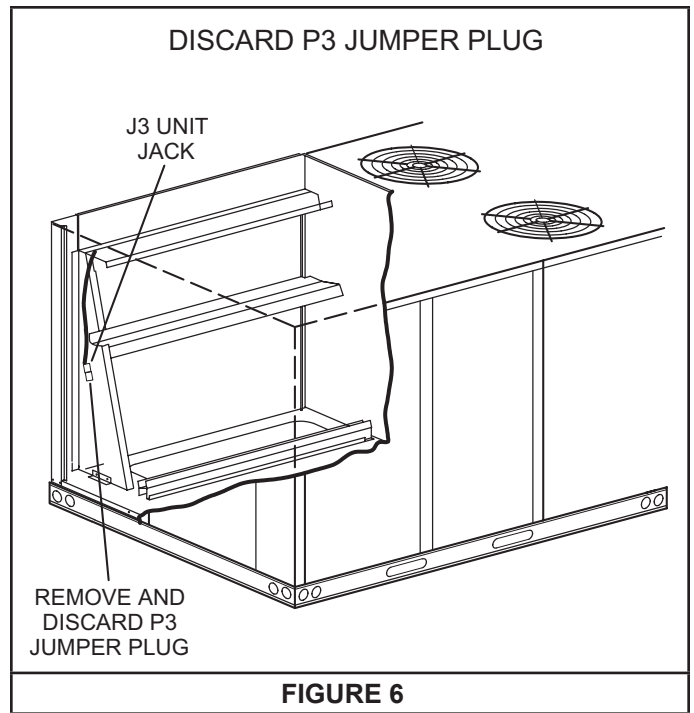
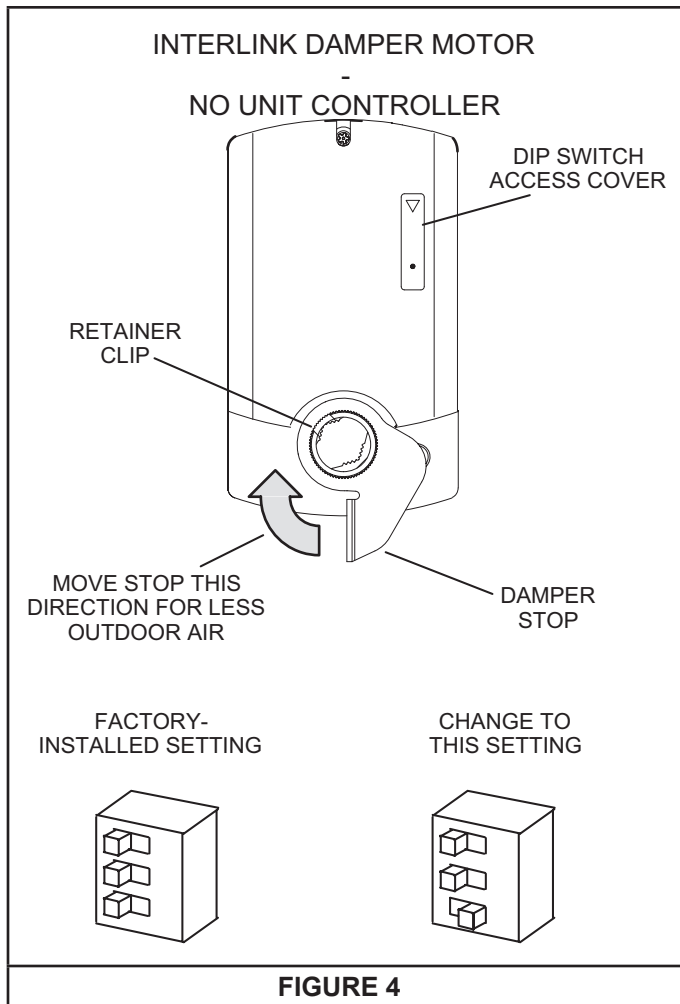

## Install Manual Damper

- 1 - Disconnect all power to unit
- 2 - If manual damper is factory-installed, remove six screws securing hood top to access panel. See figure 2. Retain hood top. Go to step 5.
- 3 - Remove and retain sheet metal screws securing the cover plate to the top rear access panel. Discard cover plate. See figure 3.

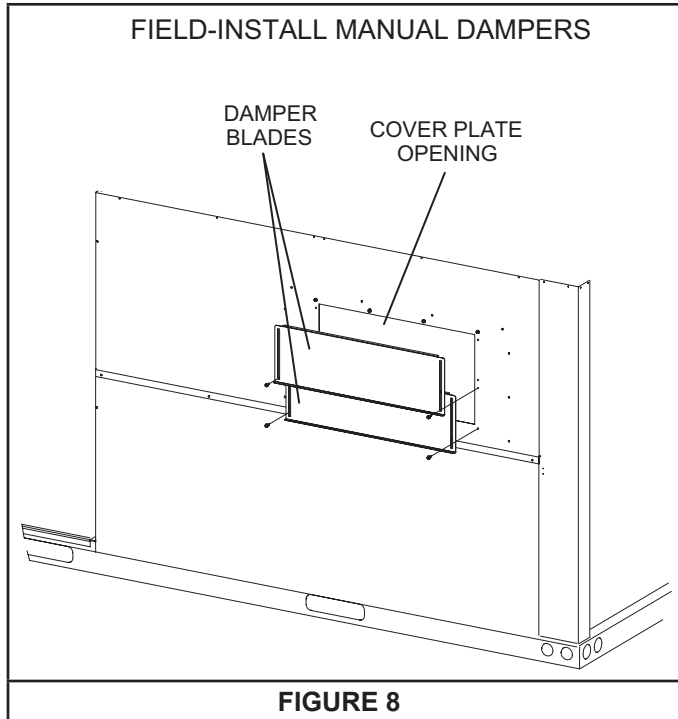

### 4 - Field-Installed Dampers -

Install the two damper blades over the cover plate opening. Secure using four provided screws. See figure 8.

### 5 - Factory-Installed Dampers -

Remove two screws securing dampers in place for shipping. See figure 9.

- 6 - To adjust manual damper outdoor air amount, loosen the slots screws and slide dampers to the desired position. Tighten the screws to secure dampers in place. See figure 9.

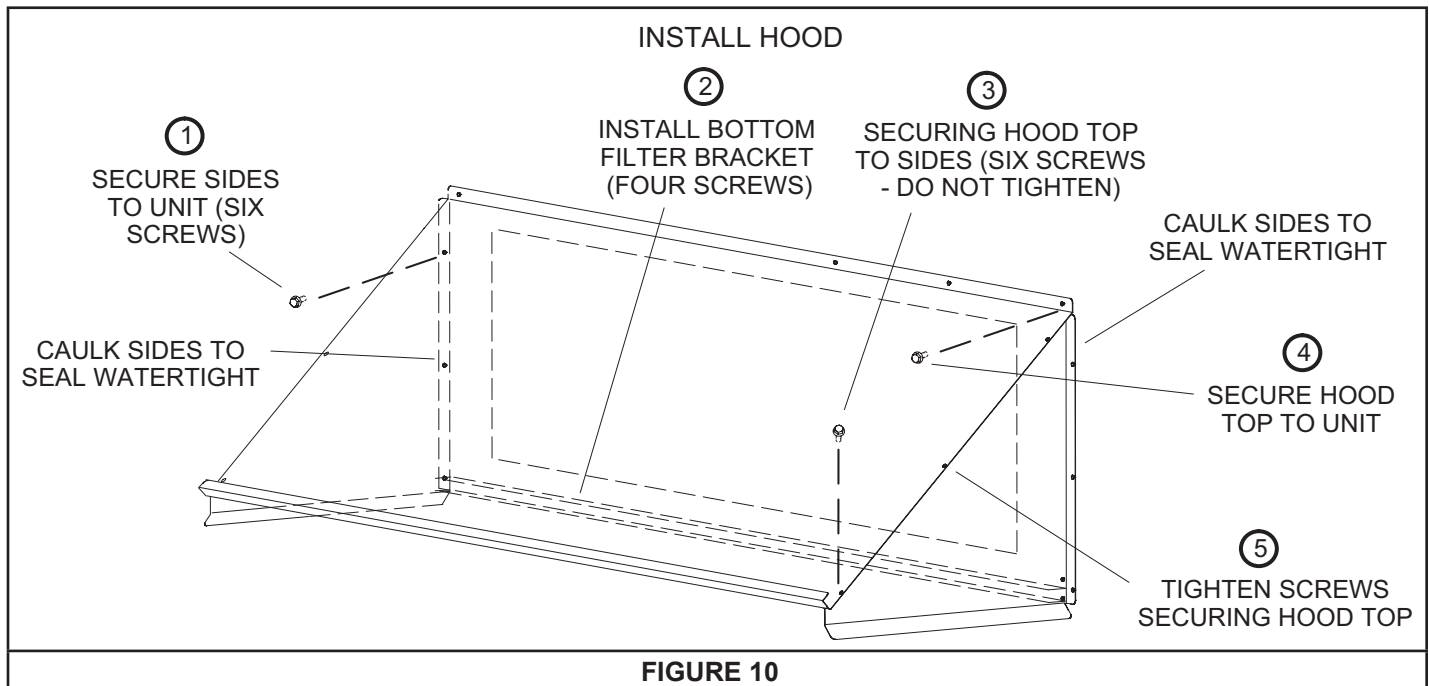
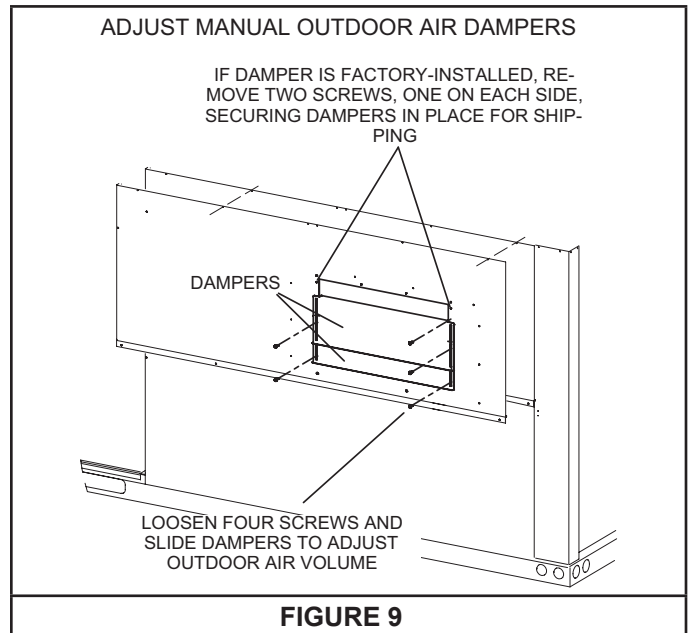

## Outdoor Air Hood

Align dimples to position hood parts and secure in place with #10 self-drilling screws.

- 1 - Use the locating dimples to install the right hood side onto the unit. Install the left side in the same manner. See figure 10.

**NOTE** - Incorrectly positioning the hood sides can result in leaks or a hood that will not assemble properly.

- 2 - Install the bottom filter bracket between the left and right hood sides. Secure in place with #10 screws. See figure 10 and 11.
- 3 - Attach hood top onto the left and right hood sides. Secure with #10 screws.

**IMPORTANT** - Do not tighten screws completely.

- 4 - Align holes in the top flange of the hood top with the locating dimples provided on the unit. Secure with #10 self-drilling screws. See figure 10.
- 5 - Secure the hood top to the left and right hood sides. Tighten the previously-installed screws.

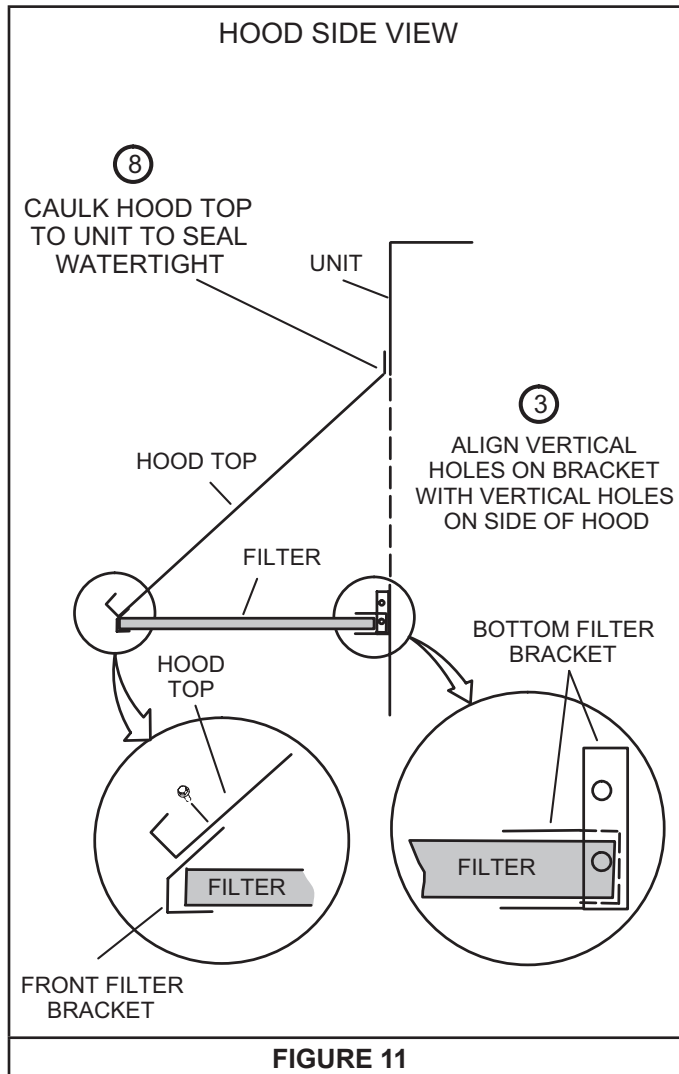

- 6 - Install front filter bracket on the left side of the hood. Secure with three screws. See figure 11 and 12.
- 7 - Insert filter into the bottom filter bracket. Slide filter to the left into the front filter bracket (bracket is shorter on 156-300S units). See figure 12.
- 8 - Insert the remaining filter(s) into the bottom filter bracket. Install the remaining front filter bracket(s) to support the front of filter. Secure using provided screws. See figures 12 and 13.

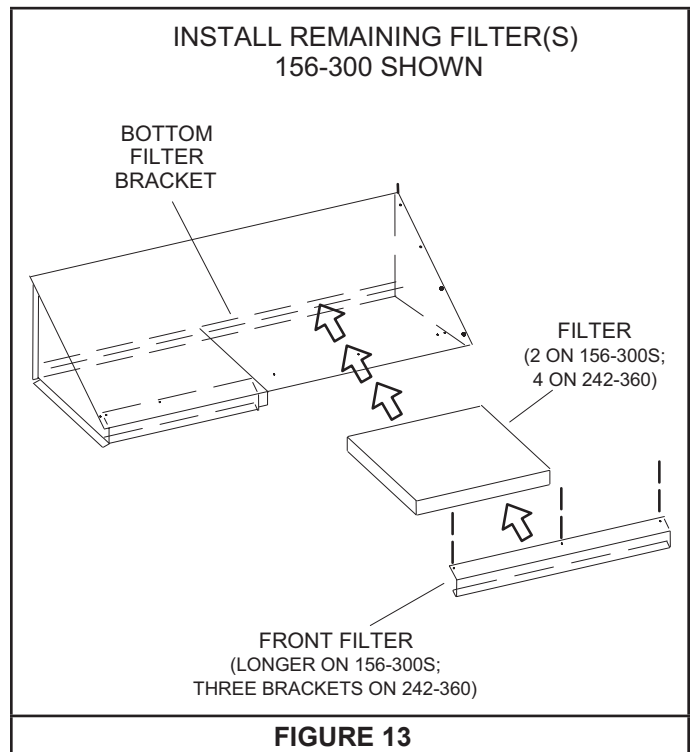
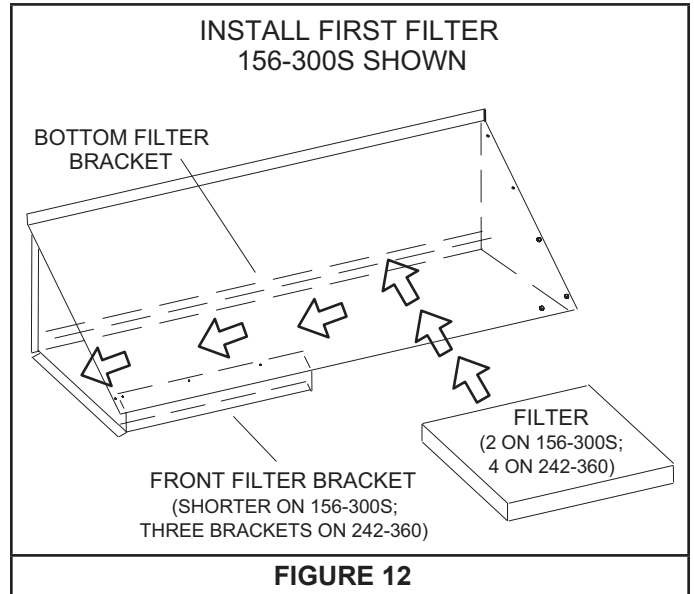

## Determine Outdoor Air Percentage

Outdoor air percentage can be estimated in the same manner for both manual and motorized dampers. Measure outdoor air temperatures according to the following steps and calculate the outdoor air percentage. For motorized dampers, refer to unit specific damper adjustment details following these steps.

- 1 - Measure outdoor air temperature. Mark the point on the bottom line of chart 1 and label the point "A" (40°F, 4°C shown).
- 2 - Measure return air temperature. Mark that point on the top line of chart 1 and label the point "B" (74°F, 23°C shown).
- 3 - Measure mixed air (outdoor and return air) temperature. Mark that point on the top line of chart 1 and label point "C" (70°F, 21°C shown).

- 4 - Draw a straight line between points A and B.
- 5 - Draw a vertical line through point C.
- 6 - Draw a horizontal line where the two lines meet. Read the percent of outdoor air intake on the side.
- 7 - If outdoor air percentage is less or more than desired, increase or decrease minimum damper position. Then, repeat steps 2 through 7 until calculation reads desired outdoor air percentage.

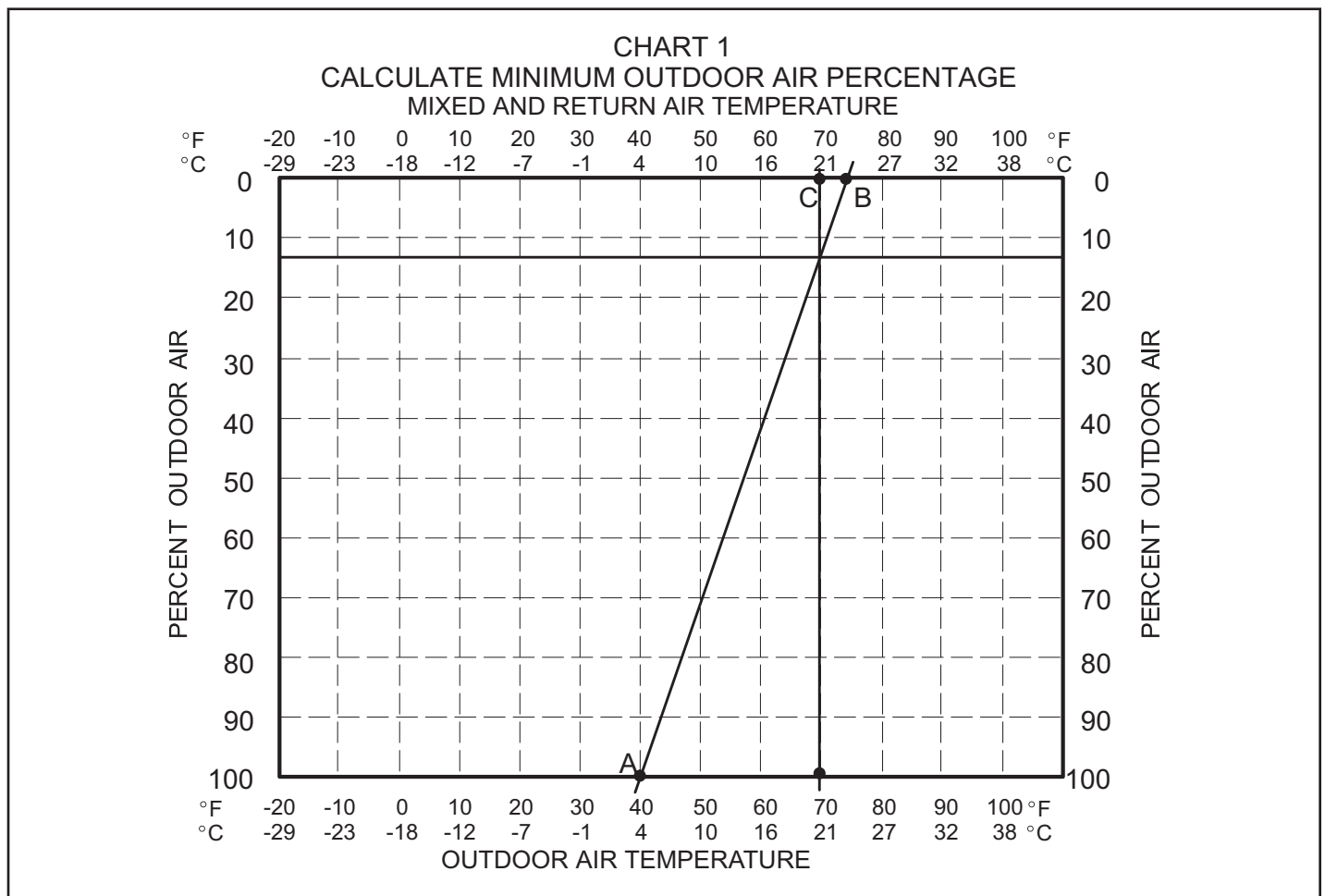

## Damper Minimum Position Adjustments

### Units Equipped With M2 and M3 Unit Controllers

The damper minimum position or positions are adjusted using the Unit Controller input screen. For a unit equipped with more than 1 blower speed, the unit should initially be run on highest speed.

#### 1 - Field-Installed Dampers Only -

Use one of the following menus to enable the motorized damper function on the Unit Controller.

*M3 Unit Controller -*

#### **SETUP > INSTALL**

Navigate through the various screens until CONFIGURATION ID 1 appears. Enable set position 2 to M (motorized outdoor air damper only).

*M2 Unit Controller -*

#### **SETTINGS > INSTALL > NEW M2 > DAMPER > MOAD**

2 - Use one of the following menu paths to set the minimum damper position.

*M3 Unit Controller -*

#### **SETUP > TEST & BALANCE > DAMPER > MIN DAMPER POSITION BLOWER ON HIGH=.%**

*M2 Unit Controller -*

#### **SETTINGS > SETPOINTS > DAMPER > MIN OCP BLOWER HIGH**

3 - Use the Determine Outdoor Air Percentage section to verify the minimum damper air percentage.

#### 4 - Units Equipped With Two Blower Speeds -

Use one of the following menu paths to set the low speed minimum damper position.

*M3 Unit Controller -*

#### **SETUP > TEST & BALANCE > DAMPER > MIN DAMPER POSITION BLOWER ON LOW=.%**

*M2 Unit Controller -*

#### **SETTINGS > SETPOINTS > DAMPER > MIN OCP BLOWER LOW**

5 - Use the Determine Outdoor Air Percentage section to verify the low speed minimum damper air percentage.

**NOTE** - For additional details, refer to Unit Controller manual shipped with unit.

### Units Not Equipped With A Unit Controller

The damper motor stop is preset to provide 100% outdoor air and is adjustable in fixed increments. For units supporting more than 1 blower speed, the damper minimum set point should be determined with the blower operating at the highest speed.

- 1 - To reduce the outdoor air percentage, remove retainer clip and adjust damper stop in the clockwise direction. Replace the retainer clip securing the stop arm in the new position. See figure 4.
- 2 - Power the damper open by providing a blower and occupied demand to the unit thermostat connections.
- 3 - Use the Determine Outdoor Air Percentage section to verify the minimum damper air percentage.
- 4 - Repeat steps 1 through 3 until calculation reads desired outdoor air percentage. Remove the blower and occupied demand signals before adjusting damper stop.
- 5 -



### Minimum Damper Position Range

The motorized outdoor air damper operation is optimized as shown in the shaded area of Chart 2. Unit operation during minimum damper position above this curve increases the potential for rain being drawn into the unit.

- 1 - Remove the metal mesh filter from the hood. Measure the static pressure differential between the return compartment (through filter door is recommended) and outside the unit. Operate the unit with the damper open to minimum position. Record the single blower speed pressure differential in table 2.
- 2 - *Units With More Than One Blower Speed -*  
Repeat the static pressure measurement at each blower speed and minimum set point combination. Record the multiple blower speed pressure differential in table 2.

- 3 - Read the damper percentage open.

*Units Equipped With Unit Controller -*

The damper percentage open was entered into the Unit Controller.

*Units Not Equipped With Unit Controller -*

Operate the unit with the damper open to minimum position. Measure the voltage between pins 7 and 9 from the damper motor plug P4. Calculate the percentage open from the formula:

$$\% \text{ Open} = [(\text{Measure voltage} - 2.5) / 7.0] \times 100$$

- 4 - Plot the damper % open and static pressure drop on Chart 2.
- 5 - Replace the metal mesh filter.
- 6 -

TABLE 2			
Single Blower Speed		Multiple Blower Speed	
Static Pressure Differential - "w.c.	Damper % Open	Static Pressure Differential - "w.c.	Damper % Open

