



ELECTRIC HEAT SECTIONS

507406-02
5/2024
Supersedes 507406-01

EHO075/EHO600 ELECTRIC HEAT

See unit nameplate for manufacturer's name and address.

INSTALLATION INSTRUCTIONS FOR Z1EHO075/600 ELECTRIC HEAT ASSEMBLIES USED WITH ZC 092/150 & ZH 092/120 UNITS

Shipping and Packing List

Package 1 of 1 contains:

- 1- Electric heat assembly 1- Power wiring bundle
- 1- Carton containing: Door assembly
- 1- Bag assembly containing: Screws
- 1- Wiring diagram sticker
- 1- J2 Harness (used on ZC only)

Single Point Power Supply (SPPS) Kit

Package 1 of 1 contains:

IMPORTANT - Single point power supply kit is shipped separately.

- 1- Fuse cover
- 1- Bag assembly containing:
 - 1- Snap bushing
 - 1- Ground lug
 - Screws

- 1- Mounting plate
- 1- Access panel
- 1- Terminal block (TB2)
- 6- Fuses
- 2- Wiring harnesses
- 1- Fuse cover

Inspect packages upon receiving. If damage is found, contact last carrier immediately.

Application

Electric heat sections are used as primary heaters for packaged cooling units and as a secondary heat source for packaged heat pump units. See TABLE 1 for match-ups.

TABLE 1

Unit	Cat. No.	Electric Heat	Volt
ZC 092, 102 ZH 092, 102	30V24/612395-19	7.5 KW	Y Volt
	30V25/612395-20	7.5 KW	G Volt
	30V26/612395-21	7.5 KW	J Volt
ZC 092, 102, 120, 150, ZH 092, 102, 120	30V30/612395-22	15KW	Y Volt
	30V31/612395-23	15KW	G Volt
	30V32/612395-24	15KW	J Volt
ZC 092, 102, 120, 150 ZH 092, 102, 120	30V36/612395-25	22.5 KW	Y Volt
	30V37/612395-26	22.5 KW	G Volt
	30V38/612395-27	22.5 KW	J Volt
ZC 092, 102, 120, 150 ZH 092, 102, 120	30V42/612395-28	30 KW	Y Volt
	30V43/612395-29	30 KW	G Volt
	30V44/612395-30	30 KW	J Volt
ZC 092, 102, 120, 150 ZH 092, 102, 120	30V48/612395-31	45KW	Y Volt
	30V49/612395-32	45KW	G Volt
	30V50/612395-33	45KW	J Volt
ZC 120, 150 ZH 120	30V54/612395-34	60KW	Y Volt
	30V55/612395-35	60KW	G Volt
	30V56/612395-36	60KW	J Volt



Application (cont.)

Single point power supply (SPPS) kits contain two sets of fuses. Refer to the unit nameplate to determine unit maximum overcurrent protection. Install the fuses with a current rating that is no higher than the unit maximum overcurrent protection. See TABLE 2.

TABLE 2
SPPS FUSE SELECTION

Kit	Fuse Amps	Voltage
11M09 / 612394-06	15, 20	575v, 3 ph, 60 hz
11M10 / 612394-07	25, 30	460v, 3 ph, 60 hz 575v, 3 ph, 60 hz
11M11 / 612394-08	35, 40	460v, 3 ph, 60 hz
11M12 / 612394-09	50, 60	230v, 3 ph, 60 hz
11M13 / 612394-10	70, 80	230v, 3 ph, 60 hz

Requirements

The EHO series heaters are ETL design certified.

Installation of electric heaters must conform with standards of the National Fire Protection Association (NFPA) "Standard for Installation of Air Conditioning and Ventilation Systems NFPA No. 90A;" "Standard for the Installation of Residence Type Warm Air Heating and Air Conditioning Systems NFPA No. 90B;" in Canada, CSA C22.1 Canadian Electrical Code — Part I and all applicable CSA requirements; manufacturer's installation instructions and local municipal building codes. Heaters are approved for clearances to combustible materials as listed on heater rating plate.

Accessibility and service clearances must take precedence over fire protection clearances. All wiring must conform with local building codes and the current National Electric Code (NEC) ANSI-C1 and in Canada, CSA C22.1 Canadian Electrical Code —Part I and the applicable CSA requirements.

⚠ WARNING

Improper installation, adjustment, alteration, service or maintenance can cause property damage, personal injury or loss of life. Installation and service must be performed by a licensed professional HVAC installer or equivalent, service agency, or the gas supplier

Install Electric Heat Assembly

- 1 - Disconnect all power to unit.
- 2 - Remove all panels from front of unit. See FIGURE 1.
- 3 - Remove heat access panel. Remove screws and discard rectangular vestibule cover.
- 4 - Locate bundle of three power wires in electric heat kit labeled L1, L2, L3 on both ends. Route power wiring through knockout in bottom left of control panel.
- 5 - Insert electric element heat assembly PARTLY into the unit. Make power wiring connections to TB3 on electric heat assembly. See FIGURE 2. Slide assembly the rest of the way into the unit. Secure assembly using screws provided.

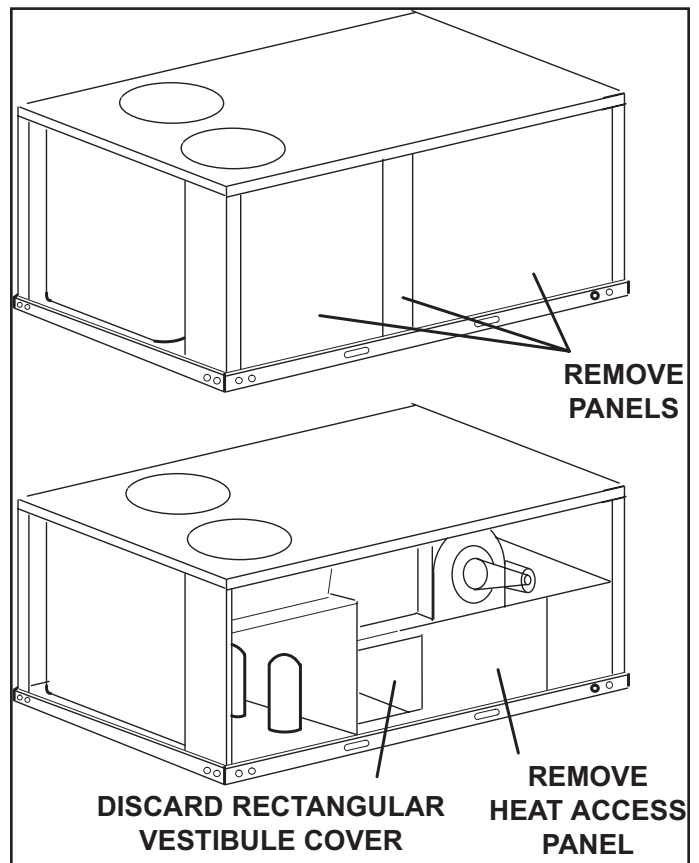

FIGURE 1

⚠ CAUTION

As with any mechanical equipment, contact with sharp sheet metal edges can result in personal injury. Take care while handling this equipment and wear gloves and protective clothing.

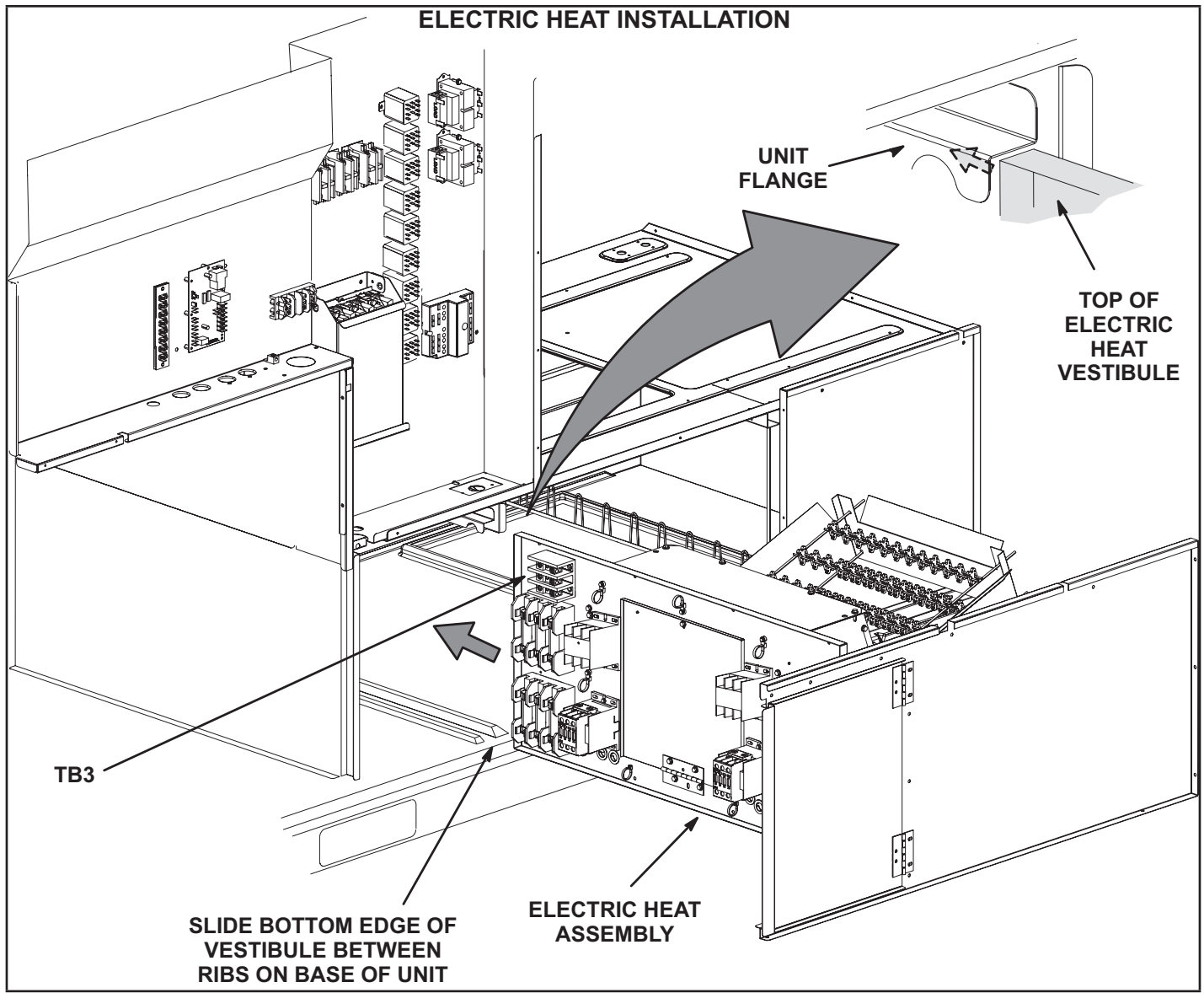

FIGURE 2

6 - Single disconnect installations

Install separately ordered TB2 and F4 fuse block and cover using screws provided. See FIGURE 3 for location.

NOTE - Install electric heat door assembly after electric heat assembly and wiring is complete.

Note: J2 harness is provided in the EH kit. J2 is factory-installed in ZH units so J2 harness can be discarded in ZH installations.

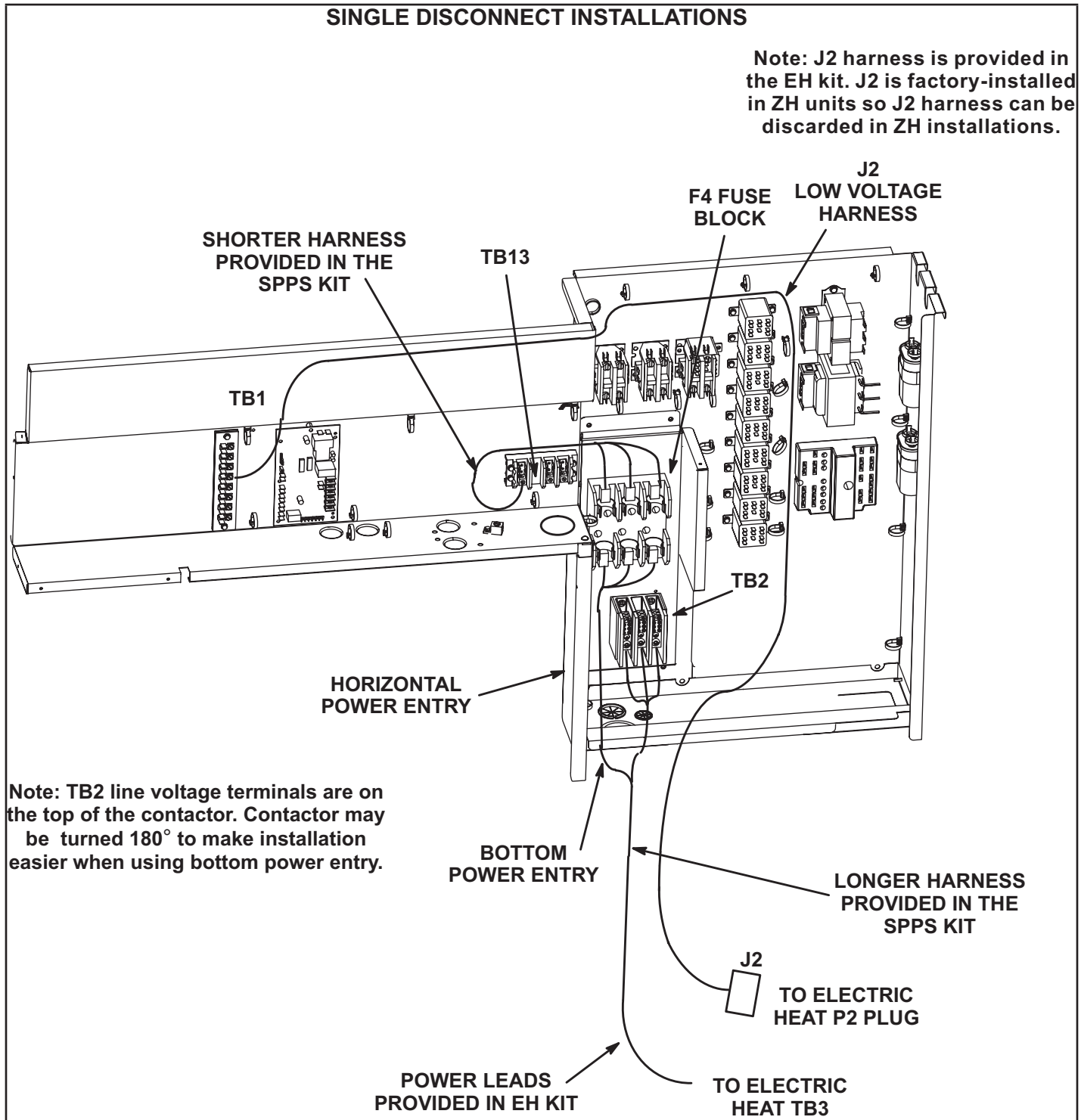

FIGURE 3

Electrical Connections

Wiring must conform to local codes and NEC/CEC. Refer closely to wiring diagram in this instruction and the following information: If electric heat assembly is being installed in an existing unit, a change in power supply wiring and disconnect switch may be required. Remove the original supply wires or disconnect at power source. Refer to heater nameplate for minimum circuit ampacity and maximum fuse size.

- 1 - Review heater installed nameplate for MCA values and enlarge power entry knockouts as needed. Refer to FIGURE 7 for field wiring.
- 2 - Identify harnesses by markings on the end of wires. For wiring between F4 and TB2, use the longer harness provided in the SPPS kit. For wiring between F4 and TB13, use the shorter harness provided in the SPPS kit. For power wiring between TB2 and TB3 (or second power supply wiring to TB3), use the approximately 8-foot harness provided in the electric heat kit. See FIGURE 3 for harness routing.

3 - ZC Units

Locate J2 low voltage harness in the electric heat kit. Connect J2 to P2 electric heat plug. See FIGURE 4. Route wires on other end of harness to the control panel. Use the smaller knockout in the bottom of the control panel.

ZH Units

J2 harness is factory-installed in ZH units. Connect J2 to P2 electric heat plug. See FIGURE 4. Discard J2 harness.

4 - ZC Units

Make J2 harness connections in the control box as shown in FIGURE 5.

- 5 - Select wiring diagram with appropriate voltage and affix to unit in location shown in FIGURE 6.

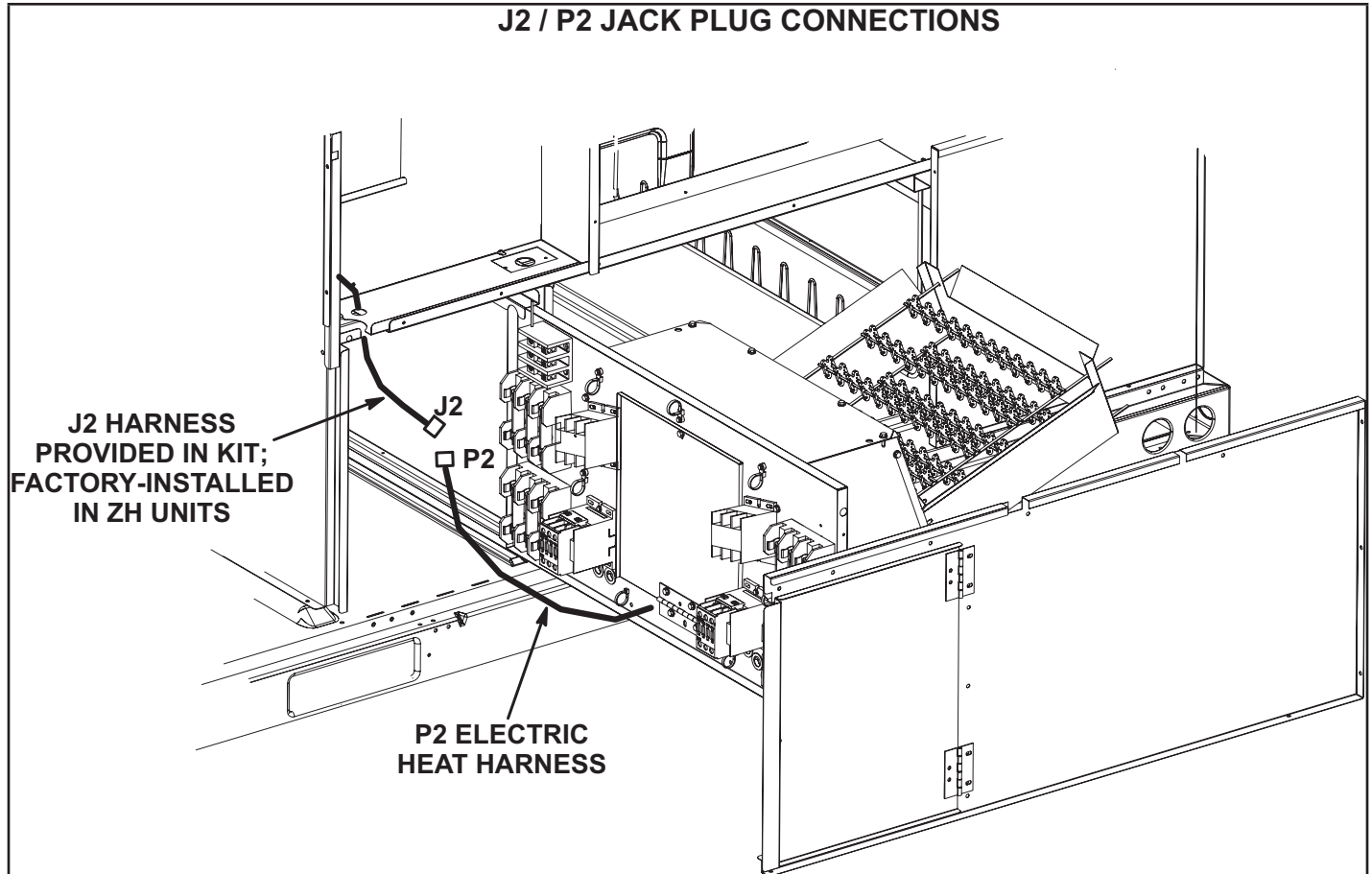

FIGURE 4

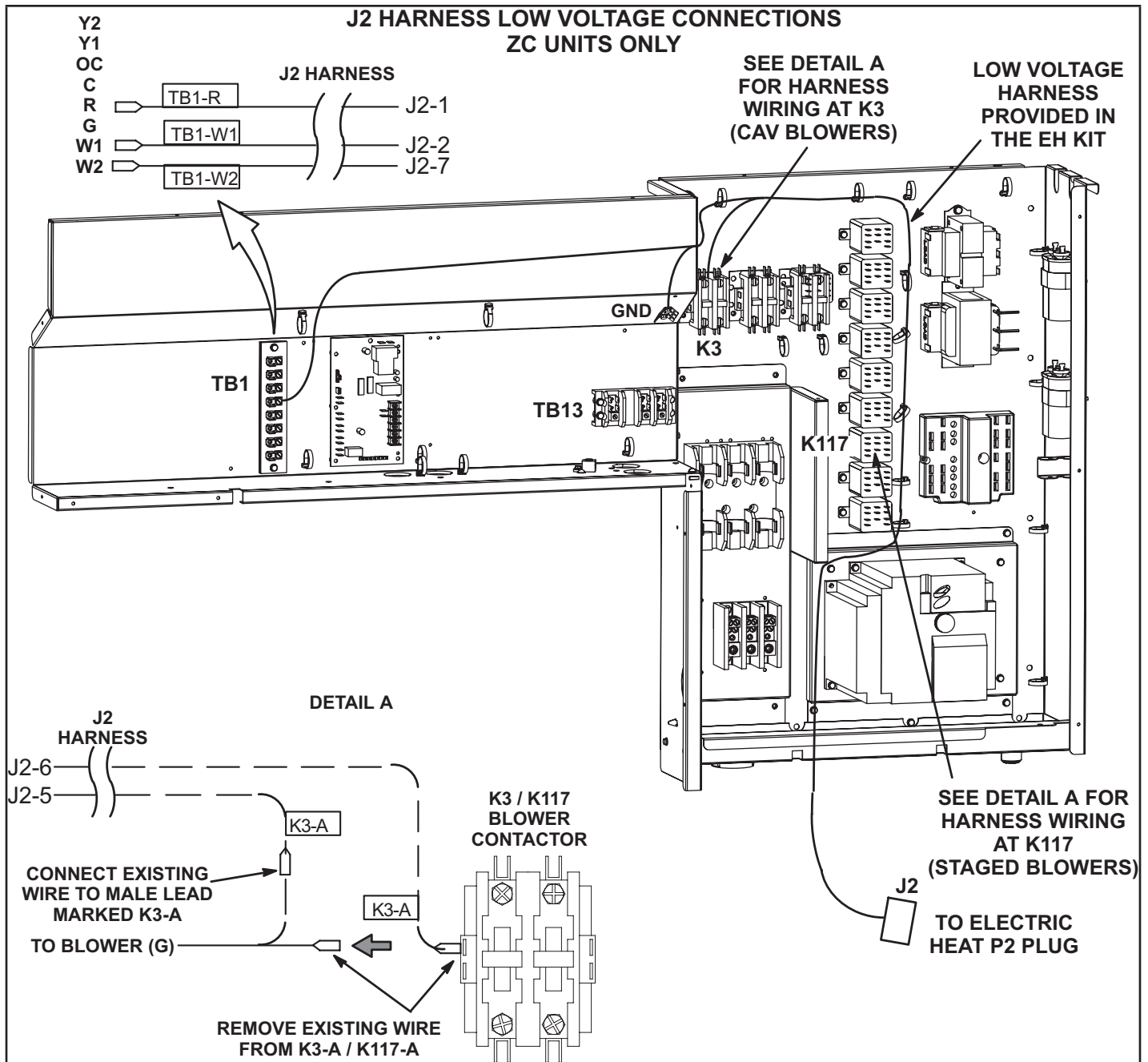

FIGURE 5

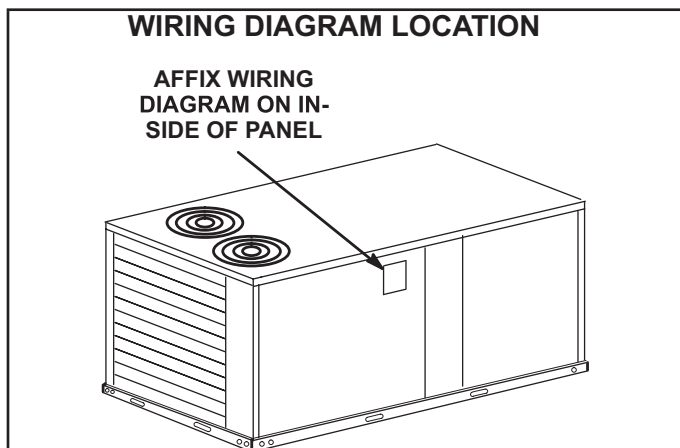

FIGURE 6

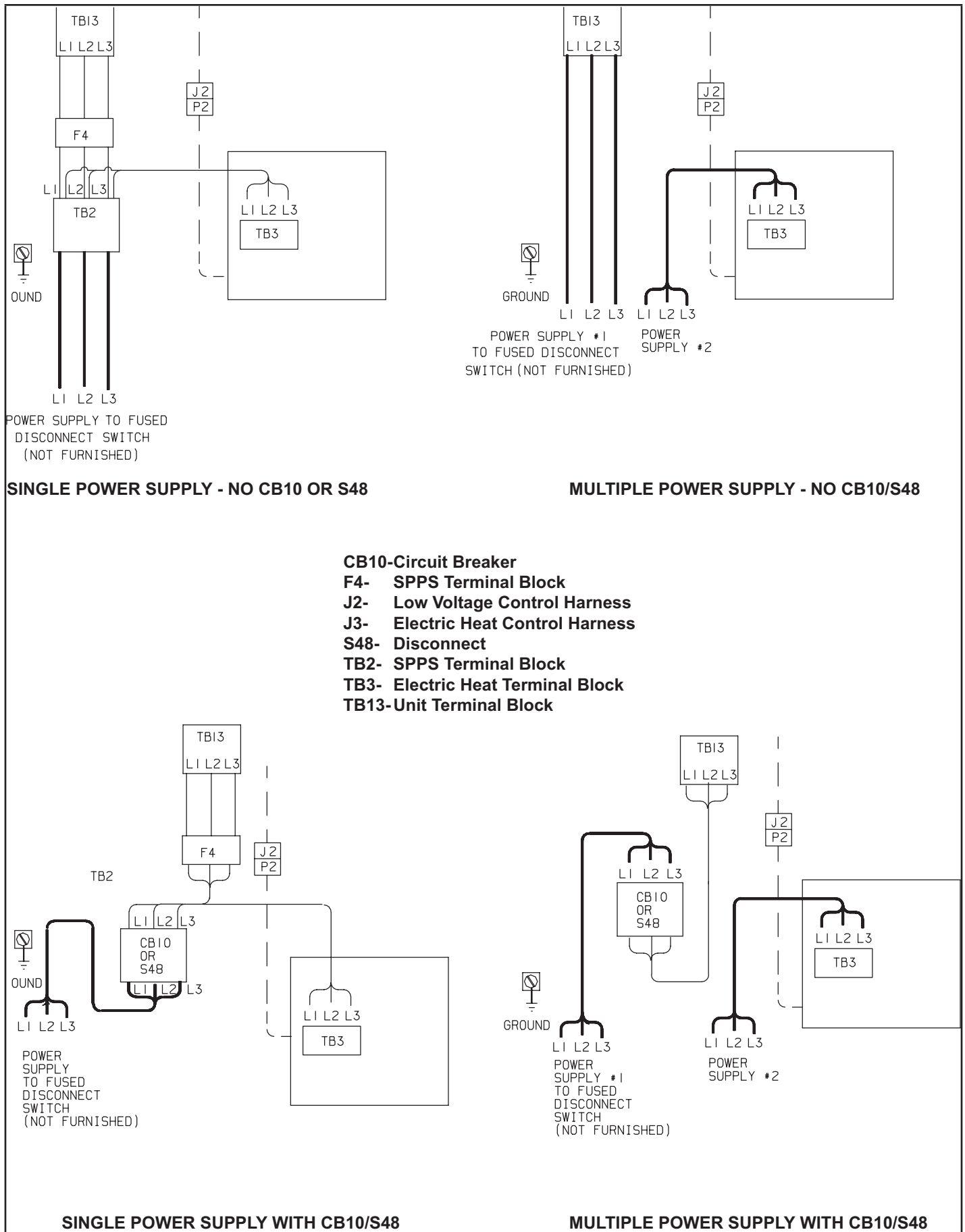

FIGURE 7

Install Door Assembly

Secure heat access panel to electric heat vestibule, blower deck and base of unit. Use existing screws. See FIGURE 8.

Install hinges on electric heat door.

Install knob on electric heat door.

Install spring latch to door frame with #8 screws (provided).

Secure electric heat door hinges onto door frame. Make sure door opens to the right. Make sure door opens and closes properly; adjust hinges if necessary.

Blower Speed Requirements

Electric heater applications require specific supply air blower volumes. Refer to blower tables in the unit installation instruction for start-up.

Unit Start-Up (Heating Cycle)

Set room thermostat for proper heat or auto operation if switching subbase is used. Close disconnect switch and position heat setpoint lever above room temperature. Refer to unit installation instructions for additional information on start-up operations and adjustments.

Heating Operation

Cooling Units:

Single Stage (7.5, 15kW)

A W1 thermostat demand will energize the first stage of electric heat.

Two Stage (22.5, 30, 45, 60kW)

A W1 thermostat demand will energize both stages of electric heat.

Heat Pump Units:

A W1 thermostat demand will energize both compressors in heating mode (reversing valves are not energized). A W2 thermostat demand will energize the first stage of electric heat in addition to compressors operating in heat pump mode.

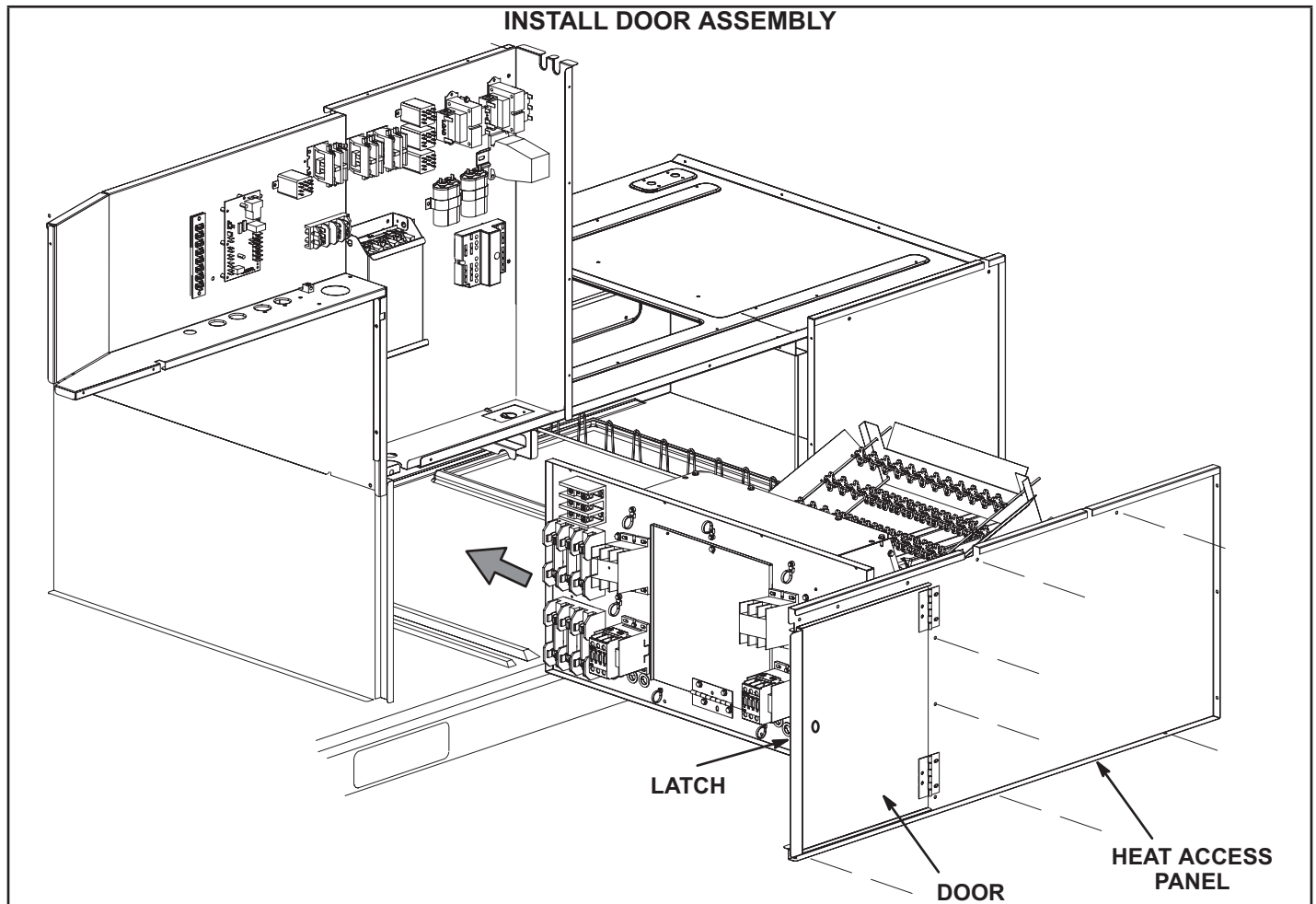

FIGURE 8