

UNIT INFORMATION

KHB

2 / 2.5 / 3 / 4 / 5 / 6 ton

Corp 1815-L6
Revised 09/2022

Service Literature

KHB Standard and High Efficiency Series

The KHB commercial heat pump is available in 2, 2.5, 3, 4, 5 and 6 ton capacities. The KHB024-074 refrigerant systems utilize one compressor, one reversing valve and other parts common to a heat pump. Optional auxiliary electric heat is field installed in KHB units. Electric heat operates in single stage. 5kW through 30kW heat sections are available for the KHB heat pump.

Information contained in this manual is intended for use by qualified service technicians only. All specifications are subject to change. Procedures outlined in this manual are presented as a recommendation only and do not supersede or replace local or state codes.

If the unit must be lifted for service, rig unit by attaching four cables to the holes located in the unit base rail (two holes at each corner). Refer to the installation instructions for the proper rigging technique.

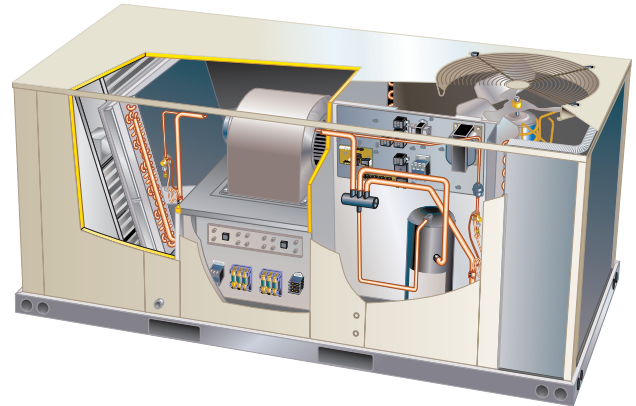

⚠ WARNING

Improper installation, adjustment, alteration, service or maintenance can cause property damage, personal injury or loss of life. Installation and service must be performed by a licensed professional HVAC installer or equivalent, service agency, or the gas supplier.

⚠ WARNING

To prevent serious injury or death:

- 1- Lock-out/tag-out before performing maintenance.
- 2- If system power is required (e.g., smoke detector maintenance), disable power to blower, remove fan belt where applicable, and ensure all controllers and thermostats are set to the "OFF" position before performing maintenance.
- 3- Always keep hands, hair, clothing, jewelry, tools, etc., away from moving parts.

⚠ CAUTION

As with any mechanical equipment, contact with sharp sheet metal edges can result in personal injury. Take care while handling this equipment and wear gloves and protective clothing.

⚠ WARNING



Electric shock hazard. Can cause injury or death. Before attempting to perform any service or maintenance, turn the electrical power to unit OFF at disconnect switch(es). Unit may have multiple power supplies.

Table of Contents

Options / Accessories	Page 2
Specifications	Page 6
Blower Data	Page 11
Blower Drive Kits	Page 24
Electrical / Electric Heat Data.	Page 26
Electric Heat Capacities.	Page 39
Unit Parts Arrangement	Page 40
I-Unit Components	Page 41
II-Placement and Installation	Page 53
III-Start Up	Page 53
IV-System Service Checks.	Page 54
V-Maintenance	Page 57
VI-Accessories	Page 58
VII Wiring Diagrams.	Page 63

OPTIONS / ACCESSORIES

Item	Catalog No.	Unit Model No.							
		KHB 024	KHB 030	KHB 036	KHB 048	KHB 060	KHB 074		
COOLING SYSTEM									
Condensate Drain Trap	PVC	22H54	X	X	X	X	X	X	
	Copper	76W27	X	X	X	X	X	X	
Drain Pan Overflow Switch		74W42	X	X	X	X	X	X	
Low Ambient Kit	Standard Efficiency	14D96	X	X	X	X	X	X	
	High Efficiency	15C84	X		X	X	X		
Efficiency	Standard		O	O	O	O	O	O	
	High		O		O	O			
Refrigerant Type		R-410A	O	O	O	O	O	O	
BLOWER - SUPPLY AIR									
Motors	Direct Drive - 0.25 hp (208/230V-1ph)	Factory	¹ O	¹ O					
	Direct Drive - 0.33 hp (208/230V-1ph)	Factory	² O		² O				
	Direct Drive - 0.50 hp (208/230V-1ph, 208/230V-3ph, 460V-3ph, 575V-3ph)	Factory			^{1,2} O	¹ O			
	Direct Drive - 0.75 hp (208/230V-1ph, 208/230V-3ph, 460V-3ph, 575V-3ph)	Factory				² O			
	Direct Drive - 1.0 hp (208/230V-1ph, 208/230V-3ph, 460V-3ph, 575V-3ph)	Factory					² O		
	Belt Drive - 0.75 hp (208/230V-1ph)	Factory			O	O	O		
	Belt Drive - 1.5 hp (208/230V-1ph)	Factory			O	O	O		
	Belt Drive - 1 hp (208/230V, 460V, 575V-3ph)	Factory			O	O	O		
	Belt Drive - 2 hp (208/230V, 460V, 575V-3ph)	Factory			O	O	O		
	Belt Drive - 0.75 hp (208/230V, 460V, 575V-3ph) (2 Speed)	Factory			O	O			
	Belt Drive - 1 hp (208/230V, 460V, 575V-3ph) (2 Speed)	Factory			O		O	O	
	Belt Drive - 2 hp (208/230V, 460V, 575V-3ph) (2 Speed)	Factory				O	O	O	
	Drive Kits See Blower Data Tables for selection	Kit A01 - 673-1010 rpm	Factory			O			
		Kit A02 - 745-1117 rpm	Factory				O		
		Kit A03 - 833-1250 rpm	Factory					O	
Kit A04 - 968-1340 rpm		Factory						O	
Kit A05 - 897-1346 rpm		Factory			O				
Kit A06 - 1071-1429 rpm		Factory				O			
Kit A07 - 1212-1548 rpm		Factory					O		
Kit A08 - 1193-1591 rpm		Factory						O	
CABINET									
Combination Coil/Hail Guards		13R98	X	X	X				
		13T03				X	³ X		
		13T17					⁴ X	X	
Corrosion Protection			O	O	O	O	O	O	
Hinged Access Panels			O	O	O	O	O	O	
CONTROLS									
NOTE - Also see Conventional Thermostat Control Systems on page 10 for Additional Options.									
Smoke Detector - Supply or Return (Power board and one sensor)		21Z11	X	X	X	X	X	X	
Smoke Detector - Supply and Return (Power board and two sensors)		21Z12	X	X	X	X	X	X	
¹ Standard Efficiency Models.									
² High Efficiency Models.									
³ Standard Efficiency 060S models only.									
⁴ High Efficiency 060H models only.									
NOTE - The catalog and model numbers that appear here are for ordering field installed accessories only.									
OX - Field Installed or Configure to Order (factory installed)									
O - Configure to Order (Factory Installed)									
X - Field Installed									

OPTIONS / ACCESSORIES

Item	Catalog No.	Unit Model No.					
		KHB 024	KHB 030	KHB 036	KHB 048	KHB 060	KHB 074
ECONOMIZER							
Standard Economizer (Sensible Control) (Not for Title 24)							
Standard Economizer	23T20	OX	OX	OX	OX	OX	OX
Factory Installed Economizer - Includes Barometric Relief Dampers, Combination Outdoor Air/Exhaust Hood and Harness							
Field Installed Economizer - Barometric Relief Dampers, Combination Outdoor Air/Exhaust Hood and Harness are not furnished and must be ordered separately (see below)							
Barometric Relief Dampers, Combination Hood and Harness for Field Installed Economizer	23B17	X	X	X	X	X	X
Economizer - No Exhaust	Factory	O	O	O	O	O	O
Standard Economizer Controls (Not for Title 24)							
Single Enthalpy Control	21Z09	OX	OX	OX	OX	OX	OX
Differential Enthalpy Control (order 2)	21Z09	X	X	X	X	X	X
High Performance Economizer (Sensible Control) (Approved for California Title 24 Building Standards / AMCA Class 1A Certified)							
High Performance Economizer (Includes Barometric Relief Dampers and Combination Outdoor Air/Exhaust Hood)	23G22	OX	OX	OX	OX	OX	OX
High Performance Economizer - No Exhaust	Factory	O	O	O	O	O	O
High Performance Economizer Controls (Not for Title 24)							
Single Enthalpy Control	23G26	OX	OX	OX	OX	OX	OX
Differential Enthalpy Control (order 2)	23G26	X	X	X	X	X	X
Economizer Accessories							
Horizontal Economizer Conversion Kit	17W45	X	X	X	X	X	X
POWER EXHAUST FAN							
Standard Static	208/230V-1 or 3ph	21Z13		X	X	X	X
<i>NOTE - Field installed Power Exhaust Fan requires "Barometric Relief Dampers for Power Exhaust Kit" for field installation. See below.</i>	460V-3ph	21Z14		X	X	X	X
	575V-3ph	21Z15		X	X	X	X
BAROMETRIC RELIEF							
¹ Barometric Relief Dampers for Power Exhaust Kit		21Z21		X	X	X	X
² Horizontal Barometric Relief Dampers With Exhaust Hood		19F01	X	X	X	X	X
OUTDOOR AIR							
Outdoor Air Dampers - Includes Outdoor Air Hood							
Motorized		15D17	X	X	X	X	X
Manual		15D18	X	X	X	X	X

¹ Required when Economizer is factory installed with field installed Power Exhaust Fan option.

² Required when Economizer is configured for horizontal airflow.

NOTE - The catalog and model numbers that appear here are for ordering field installed accessories only.

OX - Field Installed or Configure to Order (factory installed)

O - Configure to Order (Factory Installed)

X - Field Installed

OPTIONS / ACCESSORIES

Item	Catalog No.	Unit Model No.					
		KHB 024	KHB 030	KHB 036	KHB 048	KHB 060	KHB 074
ELECTRICAL							
Disconnect	See Electrical/Electric Heat Tables for selection	OX	OX	OX	OX	OX	OX
Voltage 60 Hz	208/230V - 1 phase	O	O	O	O	O	
	208/230V - 3 phase			O	O	O	O
	460V - 3 phase			O	O	O	O
	575V - 3 phase			O	O	O	O
GFI Service Outlets	15 amp non-powered, field-wired (208/230V, 460V only)	74M70	OX	OX	OX	OX	OX
	¹ 20 amp non-powered, field-wired (208/230V, 460V, 575V)	67E01	X	X	X	X	X
Weatherproof Cover for GFI		10C89	X	X	X	X	X
ELECTRIC HEAT							
5 kW	208/230V- 1ph	12F06	X	X			
7.5 kW	208/230V-1ph	14W32	X	X	X	X	X
	208/230V-3ph	14W35			X	X	X
	460V-3ph	14W39			X	X	X
	575V-3ph	14W43			X	X	X
10 kW	208/230V-1ph	30W26	X	X			
15 kW	208/230V-1ph	14W33			X	X	X
	208/230V-3ph	14W36			X	X	X
	460V-3ph	14W40			X	X	X
	575V-3ph	14W44			X	X	X
22.5 kW	208/230V-1ph	14W34				X	
	208/230V-3ph	14W37				X	X
	460V-3ph	14W41				X	X
	575V-3ph	14W45				X	X
30 kW	208/230V-3ph	14W38					X
	460V-3ph	14W42					X
	575V-3ph	14W46					X

¹ Canada requires a minimum 20 amp circuit. Select 20 amp, non-powered, field wired GFI.

NOTE - The catalog and model numbers that appear here are for ordering field installed accessories only.

OX - Field Installed or Configure to Order (factory installed)

O - Configure to Order (Factory Installed)

X - Field Installed

OPTIONS / ACCESSORIES

Item	Catalog No.	Unit Model No.					
		KHB 024	KHB 030	KHB 036	KHB 048	KHB 060	KHB 074
INDOOR AIR QUALITY							
Air Filters							
Healthy Climate® High Efficiency Air Filters	MERV 8 (16 x 20 x 2)	54W20	X	X	X		
	MERV 13 (16 x 20 x 2)	52W37	X	X	X		
Order 4 per unit	MERV 16 (16 x 20 x 2)	22H13	X	X	X		
	MERV 8 (20 x 20 x 2)	54W21				X	X
	MERV 13 (20 x 20 x 2)	52W39				X	X
	MERV 16 (20 x 20 x 2)	21U40				X	X
Indoor Air Quality (CO₂) Sensors							
Sensor - Wall-mount, off-white plastic cover with LCD display		77N39	X	X	X	X	X
Sensor - Wall-mount, black plastic case, no display, rated for plenum mounting		87N54	X	X	X	X	X
CO ₂ Sensor Duct Mounting Kit - for downflow applications		85L43	X	X	X	X	X
Aspiration Box - for duct mounting non-plenum rated CO ₂ sensor (77N39)		90N43	X	X	X	X	X
Needlepoint Bipolar Ionization (NPBI)							
Needlepoint Bipolar Ionization Kit		22U14	X	X	X	X	X
UVC Germicidal Lamps							
¹ Healthy Climate® UVC Light Kit (110/230V-1ph)		21A92	X	X	X	X	X
Step-Down Transformers	460V primary, 230V secondary	10H20	X	X	X	X	X
	575V primary, 230V secondary	10H21	X	X	X	X	X
ROOF CURBS							
Hybrid Roof Curbs, Downflow							
8 in. height		11F50	X	X	X	X	² X
14 in. height		11F51	X	X	X	X	² X
18 in. height		11F52	X	X	X	X	² X
24 in. height		11F53	X	X	X	X	² X
Hybrid Roof Curbs, Full Perimeter, Downflow							
8 in. height		11S47					³ X
14 in. height		11S48					³ X
18 in. height		11T01					³ X
24 in. height		11T06					³ X
Adjustable Pitch Curb, Downflow							
14 in. height		43W27	X	X	X	X	² X
CEILING DIFFUSERS							
Step-Down - Order one	RTD9-65S	13K60	X	X	X	X	
	RTD11-95S	13K61					X
Flush - Order one	FD9-65S	13K55	X	X	X	X	
	FD11-95S	13K56					X
Transitions (Supply and Return) - Order one	T1TRAN10AN1	17W53	X	X	X	X	
	T1TRAN20N-1	17W54					X

¹ Lamps operate on 110-230V single-phase power supply. Step-down transformer may be ordered separately for 460V and 575V units. Alternately, 110V power supply may be used to directly power the UVC ballast(s).

² 060H and 074 models will fit smaller roof curbs with overhang. See dimension drawing.

³ 060S models cannot be used on full perimeter curbs.

NOTE - The catalog and model numbers that appear here are for ordering field installed accessories only.

OX - Field Installed or Configure to Order (factory installed)

O - Configure to Order (Factory Installed)

X - Field Installed

SPECIFICATIONS **DIRECT DRIVE BLOWER | STANDARD EFFICIENCY**

General Data		Nominal Tonnage	2 Ton	2.5 Ton	3 Ton	4 Ton
Model No.			KHB024S4D	KHB030S4D	KHB036S4D	KHB048S4D
Efficiency Type			Standard	Standard	Standard	Standard
Blower Type			Multi-Speed Direct Drive	Multi-Speed Direct Drive	Multi-Speed Direct Drive	Multi-Speed Direct Drive
Cooling Performance	Gross Cooling Capacity - Btuh		23,700	29,700	36,300	48,700
	¹ Net Cooling Capacity - Btuh		23,000	28,800	35,000	46,500
	AHRI Rated Air Flow - cfm		820	1000	1200	1620
	² Sound Rating Number (SRN) (dBA)		75	75	75	75
	Total Unit Power - kW		2.0	2.4	3.0	4.2
	¹ SEER (Btuh/Watt)		14.0	14.0	14.0	14.0
	¹ EER (Btuh/Watt)		11.0	11.9	11.5	11.4
Heating Performance	Total High Heating Capacity - Btuh		23,000	30,000	36,600	47,500
	Total Unit Power - kW		1.9	2.4	2.9	3.9
	¹ COP		3.76	3.72	3.64	3.72
	¹ HSPF - Region IV (Region V)		8.00 (6.70)	8.00 (6.70)	8.00 (6.70)	8.00 (6.70)
	Total Low Heating Capacity - Btuh		13,000	16,200	20,400	27,400
	Total Unit Power - kW		1.8	2.2	2.7	3.7
	COP		2.28	2.30	2.32	2.40
Refrigerant	Type		R-410A	R-410A	R-410A	R-410A
	Charge Furnished		12 lbs. 8 oz.	12 lbs. 0 oz.	12 lbs. 0 oz.	14 lbs. 7 oz.
Electric Heating Options - See page 13			5, 7.5, 10 kW	5, 7.5, 10 kW	7.5, 15 kW	7.5, 15 kW
Compressor Type (one per unit)			Scroll	Scroll	Scroll	Scroll
Outdoor Coil	Net face area - sq. ft.		15.6	15.6	15.6	19.3
	Tube diameter - in.		3/8	3/8	3/8	3/8
	Number of rows		2	2	2	2
	Fins / inch		20	20	20	20
Outdoor Coil Fan	Motor - (No.) HP		1/4	1/4	1/4	1/4
	Motor rpm		825	825	825	825
	Total Motor Input - watts		220	230	240	290
	Diameter - (No.) in. / No. of blades		(1) 24 - 3	(1) 24 - 3	(1) 24 - 3	(1) 24 - 3
	Total air volume - cfm		3300	3300	3300	3900
Indoor Coil	Net face area - sq. ft.		7.8	7.8	7.8	9.7
	Tube diameter - in.		3/8	3/8	3/8	3/8
	Number of rows		3	3	3	3
	Fins / inch		14	14	14	14
	Drain Connection (no.) and size - in.		(1) 1 NPT	(1) 1 NPT	(1) 1 NPT	(1) 1 NPT
	Expansion device type		Balanced Port Thermostatic Expansion Valve, removable power head			
Indoor Blower	Nominal Motor HP		0.25	0.25	0.5	0.5
	Wheel nom. diameter x width - in.		(1) 10 x 10	(1) 10 x 10	(1) 10 x 10	(1) 10 x 10
Filters	Type		Disposable			Disposable
	Number and size - in.		(4) 16 x 20 x 2			(4) 20 x 20 x 2
Electrical Characteristics - 60 Hz			208/230V - 1 phase		208/230V 1 phase	208/230V 1 phase
					208/230V, 460V & 575V 3 phase	208/230V, 460V & 575V 3 phase

NOTE - Net capacity includes evaporator blower motor heat deduction. Gross capacity does not include evaporator blower motor heat deduction.

¹AHRI Certified to AHRI Standard 210/240:

Cooling Ratings - 95°F outdoor air temperature and 80°F db/67°F wb entering indoor coil air.

High Temperature Heating Ratings - 47°F db/43°F wb outdoor air temperature and 70°F entering indoor coil air.

Low Temperature Heating Ratings - 17°F db/15°F wb outdoor air temperature and 70°F entering indoor coil air.

² Sound Rating Number (SRN) rated in accordance with test conditions included in ARI Standard 270-95.

SPECIFICATIONS

BELT DRIVE BLOWER | STANDARD EFFICIENCY

General Data		Nominal Tonnage	3 Ton	4 Ton	5 Ton	6 Ton
		Model No.	KHB036S4B	KHB048S4B	KHB060S4B	KHB074S4T
		Efficiency Type	Standard	Standard	Standard	Standard
		Blower Type	Single Speed Belt Drive	Single Speed Belt Drive	Single Speed Belt Drive	Two-Speed Belt Drive
Cooling Performance	Gross Cooling Capacity - Btuh		36,300	48,700	60,600	71,000
	Net Cooling Capacity - Btuh		¹ 35,000	¹ 46,500	¹ 58,000	² 68,000
	AHRI Rated Air Flow - cfm		1200	1620	2020	2100
	³ Sound Rating Number (SRN) (dBA)		75	75	80	83
	Total Unit Power - kW		3.0	4.2	5.0	6.2
	SEER (Btuh/Watt)		¹ 14.0	¹ 14.0	¹ 14.0	---
	IEER (Btuh/Watt)		---	---	---	² 14.0
	EER (Btuh/Watt)		¹ 11.55	¹ 11.4	¹ 11.5	² 11.0
Heating Performance	Total High Heating Capacity - Btuh		36,600	47,500	58,000	70,000
	Total Unit Power - kW		2.9	3.9	4.5	6.1
	¹ COP		3.64	3.72	3.72	3.30
	HSPF - Region IV (Region V)		8.00 (6.70)	8.00 (6.70)	8.00 (6.70)	---
	Total Low Heating Capacity - Btuh		20,400	27,400	33,000	40,000
	Total Unit Power - kW		2.7	3.7	4.2	5.2
	¹ COP		2.32	2.40	2.38	2.25
Refrigerant	Type		R-410A	R-410A	R-410A	R-410A
	Charge Furnished		12 lbs. 0 oz.	14 lbs. 7 oz.	16 lbs. 0 oz.	24 lbs. 0 oz.
Electric Heating Options - See page 13			7.5, 15 kW	7.5, 15 kW	7.5, 15, 22.5 kW	7.5, 15, 22.5, 30 kW
Compressor Type (one per unit)			Scroll	Scroll	Scroll	Two-Stage Scroll
Outdoor Coil	Net face area - sq. ft.		15.6	19.3	19.3	28.0
	Tube diameter - in.		3/8	3/8	3/8	3/8
	Number of rows		2	2	3	2
	Fins / inch		20	20	20	20
Outdoor Coil Fan	Motor - (No.) HP		(1) 1/4	(1) 1/4	(1) 1/3	(1) 1/2
	Motor rpm		825	825	1075	1075
	Total Motor Input - watts		240	290	405	505
	Diameter - (No.) in. / No. of blades		(1) 24 - 3	(1) 24 - 3	(1) 24 - 3	(1) 24 - 4
	Total air volume - cfm		3300	3900	4300	5735
Indoor Coil	Net face area - sq. ft.		7.8	9.7	9.7	9.7
	Tube diameter - in.		3/8	3/8	3/8	3/8
	Number of rows		3	3	4	4
	Fins / inch		14	14	14	14
	Drain Connection (no.) and size - in.		(1) 1 NPT	(1) 1 NPT	(1) 1 NPT	(1) 1 NPT
	Expansion device type		Balanced Port Thermostatic Expansion Valve, removable power head			
⁴ Indoor Blower & Drive Selection	Nominal Motor	208/230V-1ph	0.75 hp, 1.5 hp	0.75 hp, 1.5 hp	0.75 hp, 1.5 hp	---
	HP	All others voltages	1 hp, 2 hp	1 hp, 2 hp	1 hp, 2 hp	1 hp, 2 hp
	Maximum Usable	208/230V-1ph	0.86 hp, 1.7 hp	0.86 hp, 1.7 hp	0.86 hp, 1.7 hp	---
	Motor HP	All other voltages	1.15 hp, 2.3 hp	1.15 hp, 2.3 hp	1.15 hp, 2.3 hp	1.15 hp, 2.3 hp
	Available Drive Kits		A01	A02	A03	A04
			673 - 1010 rpm	745 - 1117 rpm	833 - 1250 rpm	968 - 1340 rpm
			A05	A06	A07	A08
			897 - 1346 rpm	1071 - 1429 rpm	1212 - 1548 rpm	1193-1591 rpm
	Wheel nominal diameter x width - in.		(1) 10 x 10	(1) 10 x 10	(1) 10 x 10	(1) 10 x 10
Filters	Type		Disposable			
	Number and size - in.		(4) 16 x 20 x 2	(4) 20 x 20 x 2		
Electrical Characteristics - 60 Hz			208/230V 1 phase, 208/230V, 460V & 575V 3 phase	208/230V 1 phase, 208/230V, 460V & 575V 3 phase	208/230V 1 phase, 208/230V, 460V & 575V 3 phase	208/230V, 460V & 575V 3 phase

NOTE - Net capacity includes evaporator blower motor heat deduction. Gross capacity does not include evaporator blower motor heat deduction.

^{1,2} AHRI Certified to AHRI Standard ¹ 210/240 or ² 340/360:

Cooling Ratings - 95°F outdoor air temperature and 80°F db/67°F wb entering indoor coil air.

High Temperature Heating Ratings - 47°F db/43°F wb outdoor air temperature and 70°F entering indoor coil air.

Low Temperature Heating Ratings - 17°F db/15°F wb outdoor air temperature and 70°F entering indoor coil air.

³ Sound Rating Number (SRN) rated in accordance with test conditions included in ARI Standard 270-95.

⁴ Using total air volume and system static pressure requirements determine from blower performance tables rpm and motor hp required. Maximum usable hp of motors furnished are shown. In Canada, nominal motor hp is also maximum usable motor hp. If motors of comparable hp are used, be sure to keep within the service factor limitations outlined on the motor nameplate.

SPECIFICATIONS

DIRECT DRIVE BLOWER | HIGH EFFICIENCY

General Data		Nominal Tonnage	2 Ton	3 Ton	4 Ton	5 Ton
Model No.			KHB024H4E	KHB036H4E	KHB048H4E	KHB060H4E
Efficiency Type			High	High	High	High
Blower Type			Direct Drive-ECM	Direct Drive-ECM	Direct Drive-ECM	Direct Drive-ECM
Cooling Performance	Gross Cooling Capacity - Btuh		23,800	35,700	46,800	59,400
	¹ Net Cooling Capacity - Btuh		23,600	35,200	46,000	58,000
	AHRI Rated Air Flow - cfm		800/560	1200/800	1430/1120	1650/1210
	² Sound Rating Number (SRN) (dBA)		74	75	77	77
	Total Unit Power - kW		1.8	2.8	3.6	4.7
	¹ SEER (Btuh/Watt)		16.5	16.0	16.0	16.0
	¹ EER (Btuh/Watt) - 208/230V		13.0	12.7	12.8	12.5
	¹ EER (Btuh/Watt) - 460V/575V		13.0	12.4	12.8	12.5
Refrigerant	Type		R-410A	R-410A	R-410A	R-410A
	Charge Furnished		13 lbs. 0 oz.	12 lbs. 13 oz.	14 lbs. 0 oz.	20 lbs. 0 oz.
Heating Performance	Total High Heating Capacity - Btuh		24,000	35,000	46,000	59,000
	Total Unit Power - kW		1.8	2.6	3.4	4.7
	¹ COP		3.88	3.90	3.90	3.76
	¹ HSPF - Region IV (Region V)		8.30	8.50	8.50	8.50
	Total Low Heating Capacity - Btuh		13,000	19,200	26,000	34,000
	Total Unit Power - kW		1.6	2.3	3.0	4.0
	COP		2.34	2.40	2.46	2.46
	Electric Heating Options - See page 13			5, 7.5, 10 kW	7.5, 15 kW	7.5, 15 kW
Compressor Type (one per unit)			Two-Stage Scroll	Two-Stage Scroll	Two-Stage Scroll	Two-Stage Scroll
Outdoor Coil	Net face area - sq. ft.		15.6	15.6	19.3	28.0
	Tube diameter - in.		3/8	3/8	3/8	3/8
	Number of rows		2	2	2	2
	Fins / inch		20	20	20	20
Outdoor Coil Fan	Motor - (No.) HP		(1) 1/3	(1) 1/3	(1) 1/3	(1) 1/3
	Motor rpm		725/500	775/650	850/700	930/785
	Total Motor Input - watts		165/60	193/125	251/140	236/145
	Diameter - (No.) in. / No. of blades		24 - 3	24 - 3	24 - 3	24 - 3
	Total air volume - cfm		3340/2240	3500/2970	4060/3330	4135/3385
	Indoor Coil					
Net face area - sq. ft.		7.8	7.8	9.7	9.7	
Tube diameter - in.		3/8	3/8	3/8	3/8	
Number of rows		3	3	3	4	
Fins / inch		14	14	14	14	
Drain Connection (no.) and size - in.		(1) 1 NPT	(1) 1 NPT	(1) 1 NPT	(1) 1 NPT	
Expansion device type		Balanced Port Thermostatic Expansion Valve, removable power head				
Indoor Blower	Nominal Motor HP		0.33	0.5	0.75	1
	Wheel nominal diameter x width - in.		(1) 10 x 10	(1) 10 x 10	(1) 10 x 10	(1) 11 x 10
Filters	Type		Disposable		Disposable	
	Number and size - in.		(4) 16 x 20 x 2		(4) 20 x 20 x 2	
Electrical Characteristics - 60 Hz			208/230V 1 phase	208/230V 1 phase 208/230V, 460V & 575V 3 phase	208/230V 1 phase 208/230V, 460V & 575V 3 phase	208/230V 1 phase 208/230V, 460V & 575V 3 phase

NOTE - Net capacity includes evaporator blower motor heat deduction. Gross capacity does not include evaporator blower motor heat deduction.

¹ AHRI Certified to AHRI Standard 210/240:

Cooling Ratings - 95°F outdoor air temperature and 80°F db/67°F wb entering indoor coil air.

High Temperature Heating Ratings - 47°F db/43°F wb outdoor air temperature and 70°F entering indoor coil air.

Low Temperature Heating Ratings - 17°F db/15°F wb outdoor air temperature and 70°F entering indoor coil air.

² Sound Rating Number (SRN) rated in accordance with test conditions included in ARI Standard 270-95.

SPECIFICATIONS

BELT DRIVE BLOWER | HIGH EFFICIENCY

General Data		Nominal Tonnage	3 Ton	4 Ton	5 Ton	
		Model No.	KHB036H4T	KHB048H4T	KHB060H4T	
		Efficiency Type	High	High	High	
		Blower Type	Two Speed Belt Drive	Two Speed Belt Drive	Two Speed Belt Drive	
Cooling Performance	Gross Cooling Capacity - Btuh		36,200	47,600	59,600	
	¹ Net Cooling Capacity - Btuh		35,000	46,000	57,500	
	AHRI Rated Air Flow - cfm		1200	1600	1800	
	² Sound Rating Number (SRN) (dBA)		75	77	77	
	Total Unit Power - kW		3.0	3.8	4.9	
	¹ SEER (Btuh/Watt) - 208/230V		15.0	15.0	15.0	
	¹ SEER (Btuh/Watt) - 460/575V		14.8	14.8	15.0	
Refrigerant	Type		R-410A	R-410A	R-410A	
	Charge Furnished		12 lbs. 13 oz.	14 lbs. 0 oz.	20 lbs. 0 oz.	
Heating Performance	Total High Heating Capacity - Btuh		35,000	46,000	59,000	
	Total Unit Power - kW		2.8	3.5	4.7	
	¹ COP		3.64	3.82	3.70	
	HSPF - Region IV (Region V)		8.30	8.30	8.30	
	Total Low Heating Capacity - Btuh		19,200	26,000	34,000	
	Total Unit Power - kW		2.3	3.0	4.0	
	¹ COP		2.22	2.38	2.46	
Electric Heating Options - See page 13			7.5, 15 kW	7.5, 15 kW	7.5, 15, 22.5 kW	
Compressor Type (one per unit)			Two-Stage Scroll	Two-Stage Scroll	Two-Stage Scroll	
Outdoor Coil	Net face area - sq. ft.		15.6	19.3	28.0	
	Tube diameter - in.		3/8	3/8	3/8	
	Number of rows		2	2	2	
	Fins / inch		20	20	20	
Outdoor Coil Fan	Motor - (No.) HP		1/3	1/3	1/3	
	Motor rpm		775/650	850/700	930/785	
	Total Motor Input - watts		195/125	251/140	235/145	
	Diameter - (No.) in. / No. of blades		24 - 3	24 - 3	24 - 3	
	Total air volume - cfm		3500/2970	4060/3330	4135/3385	
Indoor Coil	Net face area - sq. ft.		7.8	9.7	9.7	
	Tube diameter - in.		3/8	3/8	3/8	
	Number of rows		3	3	4	
	Fins / inch		14	14	14	
	Drain Connection (no.) and size - in.		(1) 1 NPT	(1) 1 NPT	(1) 1 NPT	
	Expansion device type		Balanced Port Thermostatic Expansion Valve, removable power head			
³ Indoor Blower & Drive Selection	Nominal Motor HP		0.75 hp (low), 1 hp (high)	0.75 hp (low), 2 hp (high)	1 hp (low), 2 hp (high)	
	Maximum Usable Motor HP		0.86 hp (low), 1.15 hp (high)	0.86 hp (low), 2.3 hp (high)	1.15 hp (low), 2.3 hp (high)	
	Available Drive Kits	A01		low 449-673 high 673-1010	A02 low 497-673 high 745-1117	A03 low 555-833 high 833-1250
		A05		low 598-897 high 897-1346	A06 low 714-953 high 1071-1429	A07 low 808-1032 high 1212-1548
		Wheel nominal diameter x width - in.		(1) 10 x 10	(1) 10 x 10	(1) 10 x 10
	Filters	Type		Disposable	Disposable	
		Number and size - in.		(4) 16 x 20 x 2	(4) 20 x 20 x 2	
Electrical Characteristics - 60 Hz			208/230V, 460V & 575V 3 phase	208/230V, 460V & 575V 3 phase	208/230V, 460V & 575V 3 phase	

NOTE - Net capacity includes evaporator blower motor heat deduction. Gross capacity does not include evaporator blower motor heat deduction.

¹AHRI Certified to AHRI Standard 210/240:

Cooling Ratings - 95°F outdoor air temperature and 80°F db/67°F wb entering indoor coil air.

High Temperature Heating Ratings - 47°F db/43°F wb outdoor air temperature and 70°F entering indoor coil air.

Low Temperature Heating Ratings - 17°F db/15°F wb outdoor air temperature and 70°F entering indoor coil air.

² Sound Rating Number (SRN) rated in accordance with test conditions included in ARI Standard 270-95.

³ Using total air volume and system static pressure requirements determine from blower performance tables rpm and motor hp required. Maximum usable hp of motors furnished are shown. In Canada, nominal motor hp is also maximum usable motor hp. If motors of comparable hp are used, be sure to keep within the service factor limitations outlined on the motor nameplate.

BLOWER DATA**DIRECT DRIVE - STANDARD EFFICIENCY - 2 TON | 2.5 TON****BLOWER TABLE INCLUDES RESISTANCE FOR BASE UNIT ONLY WITH DRY INDOOR COIL AND AIR FILTERS IN PLACE.**

FOR ALL UNITS ADD:

1 - Any factory installed options air resistance (economizer, wet coil, etc.) See page 24.

2 - Any field installed accessories air resistance (electric heat, duct resistance, diffuser, etc.) See page 24.

External Static Pressure (in. w.g.)	Air Volume (cfm) at Various Blower Speeds					
	208 VOLTS			230 VOLTS		
	High	Medium	Low	High	Medium	Low
DOWNFLOW	KHB024S4D and KHB030S4D					
0.0	1199	928	838	1379	1085	877
0.1	1229	926	813	1409	1086	872
0.2	1206	928	782	1367	1094	850
0.3	1183	881	742	1350	1047	820
0.4	1159	843	686	1321	1009	783
0.5	1136	812	643	1282	981	762
0.6	1103	766	569	1242	921	705
0.7	1046	728	496	1195	888	625
0.8	953	648	432	1134	792	583
0.9	909	584	335	1037	738	492
1.0	783	465	247	926	592	411
HORIZONTAL	KHB024S4D and KHB030S4D					
0.0	1152	909	801	1325	1063	838
0.1	1152	893	770	1321	1048	826
0.2	1136	866	734	1288	1021	798
0.3	1104	826	697	1260	982	771
0.4	1072	787	643	1222	942	734
0.5	1041	747	589	1175	903	698
0.6	1009	707	534	1137	850	662
0.7	946	654	467	1081	797	588
0.8	861	588	396	1024	718	535
0.9	798	508	319	911	642	468
1.0	715	443	237	846	564	394

BLOWER DATA**DIRECT DRIVE - STANDARD EFFICIENCY - 3 TON****BLOWER TABLE INCLUDES RESISTANCE FOR BASE UNIT ONLY WITH DRY INDOOR COIL AND AIR FILTERS IN PLACE.**

FOR ALL UNITS ADD:

1 - Any factory installed options air resistance (economizer, wet coil, etc.) See page 24.

2 - Any field installed accessories air resistance (electric heat, duct resistance, diffuser, etc.) See page 24.

External Static Pressure (in. w.g.)	Air Volume (cfm) at Various Blower Speeds								
	208 VOLTS			230 VOLTS			460/575 VOLTS		
	High	Medium	Low	High	Medium	Low	High	Medium	Low
DOWNFLOW									
	KHB036S4D								
0.0	1938	1552	1119	2167	1772	1317	2136	1716	1212
0.1	1992	1586	1128	2167	1780	1315	2104	1728	1208
0.2	1915	1592	1137	2100	1792	1307	2052	1684	1197
0.3	1865	1536	1083	2043	1735	1266	1994	1647	1172
0.4	1813	1495	1033	1986	1678	1204	1918	1597	1134
0.5	1762	1444	976	1909	1621	1164	1861	1534	1096
0.6	1694	1391	899	1814	1535	1082	1765	1485	1059
0.7	1609	1331	817	1718	1478	1000	1689	1410	996
0.8	1471	1220	730	1603	1364	918	1613	1335	920
0.9	1368	1066	522	1488	1250	755	1498	1235	848
1.0	1108	869	402	1259	1021	640	1345	1036	763
HORIZONTAL									
	KHB036S4D								
0.0	1862	1520	1070	2082	1736	1259	2085	1745	1247
0.1	1867	1530	1069	2031	1717	1246	2070	1744	1257
0.2	1804	1485	1067	1978	1672	1227	2016	1690	1225
0.3	1741	1440	1018	1907	1627	1190	1944	1643	1192
0.4	1677	1396	968	1837	1567	1128	1890	1596	1160
0.5	1614	1329	894	1749	1492	1066	1800	1533	1111
0.6	1550	1284	844	1660	1417	1016	1727	1455	1062
0.7	1455	1195	769	1554	1327	941	1655	1377	996
0.8	1329	1106	670	1448	1237	842	1511	1283	865
0.9	1202	927	496	1307	1087	718	1403	1190	784
1.0	1012	828	385	1150	973	613	1222	1002	670

BLOWER DATA

DIRECT DRIVE - STANDARD EFFICIENCY - 4 TON

BLOWER TABLE INCLUDES RESISTANCE FOR BASE UNIT ONLY WITH DRY INDOOR COIL AND AIR FILTERS IN PLACE.

FOR ALL UNITS ADD:

1 - Any factory installed options air resistance (economizer, wet coil, etc.) See page 24.

2 - Any field installed accessories air resistance (electric heat, duct resistance, diffuser, etc.) See page 24.

External Static Pressure (in. w.g.)	Air Volume (cfm) at Various Blower Speeds								
	208 VOLTS			230 VOLTS			460/575 VOLTS		
	High	Medium	Low	High	Medium	Low	High	Medium	Low
DOWNFLOW									
	KHB048S4D								
0.0	1951	1542	1098	2139	1542	1271	2139	1542	1271
0.1	1918	1526	1081	2105	1526	1261	2105	1526	1261
0.2	1877	1508	1062	2054	1508	1238	2054	1508	1238
0.3	1814	1448	1026	1986	1448	1196	1986	1448	1196
0.4	1752	1407	990	1918	1407	1154	1918	1407	1154
0.5	1689	1347	936	1826	1347	1099	1826	1347	1099
0.6	1605	1286	864	1735	1286	1043	1735	1286	1043
0.7	1500	1206	774	1644	1206	932	1644	1206	932
0.8	1375	1085	---	1461	1085	---	1461	1085	---
0.9	1202	---	---	---	---	---	---	---	---
1.0	---	---	---	---	---	---	---	---	---
HORIZONTAL									
	KHB048S4D								
0.0	1901	1506	1079	2072	1718	1249	2072	1718	1249
0.1	1855	1478	1069	2026	1686	1238	2026	1686	1238
0.2	1800	1458	1049	1969	1644	1206	1969	1644	1206
0.3	1744	1396	1012	1908	1601	1161	1908	1601	1161
0.4	1687	1346	936	1847	1530	1115	1847	1530	1115
0.5	1630	1296	886	1755	1460	1047	1755	1460	1047
0.6	1546	1222	811	1663	1403	1002	1663	1403	1002
0.7	1461	1147	735	1572	1290	910	1572	1290	910
0.8	1347	1073	660	1419	1205	820	1419	1205	820
0.9	1178	874	560	1296	1006	683	1296	1006	683
1.0	954	624	358	1129	---	496	1129	---	496

BLOWER DATA**DIRECT DRIVE - HIGH EFFICIENCY - 2 TON****BLOWER TABLE INCLUDES RESISTANCE FOR BASE UNIT ONLY WITH DRY INDOOR COIL AND AIR FILTERS IN PLACE.**

FOR ALL UNITS ADD:

1 - Any factory installed options air resistance (economizer, wet coil, etc.) See page 24.

2 - Any field installed accessories air resistance (electric heat, duct resistance, diffuser, etc.) See page 24.

External Static Pressure in. w.g.	Air Volume at Specific Blower Taps (cfm)					
	Tap 1	Tap 2	Tap 3	Tap 4	Tap 5	
DOWNFLOW						KHB024H4E
0.0	635	728	918	1121	1336	
0.1	547	689	861	1071	1290	
0.2	433	607	806	1031	1253	
0.3	371	528	749	986	1212	
0.4	280	460	677	927	1166	
0.5	217	380	605	868	1120	
0.6	---	---	548	819	1071	
0.7	---	---	491	773	1029	
0.8	---	---	442	714	983	
0.9	---	---	393	653	929	
1.0	---	---	---	604	879	
HORIZONTAL						KHB024H4E
0.0	602	715	908	1096	1302	
0.1	509	663	852	1057	1263	
0.2	413	588	793	1007	1227	
0.3	340	507	736	964	1189	
0.4	266	438	679	918	1142	
0.5	220	355	620	864	1100	
0.6	---	---	560	809	1061	
0.7	---	---	500	752	1015	
0.8	---	---	444	706	964	
0.9	---	---	390	661	913	
1.0	---	---	352	612	872	

BLOWER DATA**DIRECT DRIVE - HIGH EFFICIENCY - 3 TON****BLOWER TABLE INCLUDES RESISTANCE FOR BASE UNIT ONLY WITH DRY INDOOR COIL AND AIR FILTERS IN PLACE.**

FOR ALL UNITS ADD:

1 - Any factory installed options air resistance (economizer, wet coil, etc.) See page 24.

2 - Any field installed accessories air resistance (electric heat, duct resistance, diffuser, etc.) See page 24.

External Static Pressure in. w.g.	Air Volume at Specific Blower Taps (cfm)				
	Tap 1	Tap 2	Tap 3	Tap 4	Tap 5
DOWNFLOW	KHB036H4E				
0.0	893	1035	1375	1600	1840
0.1	838	965	1330	1574	1780
0.2	768	895	1277	1543	1748
0.3	705	800	1253	1505	1712
0.4	645	750	1200	1473	1677
0.5	575	690	1150	1435	1638
0.6	---	---	1095	1390	1608
0.7	---	---	1052	1345	1577
0.8	---	---	1004	1302	1528
0.9	---	---	950	1260	1491
1.0	---	---	900	1218	1455
HORIZONTAL	KHB036H4E				
0.0	900	1045	1379	1599	1810
0.1	828	970	1305	1549	1749
0.2	777	900	1264	1504	1718
0.3	702	800	1216	1479	1677
0.4	635	750	1173	1434	1649
0.5	553	685	1131	1399	1622
0.6	---	---	1078	1359	1577
0.7	---	---	1038	1315	1544
0.8	---	---	986	1280	1509
0.9	---	---	933	1236	1471
1.0	---	---	885	1196	1438

BLOWER DATA**DIRECT DRIVE - HIGH EFFICIENCY - 4 TON****BLOWER TABLE INCLUDES RESISTANCE FOR BASE UNIT ONLY WITH DRY INDOOR COIL AND AIR FILTERS IN PLACE.**

FOR ALL UNITS ADD:

1 - Any factory installed options air resistance (economizer, wet coil, etc.) See page 24.

2 - Any field installed accessories air resistance (electric heat, duct resistance, diffuser, etc.) See page 24.

External Static Pressure in. w.g.	Air Volume at Specific Blower Taps (cfm)				
	Tap 1	Tap 2	Tap 3	Tap 4	Tap 5
DOWNFLOW	KHB048H4E				
0.0	1225	1310	1561	2015	2168
0.1	1167	1254	1514	1995	2143
0.2	1112	1203	1473	1977	2126
0.3	1052	1145	1424	1942	2097
0.4	1000	1098	1387	1917	2078
0.5	939	1040	1343	1888	2049
0.6	894	996	1300	1854	2020
0.7	840	941	1250	1819	1991
0.8	780	883	1201	1787	1952
0.9	734	839	1159	1749	1914
1.0	681	784	1115	1704	1856
HORIZONTAL	KHB048H4E				
0.0	1185	1265	1504	1983	2120
0.1	1130	1213	1467	1957	2098
0.2	1085	1171	1432	1932	2077
0.3	1035	1125	1395	1906	2054
0.4	978	1069	1347	1870	2023
0.5	929	1023	1304	1841	1992
0.6	880	977	1267	1811	1962
0.7	822	920	1224	1776	1931
0.8	764	863	1175	1740	1900
0.9	718	820	1133	1710	1869
1.0	549	712	1096	1652	1772

BLOWER DATA**DIRECT DRIVE - HIGH EFFICIENCY - 5 TON****BLOWER TABLE INCLUDES RESISTANCE FOR BASE UNIT ONLY WITH DRY INDOOR COIL AND AIR FILTERS IN PLACE.**

FOR ALL UNITS ADD:

1 - Any factory installed options air resistance (economizer, wet coil, etc.) See page 24.

2 - Any field installed accessories air resistance (electric heat, duct resistance, diffuser, etc.) See page 24.

External Static Pressure in. w.g.	Air Volume at Specific Blower Taps (cfm)				
	Tap 1	Tap 2	Tap 3	Tap 4	Tap 5
DOWNFLOW	KHB060H4E				
0.0	1351	1405	1801	1982	2339
0.1	1303	1359	1769	1956	2310
0.2	1254	1314	1736	1928	2281
0.3	1206	1268	1703	1900	2253
0.4	1158	1222	1669	1870	2224
0.5	1109	1177	1634	1838	2195
0.6	1061	1131	1598	1806	2166
0.7	1012	1085	1561	1772	2137
0.8	964	1040	1524	1736	2108
0.9	915	994	1486	1700	2080
1.0	867	949	1446	1662	2051
HORIZONTAL	KHB60H4E				
0.0	1329	1353	1728	1886	2206
0.1	1284	1320	1708	1872	2189
0.2	1239	1285	1685	1859	2174
0.3	1193	1258	1661	1832	2157
0.4	1147	1218	1636	1814	2135
0.5	1100	1178	1608	1796	2118
0.6	1052	1125	1579	1770	2102
0.7	1004	1085	1548	1743	2080
0.8	955	1044	1516	1716	2058
0.9	906	991	1481	1689	2036
1.0	856	938	1445	1654	2020

BLOWER DATA

BELT DRIVE - 3 TON

BLOWER TABLE INCLUDES RESISTANCE FOR BASE UNIT ONLY WITH DRY INDOOR COIL AND AIR FILTERS IN PLACE.

FOR ALL UNITS ADD:

1 - Any factory installed options air resistance (economizer, wet coil, etc.).

2 - Any field installed accessories air resistance (electric heat, duct resistance, diffuser, etc.).

See page 24 for blower motors and drives and page 24 for wet coil and options/accessory air resistance data.

DOWNFLOW

KHB036S4B - KHB036H4T

Air Volume cfm	External Static - in. w.g.															
	0.10		0.20		0.30		0.40		0.50		0.60		0.70		0.80	
	RPM	BHP	RPM	BHP	RPM	BHP	RPM	BHP	RPM	BHP	RPM	BHP	RPM	BHP	RPM	BHP
700	447	0.09	517	0.12	589	0.15	663	0.17	739	0.19	815	0.20	883	0.23	938	0.25
800	465	0.10	534	0.14	605	0.17	678	0.19	753	0.21	825	0.23	890	0.25	946	0.27
900	486	0.12	554	0.16	623	0.20	695	0.22	767	0.23	836	0.25	897	0.28	953	0.30
1000	508	0.15	576	0.19	643	0.22	713	0.24	783	0.26	848	0.28	907	0.30	961	0.33
1100	533	0.18	599	0.22	665	0.25	733	0.27	800	0.28	863	0.31	919	0.34	971	0.36
1200	560	0.21	625	0.25	689	0.28	755	0.30	820	0.32	879	0.34	932	0.37	983	0.40
1300	591	0.24	654	0.28	716	0.31	779	0.33	841	0.35	897	0.38	948	0.41	996	0.44
1400	631	0.26	690	0.30	748	0.34	807	0.36	864	0.39	916	0.42	964	0.46	1011	0.49
1500	676	0.28	729	0.33	782	0.36	835	0.40	887	0.43	935	0.47	981	0.50	1028	0.54

Air Volume cfm	External Static - in. w.g.															
	0.90		1.00		1.10		1.20		1.30		1.40		1.50		1.60	
	RPM	BHP	RPM	BHP	RPM	BHP	RPM	BHP	RPM	BHP	RPM	BHP	RPM	BHP	RPM	BHP
700	988	0.27	1039	0.29	1088	0.31	---	---	---	---	---	---	---	---	---	---
800	996	0.30	1047	0.32	1098	0.34	1144	0.36	1185	0.39	1224	0.42	---	---	---	---
900	1004	0.33	1055	0.35	1106	0.37	1152	0.40	1193	0.43	1232	0.46	1269	0.49	1305	0.52
1000	1011	0.36	1062	0.38	1111	0.41	1157	0.43	1199	0.47	1238	0.50	1276	0.53	1311	0.56
1100	1020	0.39	1070	0.41	1118	0.44	1163	0.47	1206	0.51	1245	0.54	1282	0.58	1318	0.61
1200	1031	0.43	1079	0.45	1127	0.48	1171	0.52	1213	0.55	1252	0.59	1289	0.62	1324	0.66
1300	1044	0.47	1091	0.49	1137	0.53	1181	0.56	1221	0.60	1259	0.64	1296	0.68	1330	0.71
1400	1058	0.51	1105	0.54	1150	0.57	1191	0.61	1231	0.65	1268	0.69	1303	0.73	1337	0.77
1500	1074	0.56	1120	0.59	1163	0.63	1203	0.67	1241	0.71	1277	0.75	1312	0.79	1345	0.82

BLOWER DATA

BELT DRIVE - 4 TON

BLOWER TABLE INCLUDES RESISTANCE FOR BASE UNIT ONLY WITH DRY INDOOR COIL AND AIR FILTERS IN PLACE.

FOR ALL UNITS ADD:

1 - Any factory installed options air resistance (economizer, wet coil, etc.).

2 - Any field installed accessories air resistance (electric heat, duct resistance, diffuser, etc.).

See page 24 for blower motors and drives and page 24 for wet coil and options/accessory air resistance data.

DOWNFLOW

KHB048S4B - KHB048H4T

Air Volume cfm	External Static - in. w.g.															
	0.10		0.20		0.30		0.40		0.50		0.60		0.70		0.80	
	RPM	BHP	RPM	BHP	RPM	BHP	RPM	BHP	RPM	BHP	RPM	BHP	RPM	BHP	RPM	BHP
900	466	0.10	525	0.14	586	0.17	646	0.20	729	0.20	821	0.19	899	0.20	953	0.23
1000	484	0.12	543	0.16	603	0.19	664	0.22	745	0.23	834	0.23	908	0.24	959	0.26
1100	505	0.15	563	0.18	622	0.22	682	0.25	762	0.26	847	0.26	917	0.27	966	0.30
1200	527	0.18	584	0.21	643	0.25	702	0.28	779	0.30	860	0.30	927	0.31	973	0.34
1300	550	0.21	607	0.25	664	0.29	722	0.32	797	0.33	875	0.34	937	0.35	981	0.38
1400	574	0.25	630	0.29	687	0.32	744	0.35	817	0.37	890	0.38	949	0.39	991	0.42
1500	603	0.28	659	0.32	714	0.36	770	0.39	839	0.41	907	0.42	962	0.44	1002	0.47
1600	651	0.29	703	0.33	754	0.37	806	0.41	867	0.43	927	0.45	976	0.48	1014	0.51
1700	708	0.30	754	0.34	800	0.38	846	0.42	898	0.46	949	0.49	992	0.53	1028	0.57
1800	764	0.31	804	0.36	844	0.40	884	0.45	927	0.49	970	0.54	1008	0.58	1044	0.63
1900	812	0.34	847	0.39	881	0.44	916	0.49	953	0.54	990	0.59	1025	0.64	1061	0.69
2000	857	0.42	889	0.47	920	0.52	952	0.57	986	0.62	1020	0.68	1055	0.73	1091	0.77

Air Volume cfm	External Static - in. w.g.															
	0.90		1.00		1.10		1.20		1.30		1.40		1.50		1.60	
	RPM	BHP	RPM	BHP	RPM	BHP	RPM	BHP	RPM	BHP	RPM	BHP	RPM	BHP	RPM	BHP
900	---	---	---	---	---	---	---	---	---	---	---	---	---	---	---	---
1000	996	0.31	1034	0.35	---	---	---	---	---	---	---	---	---	---	---	---
1100	1001	0.34	1040	0.38	1083	0.42	1128	0.46	1176	0.49	---	---	---	---	---	---
1200	1008	0.38	1047	0.42	1089	0.46	1133	0.49	1180	0.53	1224	0.56	1261	0.60	---	---
1300	1017	0.42	1055	0.46	1097	0.50	1139	0.53	1184	0.57	1228	0.60	1264	0.63	1295	0.67
1400	1026	0.46	1065	0.50	1106	0.54	1147	0.57	1191	0.61	1233	0.64	1269	0.68	1300	0.71
1500	1038	0.51	1076	0.55	1117	0.59	1157	0.62	1199	0.65	1240	0.69	1275	0.72	1305	0.76
1600	1050	0.56	1089	0.60	1129	0.64	1168	0.67	1209	0.71	1249	0.74	1282	0.78	1312	0.82
1700	1065	0.61	1103	0.65	1142	0.69	1181	0.73	1221	0.76	1259	0.80	1292	0.83	1320	0.88
1800	1081	0.67	1118	0.71	1156	0.75	1194	0.79	1234	0.82	1271	0.86	1302	0.90	1330	0.94
1900	1098	0.73	1135	0.77	1172	0.81	1209	0.85	1248	0.88	1284	0.92	1314	0.97	1341	1.01
2000	1128	0.82	1164	0.86	1201	0.89	1239	0.93	1276	0.97	1310	1.01	1336	1.06	1362	1.10

BLOWER DATA

BELT DRIVE - 4 TON

BLOWER TABLE INCLUDES RESISTANCE FOR BASE UNIT ONLY WITH DRY INDOOR COIL AND AIR FILTERS IN PLACE.

FOR ALL UNITS ADD:

1 - Any factory installed options air resistance (economizer, wet coil, etc.).

2 - Any field installed accessories air resistance (electric heat, duct resistance, diffuser, etc.).

See page 24 for blower motors and drives and page 24 for wet coil and options/accessory air resistance data.

HORIZONTAL

KHB048S4B - KHB048H4T

Air Volume cfm	External Static - in. w.g.															
	0.10		0.20		0.30		0.40		0.50		0.60		0.70		0.80	
	RPM	BHP	RPM	BHP	RPM	BHP	RPM	BHP	RPM	BHP	RPM	BHP	RPM	BHP	RPM	BHP
900	464	0.10	514	0.13	576	0.15	644	0.17	728	0.18	817	0.19	893	0.21	951	0.24
1000	482	0.12	533	0.15	595	0.17	662	0.19	744	0.21	829	0.22	902	0.24	957	0.27
1100	504	0.14	556	0.17	617	0.20	683	0.22	762	0.24	843	0.25	912	0.28	965	0.31
1200	528	0.17	581	0.20	641	0.23	706	0.25	782	0.27	859	0.29	924	0.31	974	0.34
1300	556	0.21	609	0.24	669	0.26	731	0.29	804	0.31	877	0.33	938	0.35	985	0.38
1400	592	0.24	645	0.27	702	0.30	763	0.32	830	0.35	898	0.37	953	0.39	997	0.43
1500	641	0.26	692	0.29	746	0.33	801	0.36	862	0.38	921	0.41	970	0.44	1011	0.48
1600	696	0.28	743	0.32	792	0.35	842	0.39	894	0.42	945	0.45	988	0.49	1027	0.53
1700	750	0.31	792	0.35	836	0.39	880	0.43	924	0.47	968	0.51	1007	0.55	1043	0.59
1800	799	0.35	837	0.39	875	0.43	913	0.48	952	0.52	990	0.56	1026	0.61	1061	0.65
1900	840	0.40	873	0.45	907	0.49	941	0.54	976	0.58	1011	0.63	1045	0.67	1080	0.72
2000	883	0.48	913	0.53	944	0.57	976	0.62	1009	0.67	1043	0.71	1078	0.76	1112	0.8

Air Volume cfm	External Static - in. w.g.															
	0.90		1.00		1.10		1.20		1.30		1.40		1.50		1.60	
	RPM	BHP	RPM	BHP	RPM	BHP	RPM	BHP	RPM	BHP	RPM	BHP	RPM	BHP	RPM	BHP
900	995	0.28	1034	0.31	1077	0.35	1121	0.38	---	---	---	---	---	---	---	---
1000	999	0.31	1038	0.34	1081	0.38	1124	0.41	1168	0.44	1211	0.47	---	---	---	---
1100	1006	0.34	1044	0.38	1086	0.41	1129	0.44	1171	0.47	1213	0.50	1253	0.53	1293	0.56
1200	1014	0.38	1052	0.42	1093	0.45	1135	0.48	1176	0.51	1217	0.54	1257	0.58	1296	0.61
1300	1023	0.42	1061	0.46	1102	0.50	1143	0.53	1184	0.56	1224	0.59	1263	0.62	1302	0.66
1400	1035	0.47	1073	0.51	1112	0.54	1153	0.57	1193	0.61	1232	0.64	1271	0.67	1309	0.71
1500	1048	0.52	1086	0.56	1125	0.59	1164	0.63	1204	0.66	1243	0.69	1280	0.73	1317	0.77
1600	1063	0.57	1100	0.61	1139	0.65	1178	0.68	1216	0.71	1254	0.75	1291	0.79	1326	0.83
1700	1079	0.63	1116	0.67	1154	0.71	1192	0.74	1230	0.78	1267	0.81	1302	0.85	1337	0.89
1800	1097	0.69	1133	0.73	1171	0.77	1209	0.80	1246	0.84	1281	0.88	1315	0.92	1349	0.96
1900	1116	0.76	1152	0.80	1189	0.84	1226	0.87	1262	0.91	1296	0.95	1329	0.99	1361	1.03
2000	1148	0.84	1183	0.88	1220	0.92	1257	0.96	1291	1.00	1323	1.04	1354	1.08	1385	1.12

BLOWER DATA

BELT DRIVE - 5 TON

BLOWER TABLE INCLUDES RESISTANCE FOR BASE UNIT ONLY WITH DRY INDOOR COIL AND AIR FILTERS IN PLACE.

FOR ALL UNITS ADD:

1 - Any factory installed options air resistance (economizer, wet coil, etc.).

2 - Any field installed accessories air resistance (electric heat, duct resistance, diffuser, etc.).

See page 24 for blower motors and drives and page 24 for wet coil and options/accessory air resistance data.

DOWNFLOW

KHB060S4B - KHB060H4T

Air Volume cfm	External Static - in. w.g.															
	0.10		0.20		0.30		0.40		0.50		0.60		0.70		0.80	
	RPM	BHP	RPM	BHP	RPM	BHP	RPM	BHP	RPM	BHP	RPM	BHP	RPM	BHP	RPM	BHP
1100	512	0.15	571	0.19	630	0.23	690	0.26	770	0.26	854	0.26	922	0.27	970	0.30
1200	535	0.18	593	0.22	651	0.26	710	0.30	788	0.30	868	0.30	933	0.31	978	0.34
1300	559	0.22	616	0.26	674	0.29	732	0.34	807	0.34	883	0.34	944	0.35	987	0.38
1400	584	0.26	641	0.29	698	0.33	755	0.37	827	0.37	899	0.38	956	0.40	997	0.43
1500	615	0.29	671	0.33	726	0.36	782	0.41	850	0.41	917	0.42	970	0.44	1009	0.47
1600	665	0.30	716	0.34	768	0.38	819	0.44	879	0.44	937	0.46	985	0.49	1022	0.52
1700	723	0.31	768	0.35	814	0.39	860	0.47	910	0.47	959	0.50	1001	0.54	1037	0.58
1800	779	0.32	818	0.37	857	0.41	897	0.50	939	0.50	980	0.55	1018	0.59	1054	0.64
1900	826	0.36	859	0.41	894	0.45	928	0.56	964	0.56	1000	0.61	1036	0.66	1072	0.70
2000	857	0.42	889	0.47	920	0.52	952	0.62	986	0.62	1020	0.68	1055	0.73	1091	0.77
2100	878	0.49	909	0.54	940	0.59	973	0.70	1006	0.70	1041	0.75	1076	0.80	1112	0.85
2200	897	0.55	929	0.61	961	0.66	994	0.78	1028	0.78	1063	0.83	1099	0.89	1134	0.93
2300	918	0.62	950	0.68	983	0.74	1017	0.86	1052	0.86	1087	0.92	1122	0.97	1157	1.02
2400	941	0.70	974	0.77	1008	0.83	1042	0.96	1077	0.96	1111	1.01	1146	1.06	1181	1.11

Air Volume cfm	External Static - in. w.g.															
	0.90		1.00		1.10		1.20		1.30		1.40		1.50		1.60	
	RPM	BHP	RPM	BHP	RPM	BHP	RPM	BHP	RPM	BHP	RPM	BHP	RPM	BHP	RPM	BHP
1100	1006	0.35	1045	0.39	1089	0.43	1134	0.46	---	---	---	---	---	---	---	---
1200	1013	0.38	1053	0.42	1095	0.46	1139	0.50	1186	0.53	1230	0.57	1266	0.60	---	---
1300	1022	0.42	1062	0.46	1104	0.50	1146	0.54	1192	0.57	1234	0.60	1269	0.64	1301	0.68
1400	1033	0.47	1072	0.51	1114	0.55	1155	0.58	1199	0.61	1240	0.65	1275	0.68	1305	0.72
1500	1045	0.52	1085	0.56	1125	0.60	1165	0.63	1208	0.66	1248	0.69	1281	0.73	1311	0.77
1600	1059	0.57	1098	0.61	1138	0.65	1177	0.68	1218	0.71	1257	0.75	1290	0.79	1319	0.83
1700	1074	0.62	1113	0.66	1152	0.70	1190	0.74	1231	0.77	1268	0.80	1299	0.84	1328	0.89
1800	1091	0.68	1129	0.72	1167	0.76	1205	0.80	1244	0.83	1280	0.87	1310	0.91	1338	0.95
1900	1109	0.75	1146	0.79	1183	0.82	1221	0.86	1260	0.90	1294	0.94	1323	0.98	1349	1.02
2000	1128	0.82	1164	0.86	1201	0.89	1239	0.93	1276	0.97	1310	1.01	1336	1.06	1362	1.10
2100	1148	0.89	1185	0.93	1221	0.97	1258	1.01	1294	1.05	1325	1.09	1351	1.14	1376	1.19
2200	1170	0.97	1206	1.01	1242	1.05	1277	1.09	1311	1.14	1341	1.18	1365	1.23	1390	1.28
2300	1193	1.06	1228	1.09	1262	1.14	1295	1.19	1327	1.24	1355	1.29	1380	1.33	1406	1.37
2400	1216	1.15	1250	1.19	1282	1.24	1313	1.30	1343	1.36	1371	1.40	1396	1.44	1423	1.48

BLOWER DATA

BELT DRIVE - 5 TON

BLOWER TABLE INCLUDES RESISTANCE FOR BASE UNIT ONLY WITH DRY INDOOR COIL AND AIR FILTERS IN PLACE.

FOR ALL UNITS ADD:

1 - Any factory installed options air resistance (economizer, wet coil, etc.).

2 - Any field installed accessories air resistance (electric heat, duct resistance, diffuser, etc.).

See page 24 for blower motors and drives and page 24 for wet coil and options/accessory air resistance data.

HORIZONTAL

KHB060S4B - KHB060H4T

Air Volume cfm	External Static - in. w.g.															
	0.10		0.20		0.30		0.40		0.50		0.60		0.70		0.80	
	RPM	BHP	RPM	BHP	RPM	BHP	RPM	BHP	RPM	BHP	RPM	BHP	RPM	BHP	RPM	BHP
1100	509	0.15	562	0.18	624	0.20	691	0.22	771	0.24	852	0.25	919	0.28	970	0.31
1200	535	0.18	589	0.21	650	0.23	715	0.25	792	0.27	869	0.29	932	0.32	980	0.35
1300	564	0.21	618	0.24	678	0.27	741	0.29	815	0.31	887	0.33	946	0.36	991	0.39
1400	604	0.24	657	0.27	715	0.30	775	0.33	842	0.35	908	0.37	962	0.40	1004	0.43
1500	656	0.26	706	0.30	760	0.33	814	0.36	874	0.39	931	0.41	979	0.45	1019	0.48
1600	712	0.29	758	0.32	807	0.36	855	0.39	906	0.43	955	0.46	997	0.50	1035	0.54
1700	766	0.32	808	0.36	850	0.40	892	0.44	936	0.47	978	0.51	1016	0.56	1052	0.60
1800	814	0.36	851	0.40	888	0.44	925	0.49	963	0.53	1000	0.57	1035	0.62	1071	0.66
1900	853	0.41	886	0.46	919	0.50	952	0.55	986	0.60	1021	0.64	1056	0.69	1091	0.73
2000	883	0.48	913	0.53	944	0.57	976	0.62	1009	0.67	1043	0.71	1078	0.76	1112	0.80
2100	906	0.56	936	0.60	967	0.65	999	0.70	1033	0.75	1067	0.79	1101	0.84	1135	0.88
2200	930	0.64	960	0.68	991	0.73	1024	0.78	1058	0.83	1092	0.88	1126	0.92	1160	0.96
2300	954	0.72	985	0.77	1017	0.82	1051	0.87	1085	0.92	1119	0.96	1152	1.00	1186	1.04
2400	981	0.81	1013	0.86	1046	0.91	1079	0.96	1113	1.00	1180	1.05	1180	1.09	1213	1.13

Air Volume cfm	External Static - in. w.g.															
	0.90		1.00		1.10		1.20		1.30		1.40		1.50		1.60	
	RPM	BHP	RPM	BHP	RPM	BHP	RPM	BHP	RPM	BHP	RPM	BHP	RPM	BHP	RPM	BHP
1100	1010	35.00	1049	0.38	1091	0.42	1134	0.45	1176	0.78	1218	0.51	1258	0.54	1297	0.57
1200	1019	0.38	1058	0.42	1099	0.46	1141	0.49	1182	0.52	1223	0.55	1263	0.58	1302	0.61
1300	1030	0.43	1068	0.47	1108	0.50	1149	0.53	1190	0.56	1230	0.59	1270	0.63	1308	0.66
1400	1042	0.47	1080	0.51	1120	0.55	1160	0.58	1200	0.61	1240	0.65	1278	0.68	1315	0.72
1500	1056	0.53	1094	0.57	1133	0.60	1172	0.63	1212	0.67	250	0.70	1288	0.74	1324	0.77
1600	1071	0.58	1109	0.62	1147	0.66	1186	0.69	1225	0.72	1263	0.76	1299	0.80	1334	0.83
1700	1088	0.64	1126	0.68	1164	0.72	1202	0.75	1240	0.78	1276	0.82	1311	0.86	1345	0.90
1800	1107	0.70	1143	0.74	1181	0.78	1219	0.81	1256	0.85	1290	0.89	1324	0.93	1357	0.97
1900	1126	0.77	1163	0.81	1200	0.85	1237	0.88	1273	0.92	1306	0.96	1339	1.00	1371	1.04
2000	1148	0.84	1183	0.88	1220	0.92	1257	0.96	1291	1.00	1323	1.04	1354	1.08	1385	1.12
2100	1170	0.92	1206	0.96	1242	1.00	1277	1.04	1310	1.08	1340	1.13	1370	1.17	1401	1.21
2200	1195	1.00	1230	1.04	1265	1.08	1299	1.13	1330	1.18	1359	1.23	1388	1.27	1418	1.31
2300	1220	1.08	1254	1.13	1288	1.17	1320	1.23	1350	1.28	1378	1.34	1406	1.38	1435	1.42
2400	1245	1.18	1278	1.22	1311	1.28	1341	1.33	1370	1.40	1397	1.45	1425	1.50	1454	1.54

BLOWER DATA

BELT DRIVE - 6 TON

BLOWER TABLE INCLUDES RESISTANCE FOR BASE UNIT ONLY WITH DRY INDOOR COIL AND AIR FILTERS IN PLACE.

FOR ALL UNITS ADD:

1 - Any factory installed options air resistance (economizer, wet coil, etc.).

2 - Any field installed accessories air resistance (electric heat, duct resistance, diffuser, etc.).

See page 24 for blower motors and drives and page 24 for wet coil and options/accessory air resistance data.

DOWNFLOW

KHB074S4T

Air Volume cfm	External Static - in. w.g.															
	0.10		0.20		0.30		0.40		0.50		0.60		0.70		0.80	
	RPM	BHP	RPM	BHP	RPM	BHP	RPM	BHP	RPM	BHP	RPM	BHP	RPM	BHP	RPM	BHP
1900	826	0.36	859	0.41	894	0.45	928	0.50	964	0.56	1000	0.61	1036	0.66	1072	0.70
2000	857	0.42	889	0.47	920	0.52	952	0.57	986	0.62	1020	0.68	1055	0.73	1091	0.77
2100	878	0.49	909	0.54	940	0.59	973	0.64	1006	0.70	1041	0.75	1076	0.80	1112	0.85
2200	897	0.55	929	0.61	961	0.66	994	0.72	1028	0.78	1063	0.83	1099	0.89	1134	0.93
2300	918	0.62	950	0.68	983	0.74	1017	0.80	1052	0.86	1087	0.92	1122	0.97	1157	1.02
2400	941	0.70	974	0.77	1008	0.83	1042	0.90	1077	0.96	1111	1.01	1146	1.06	1181	1.11
2500	966	0.79	1000	0.86	1034	0.93	1068	1.00	1103	1.06	1137	1.11	1171	1.16	1205	1.20
2600	994	0.90	1028	0.97	1062	1.04	1096	1.10	1130	1.16	1164	1.21	1197	1.26	1231	1.30
2700	1023	1.01	1057	1.08	1091	1.15	1125	1.22	1159	1.27	1192	1.32	1225	1.37	1258	1.41
2800	1053	1.13	1088	1.21	1122	1.27	1155	1.33	1188	1.39	1221	1.43	1253	1.48	1286	1.53
2900	1085	1.26	1119	1.33	1153	1.40	1186	1.45	1218	1.51	1250	1.55	1281	1.61	1313	1.66

Air Volume cfm	External Static - in. w.g.															
	0.90		1.00		1.10		1.20		1.30		1.40		1.50		1.60	
	RPM	BHP	RPM	BHP	RPM	BHP	RPM	BHP	RPM	BHP	RPM	BHP	RPM	BHP	RPM	BHP
1900	1109	0.75	1146	0.79	1183	0.82	1221	0.86	1260	0.90	1294	0.94	1323	0.98	1349	1.02
2000	1128	0.82	1164	0.86	1201	0.89	1239	0.93	1276	0.97	1310	1.01	1336	1.06	1362	1.10
2100	1148	0.89	1185	0.93	1221	0.97	1258	1.01	1294	1.05	1325	1.09	1351	1.14	1376	1.19
2200	1170	0.97	1206	1.01	1242	1.05	1277	1.09	1311	1.14	1341	1.18	1365	1.23	1390	1.28
2300	1193	1.06	1228	1.09	1262	1.14	1295	1.19	1327	1.24	1355	1.29	1380	1.33	1406	1.37
2400	1216	1.15	1250	1.19	1282	1.24	1313	1.30	1343	1.36	1371	1.40	1396	1.44	1423	1.48
2500	1240	1.24	1273	1.29	1302	1.36	1331	1.42	1360	1.48	1388	1.52	1414	1.55	1441	1.58
2600	1265	1.34	1296	1.40	1324	1.47	1352	1.54	1381	1.60	1408	1.64	1434	1.67	1460	1.70
2700	1291	1.46	1321	1.52	1347	1.60	1374	1.67	1403	1.72	1429	1.76	1455	1.79	1481	1.82
2800	1317	1.58	1346	1.66	1372	1.74	1399	1.80	1426	1.85	1451	1.89	1477	1.92	1503	1.95
2900	1343	1.72	1371	1.80	1397	1.88	1424	1.95	1450	1.99	1475	2.02	1500	2.05	1526	2.08

BLOWER DATA

BELT DRIVE - 6 TON

BLOWER TABLE INCLUDES RESISTANCE FOR BASE UNIT ONLY WITH DRY INDOOR COIL AND AIR FILTERS IN PLACE.

FOR ALL UNITS ADD:

1 - Any factory installed options air resistance (economizer, wet coil, etc.).

2 - Any field installed accessories air resistance (electric heat, duct resistance, diffuser, etc.).

See page 24 for blower motors and drives and page 24 for wet coil and options/accessory air resistance data.

HORIZONTAL

KHB074S4T

Air Volume cfm	External Static - in. w.g.															
	0.10		0.20		0.30		0.40		0.50		0.60		0.70		0.80	
	RPM	BHP	RPM	BHP	RPM	BHP	RPM	BHP	RPM	BHP	RPM	BHP	RPM	BHP	RPM	BHP
1900	853	0.41	886	0.46	919	0.50	952	0.55	986	0.60	1021	0.64	1056	0.69	1091	0.73
2000	883	0.48	913	0.53	944	0.57	976	0.62	1009	0.67	1043	0.71	1078	0.76	1112	0.80
2100	906	0.56	936	0.60	967	0.65	999	0.70	1033	0.75	1067	0.79	1101	0.84	1135	0.88
2200	930	0.64	960	0.68	991	0.73	1024	0.78	1058	0.83	1092	0.88	1126	0.92	1160	0.96
2300	954	0.72	985	0.77	1017	0.82	1051	0.87	1085	0.92	1119	0.96	1152	1.00	1186	1.04
2400	981	0.81	1013	0.86	1046	0.91	1079	0.96	1113	1.00	1146	1.05	1180	1.09	1213	1.13
2500	1010	0.91	1042	0.96	1075	1.00	1109	1.05	1142	1.09	1175	1.14	1207	1.18	1239	1.23
2600	1040	1.01	1073	1.05	1106	1.10	1139	1.14	1171	1.19	1203	1.23	1235	1.28	1266	1.33
2700	1072	1.10	1104	1.15	1137	1.20	1169	1.24	1201	1.29	1232	1.34	1263	1.40	1293	1.46
2800	1105	1.21	1137	1.25	1168	1.30	1200	1.35	1231	1.40	1261	1.46	1291	1.52	1321	1.59
2900	1138	1.32	1169	1.37	1200	1.42	1231	1.47	1261	1.53	1291	1.60	1321	1.66	1350	1.73

Air Volume cfm	External Static - in. w.g.															
	0.90		1.00		1.10		1.20		1.30		1.40		1.50		1.60	
	RPM	BHP	RPM	BHP	RPM	BHP	RPM	BHP	RPM	BHP	RPM	BHP	RPM	BHP	RPM	BHP
1900	1126	0.77	1163	0.81	1200	0.85	1237	0.88	1273	0.92	1306	0.96	1339	1.00	1371	1.04
2000	1148	0.84	1183	0.88	1220	0.92	1257	0.96	1291	1.00	1323	1.04	1354	1.08	1385	1.12
2100	1170	0.92	1206	0.96	1242	1.00	1277	1.04	1310	1.08	1340	1.13	1371	1.17	1401	1.21
2200	1195	1.00	1230	1.04	1265	1.08	1299	1.13	1330	1.18	1359	1.23	1388	1.27	1418	1.31
2300	1220	1.08	1254	1.13	1288	1.17	1320	1.23	1350	1.28	1378	1.34	1406	1.38	1435	1.42
2400	1245	1.18	1278	1.22	1311	1.28	1341	1.33	1370	1.40	1397	1.45	1425	1.50	1454	1.54
2500	1271	1.28	1303	1.33	1334	1.39	1363	1.45	1391	1.52	1418	1.57	1446	1.62	1474	1.66
2600	1297	1.39	1328	1.45	1357	1.52	1385	1.58	1412	1.64	1439	1.70	1467	1.74	1495	1.78
2700	1323	1.52	1353	1.58	1382	1.65	1409	1.72	1435	1.77	1462	1.82	1490	1.86	1517	1.90
2800	1351	1.65	1380	1.72	1407	1.78	1434	1.85	1460	1.90	1486	1.95	1513	1.99	1541	2.02
2900	1379	1.79	1407	1.86	1434	1.92	1460	1.98	1485	2.04	1511	2.08	1538	2.12	1565	2.15

BLOWER DATA

BELT DRIVE KIT SPECIFICATIONS - STANDARD EFFICIENCY - 036-074

Model No.	Motor HP		No. of Speeds	Drive Kits and RPM Range							
	Nominal	Maximum		A01	A02	A03	A04	A05	A06	A07	A08
036	0.75	0.86	1	673-1010	---	---	---	897-1346	---	---	---
	1	1.15	1	673-1010	---	---	---	897-1346	---	---	---
	1.5	1.7	1	673-1010	---	---	---	897-1346	---	---	---
	2	2.3	1	673-1010	---	---	---	897-1346	---	---	---
048	0.75	0.86	1	---	745-1117	---	---	---	1071-1429	---	---
	1	1.15	1	---	745-1117	---	---	---	1071-1429	---	---
	1.5	1.7	1	---	745-1117	---	---	---	1071-1429	---	---
	2	2.3	1	---	745-1117	---	---	---	1071-1429	---	---
060	0.75	0.86	1	---	---	833-1250	---	---	---	1212-1548	---
	1	1.15	1	---	---	833-1250	---	---	---	1212-1548	---
	1.5	1.7	1	---	---	833-1250	---	---	---	1212-1548	---
	2	2.3	1	---	---	833-1250	---	---	---	1212-1548	---
074	1	1.5	2	---	---	---	968-1340	---	---	---	1193-1591
	2	2.3	2	---	---	---	968-1340	---	---	---	1193-1591

NOTE - Using total air volume and system static pressure requirements determine from blower performance tables rpm and motor hp required. Maximum usable hp of motors furnished are shown. In Canada, nominal motor hp is also maximum usable motor hp. If motors of comparable hp are used, be sure to keep within the service factor limitations outlined on the motor nameplate.

BELT DRIVE KIT SPECIFICATIONS - HIGH EFFICIENCY - 036-060

Model No.	Motor HP		No. of Speeds	Drive Kits and RPM Range						
	Nominal	Maximum		A01	A02	A03	A05	A06	A07	
036	0.75	0.86	2	low 449-673 high 673-1010	---	---	---	---	---	
	1	1.15	2	---	---	---	low 598-897 high 897-1346	---	---	
048	0.75	0.86	2	---	low 497-673 high 745-1117	---	---	---	---	
	2	2.3	2	---	---	---	---	low 714-953 high 1071-1429	---	
060	1	1.15	2	---	---	low 555-833 high 833-1250	---	---	---	
	2	2.3	2	---	---	---	---	---	low 808-1032 high 1212-1548	

NOTE - Using total air volume and system static pressure requirements determine from blower performance tables rpm and motor hp required. Maximum usable hp of motors furnished are shown. In Canada, nominal motor hp is also maximum usable motor hp. If motors of comparable hp are used, be sure to keep within the service factor limitations outlined on the motor nameplate.

OPTIONS / ACCESSORIES AIR RESISTANCE - in. w.g.

Air Volume cfm	Wet Indoor Coil		Economizer	Electric Heat	Filters		
	024, 030, 036, 048	060, 074			MERV 8	MERV 13	MERV 16
800	0.01	0.01	0.04	0.01	0.04	0.05	0.04
1000	0.02	0.01	0.04	0.03	0.04	0.07	0.05
1200	0.02	0.01	0.04	0.06	0.04	0.07	0.05
1400	0.03	0.02	0.04	0.09	0.04	0.07	0.06
1600	0.04	0.03	0.04	0.12	0.04	0.07	0.08
1800	0.05	0.04	0.05	0.15	0.05	0.07	0.09
2000	0.06	0.05	0.05	0.18	0.05	0.08	0.10
2200	0.08	0.06	0.05	0.20	0.05	0.08	0.10
2400	0.09	0.07	0.05	0.22	0.05	0.08	0.11
2600	0.10	0.08	0.06	0.24	0.05	0.08	0.12
2800	0.11	0.09	0.06	0.26	0.05	0.08	
3000	0.13	0.10	0.06	0.28	0.05	0.08	

BLOWER DATA

CEILING DIFFUSERS AIR RESISTANCE (in. w.g.)

Air Volume cfm	RTD9-65S Step-Down Diffuser			FD9-65S Flush Diffuser	RTD11-95S Step-Down Diffuser			FD11-95S Flush Diffuser
	2 Ends Open	1 Side & 2 Ends Open	All Ends & Sides Open		2 Ends Open	1 Side & 2 Ends Open	All Ends & Sides Open	
800	0.15	0.13	0.11	0.11	---	---	---	---
1000	0.19	0.16	0.14	0.14	---	---	---	---
1200	0.25	0.20	0.17	0.17	---	---	---	---
1400	0.33	0.26	0.20	0.20	---	---	---	---
1600	0.43	0.32	0.20	0.24	---	---	---	---
1800	0.56	0.40	0.30	0.30	0.13	0.11	0.09	0.09
2000	0.73	0.50	0.36	0.36	0.15	0.13	0.11	0.10
2200	0.95	0.63	0.44	0.44	0.18	0.15	0.12	0.12
2400	---	----	---	---	0.21	0.18	0.15	0.14
2600	---	----	---	---	0.24	0.21	0.18	0.17
2800	---	----	---	---	0.27	0.24	0.21	0.20
3000	---	----	---	---	0.32	0.29	0.25	0.25

CEILING DIFFUSER AIR THROW DATA

Air Volume - cfm Model No.	1 Effective Throw - ft.	
	RTD9-65S	FD9-65S
800	10 - 17	14 - 18
1000	10 - 17	15 - 20
1200	11 - 18	16 - 22
1400	12 - 19	17 - 24
1600	12 - 20	18 - 25
1800	13 - 21	20 - 28
2000	14 - 23	21 - 29
2200	16 - 25	22 - 30
Model No.	RTD11-95S	FD11-95S
2600	• 24 - 29	• 19 - 24
2800	• 25 - 30	• 20 - 28
3000	• 27 - 33	• 21 - 29

POWER EXHAUST FAN PERFORMANCE

Return Air System Static Pressure - in. w.g.	Air Volume Exhausted cfm
0.00	2000
0.05	1990
0.10	1924
0.15	1810
0.20	1664
0.25	1507
0.30	1350
0.35	1210

¹ Effective throw based on terminal velocities of 75 ft. per minute.

ELECTRICAL/ELECTRIC HEAT DATA STANDARD EFFICIENCY - DIRECT DRIVE - 2 | 2.5 TON

Model No.		KHB024S4D	KHB030S4D
¹ Voltage - 60Hz		208/230V - 1 Ph	208/230V - 1 Ph
Compressor 1	Rated Load Amps	9.8	12.7
	Locked Rotor Amps	47	64
Outdoor Fan Motors (1)	Full Load Amps (total)	1.7	1.7
Service Outlet 115V GFI (amps)		15	15
Indoor Blower Motor	Horsepower	0.25	0.25
	Type	Direct	Direct
	Full Load Amps	1.8	1.8
² Maximum Overcurrent Protection	Unit Only	25	30
³ Minimum Circuit Ampacity	Unit Only	16	20

ELECTRIC HEAT DATA

Electric Heat Voltage			208V	240V	208V	240V
² Maximum Overcurrent Protection	Unit + Electric Heat	5 kW	40	45	50	50
		7.5 kW	50	60	60	60
		10 kW	70	70	70	80
³ Minimum Circuit Ampacity	Unit + Electric Heat	5 kW	39	42	42	46
		7.5 kW	50	55	54	59
		10 kW	61	68	65	72

ELECTRICAL ACCESSORIES

Disconnect	Standard Access - 0-10 kW	20W15	20W15	20W15	20W15
	Hinged Access - 0-10 kW	20W21	20W21	20W21	20W21

NOTE - All units have a minimum Short Circuit Current Rating (SCCR) of 5000 amps.

¹ Extremes of operating range are plus and minus 10% of line voltage.

² HACR type breaker or fuse.

³ Refer to National or Canadian Electrical Code manual to determine wire, fuse and disconnect size requirements.

ELECTRICAL/ELECTRIC HEAT
STANDARD EFFICIENCY - DIRECT DRIVE - 3 TON

Model No.		KHB036S4D			
¹ Voltage - 60Hz		208/230V - 1 Ph	208/230V - 3 Ph	460V - 3 Ph	575V - 3 Ph
Compressor	Rated Load Amps	15.3	8.7	4	3.6
	Locked Rotor Amps	70	70	31	27
Outdoor Fan Motors (1)	Full Load Amps (total)	1.7	1.7	1.1	0.7
Power Exhaust (1) 0.33 HP	Full Load Amps (total)	2.4	2.4	1.3	1
Service Outlet 115V GFI (amps)		15	15	15	20
Indoor Blower Motor	Horsepower	0.5	0.5	0.5	0.5
	Type	Direct	Direct	Direct	Direct
	Full Load Amps	3.9	3.9	2	2
² Maximum Overcurrent Protection	Unit Only	40	25	15	15
	with (1) 0.33 HP Power Exhaust	40	25	15	15
³ Minimum Circuit Ampacity	Unit Only	25	17	9	8
	with (1) 0.33 HP Power Exhaust	28	19	10	9

ELECTRIC HEAT DATA

Electric Heat Voltage			208V	240V	208V	240V	480V	600V
² Maximum Overcurrent Protection	Unit + 7.5 kW	Electric Heat	60	70	40	40	20	20
		15 kW	100	110	60	70	35	30
³ Minimum Circuit Ampacity	Unit + 7.5 kW	Electric Heat	59	64	37	40	20	17
		15 kW	93	103	56	62	31	26
² Maximum Overcurrent Protection	Unit + 7.5 kW	Electric Heat + Power Exhaust	70	70	40	45	25	20
		15 kW	100	110	60	70	35	30
³ Minimum Circuit Ampacity	Unit + 7.5 kW	Electric Heat + Power Exhaust	61	67	39	42	21	18
		15 kW	95	106	58	64	32	27

ELECTRICAL ACCESSORIES

Disconnect	Standard Access - 0-7.5 kW	20W15	20W15	20W15	20W15
	15 kW	20W16	20W15	20W15	20W15
	Hinged Access - 0-7.5 kW	20W21	20W21	20W21	20W21
	15 kW	20W22	20W21	20W21	20W21

NOTE - All units have a minimum Short Circuit Current Rating (SCCR) of 5000 amps.

¹ Extremes of operating range are plus and minus 10% of line voltage.

² HACR type breaker or fuse.

³ Refer to National or Canadian Electrical Code manual to determine wire, fuse and disconnect size requirements.

ELECTRICAL/ELECTRIC HEAT DATA STANDARD EFFICIENCY - DIRECT DRIVE - 4 TON

Model No.		KHB048S4D			
¹ Voltage - 60Hz		208/230V - 1 Ph	208/230V - 3 Ph	460V - 3 Ph	575V - 3 Ph
Compressor	Rated Load Amps	20	11	5.5	4.7
	Locked Rotor Amps	99	86	37	34
Outdoor Fan Motors (1)	Full Load Amps (total)	1.7	1.7	1.1	0.7
Power Exhaust (1) 0.33 HP	Full Load Amps (total)	2.4	2.4	1.3	1
Service Outlet 115V GFI (amps)		15	15	15	20
Indoor Blower Motor	Horsepower	0.5	0.5	0.5	0.5
	Type	Direct	Direct	Direct	Direct
	Full Load Amps	3.9	3.9	2	2
² Maximum Overcurrent Protection	Unit Only	50	30	15	15
	with (1) 0.33 HP Power Exhaust	50	30	15	15
³ Minimum Circuit Ampacity	Unit Only	31	20	10	9
	with (1) 0.33 HP Power Exhaust	33	22	12	10

ELECTRIC HEAT DATA

Electric Heat Voltage			208V	240V	208V	240V	480V	600V
² Maximum Overcurrent Protection	Unit + 7.5 kW	Electric Heat 15 kW	70	80	45	45	25	20
			100	110	60	70	35	30
³ Minimum Circuit Ampacity	Unit + 7.5 kW	Electric Heat 15 kW	65	70	39	42	22	18
			99	109	59	65	33	27
² Maximum Overcurrent Protection	Unit + 7.5 kW	Electric Heat + Power Exhaust 15 kW	80	80	45	50	25	20
			110	125	70	70	35	30
³ Minimum Circuit Ampacity	Unit + 7.5 kW	Electric Heat + Power Exhaust 15 kW	67	73	42	45	23	19
			101	112	61	67	34	28

ELECTRICAL ACCESSORIES

Disconnect	Standard Access - 0-7.5 kW	15 kW	22A20	22A20	22A20	22A20
			22A21	22A20	22A20	22A20
	Hinged Access - 0-7.5 kW	15 kW	22A23	22A23	22A23	22A23
			22A24	22A23	22A23	22A23

NOTE - All units have a minimum Short Circuit Current Rating (SCCR) of 5000 amps.

¹ Extremes of operating range are plus and minus 10% of line voltage.

² HACR type breaker or fuse.

³ Refer to National or Canadian Electrical Code manual to determine wire, fuse and disconnect size requirements.

ELECTRICAL/ELECTRIC HEAT DATA
STANDARD EFFICIENCY - BELT DRIVE - 3 TON

Model No.		KHB036S4B							
¹ Voltage - 60Hz		208/230V - 1 Ph		208/230V - 3 Ph		460V - 3 Ph		575V - 3 Ph	
Compressor	Rated Load Amps	15.3		8.7		4		3.6	
	Locked Rotor Amps	70		70		31		27	
Outdoor Fan Motors (1)	Full Load Amps (total)	1.7		1.7		1.1		0.7	
Power Exhaust (1) 0.33 HP	Full Load Amps (total)	2.4		2.4		1.3		1	
Service Outlet 115V GFI (amps)		15		15		15		20	
Indoor Blower Motor	Horsepower	0.75	1.5	1	2	1	2	1	2
	Type	Belt	Belt	Belt	Belt	Belt	Belt	Belt	Belt
	Full Load Amps	7.6	11	4.6	7.5	2.1	3.4	1.7	2.7
² Maximum Overcurrent Protection	Unit Only	40	45	25	25	15	15	15	15
	with (1) 0.33 HP Power Exhaust	45	45	25	30	15	15	15	15
³ Minimum Circuit Ampacity	Unit Only	29	32	18	21	9	10	7	8
	with (1) 0.33 HP Power Exhaust	31	35	20	23	10	11	8	9

ELECTRIC HEAT DATA

Electric Heat Voltage			208V	240V	208V	240V	208V	240V	208V	240V	480V	480V	600V	600V
² Maximum Overcurrent Protection	Unit + 7.5 kW	Electric Heat	70	70	70	80	40	40	40	45	20	25	20	20
	Unit + 15 kW	Electric Heat	100	110	100	110	60	70	60	70	35	35	25	30
³ Minimum Circuit Ampacity	Unit + 7.5 kW	Electric Heat	63	68	66	71	37	40	40	43	20	21	16	17
	Unit + 15 kW	Electric Heat	97	107	100	110	57	63	60	66	31	33	25	26
² Maximum Overcurrent Protection	Unit + 7.5 kW	Electric Heat + Power Exhaust	70	70	70	80	40	45	45	50	25	25	20	20
	Unit + 15 kW	Electric Heat + Power Exhaust	100	110	110	125	60	70	70	70	35	35	30	30
³ Minimum Circuit Ampacity	Unit + 7.5 kW	Electric Heat + Power Exhaust	65	70	69	74	40	43	43	46	21	23	17	18
	Unit + 15 kW	Electric Heat + Power Exhaust	99	109	102	113	59	65	62	68	33	34	26	27

ELECTRICAL ACCESSORIES

Disconnect	Standard Access - 0-7.5 kW	20W15	20W15	20W15	20W15	20W15
		15 kW	20W16	20W15	20W15	20W15
	Hinged Access - 0-7.5 kW	20W21	20W21	20W21	20W21	20W21
		15 kW	20W22	20W21	20W21	20W21

NOTE - All units have a minimum Short Circuit Current Rating (SCCR) of 5000 amps.

¹ Extremes of operating range are plus and minus 10% of line voltage.

² HACR type breaker or fuse.

³ Refer to National or Canadian Electrical Code manual to determine wire, fuse and disconnect size requirements.

ELECTRICAL/ELECTRIC HEAT DATA

STANDARD EFFICIENCY - BELT DRIVE - 4 TON

Model No.		KHB048S4B							
¹ Voltage - 60Hz		208/230V - 1 Ph		208/230V - 3 Ph		460V - 3 Ph		575V - 3 Ph	
Compressor	Rated Load Amps	20		11		5.5		4.7	
	Locked Rotor Amps	99		86		37		34	
Outdoor Fan Motors (1)	Full Load Amps (total)	1.7		1.7		1.1		0.7	
Power Exhaust (1) 0.33 HP	Full Load Amps (total)	2.4		2.4		1.3		1	
Service Outlet 115V GFI (amps)		15		15		15		20	
Indoor Blower Motor	Horsepower	0.75	1.5	1	2	1	2	1	2
	Type	Belt	Belt	Belt	Belt	Belt	Belt	Belt	Belt
	Full Load Amps	7.6	11	4.6	7.5	2.1	3.4	1.7	2.7
² Maximum Overcurrent Protection	Unit Only	50	50	30	30	15	15	15	15
	with (1) 0.33 HP Power Exhaust	50	60	30	35	15	15	15	15
³ Minimum Circuit Ampacity	Unit Only	35	38	21	23	11	12	9	10
	with (1) 0.33 HP Power Exhaust	37	41	23	26	12	13	10	11

ELECTRIC HEAT DATA

Electric Heat Voltage			208V	240V	208V	240V	208V	240V	208V	240V	480V	480V	600V	600V
² Maximum Overcurrent Protection	Unit + 7.5 kW	Electric Heat	80	80	80	80	45	45	45	50	25	25	20	20
	Unit + 15 kW	Electric Heat	110	125	110	125	60	70	70	70	35	35	30	30
³ Minimum Circuit Ampacity	Unit + 7.5 kW	Electric Heat	69	74	72	77	40	43	43	46	22	23	18	19
	Unit + 15 kW	Electric Heat	103	113	106	116	60	66	63	69	33	34	27	28
² Maximum Overcurrent Protection	Unit + 7.5 kW	Electric Heat + Power Exhaust	80	80	80	90	45	50	50	50	25	25	20	20
	Unit + 15 kW	Electric Heat + Power Exhaust	100	110	110	125	70	70	70	80	35	40	30	30
³ Minimum Circuit Ampacity	Unit + 7.5 kW	Electric Heat + Power Exhaust	71	76	74	80	42	46	45	48	23	24	19	20
	Unit + 15 kW	Electric Heat + Power Exhaust	105	115	108	119	62	68	65	71	34	36	28	29

ELECTRICAL ACCESSORIES

Disconnect	Standard Access - 0-7.5 kW	22A20	22A20	22A20	22A20	22A20
	15 kW	22A21	22A20	22A20	22A20	22A20
	Hinged Access - 0-7.5 kW	22A23	22A23	22A23	22A23	22A23
	15 kW	22A24	22A23	22A23	22A23	22A23

NOTE - All units have a minimum Short Circuit Current Rating (SCCR) of 5000 amps.

¹ Extremes of operating range are plus and minus 10% of line voltage.

² HACR type breaker or fuse.

³ Refer to National or Canadian Electrical Code manual to determine wire, fuse and disconnect size requirements.

ELECTRICAL/ELECTRIC HEAT DATA

STANDARD EFFICIENCY - BELT DRIVE - 5 TON

Model No.		KHB060S4B							
¹ Voltage - 60Hz		208/230V - 1 Ph		208/230V - 3 Ph		460V - 3 Ph		575V - 3 Ph	
Compressor	Rated Load Amps	22.1		13.5		8		5	
	Locked Rotor Amps	125		109		59		40	
Outdoor Fan Motors (1)	Full Load Amps (total)	2.4		2.4		1.3		1	
Power Exhaust (1) 0.33 HP	Full Load Amps (total)	2.4		2.4		1.3		1	
Service Outlet 115V GFI (amps)		15		15		15		20	
Indoor Blower Motor	Horsepower	0.75	1.5	1	2	1	2	1	2
	Type	Belt	Belt	Belt	Belt	Belt	Belt	Belt	Belt
	Full Load Amps	7.6	11	4.6	7.5	2.1	3.4	1.7	2.7
² Maximum Overcurrent Protection	Unit Only	50	60	35	40	20	20	15	15
	with (1) 0.33 HP Power Exhaust	60	60	35	40	20	20	15	15
³ Minimum Circuit Ampacity	Unit Only	38	42	24	27	14	15	9	10
	with (1) 0.33 HP Power Exhaust	41	44	27	30	15	16	10	11

ELECTRIC HEAT DATA

Electric Heat Voltage			208V	240V	208V	240V	208V	240V	208V	240V	480V	480V	600V	600V
² Maximum Overcurrent Protection	Unit + Electric Heat	7.5 kW	80	90	90	90	50	50	50	50	30	30	20	20
		15 kW	110	125	110	125	70	70	70	80	40	40	30	30
		22.5 kW	150	175	150	175	90	100	90	100	50	50	40	40
³ Minimum Circuit Ampacity	Unit + Electric Heat	7.5 kW	72	77	75	81	44	47	47	50	25	26	18	19
		15 kW	106	116	109	120	63	69	66	72	36	38	27	28
		22.5 kW	140	155	143	159	83	92	86	95	48	49	37	38
² Maximum Overcurrent Protection	Unit + Electric Heat + Power Exhaust	7.5 kW	80	90	90	90	50	50	50	60	30	30	20	20
		15 kW	110	125	125	125	70	80	70	80	40	40	30	30
		22.5 kW	150	175	150	175	90	100	90	100	50	50	40	40
³ Minimum Circuit Ampacity	Unit + Electric Heat + Power Exhaust	7.5 kW	74	80	78	83	46	49	49	52	26	28	19	20
		15 kW	108	119	112	122	66	72	69	75	38	39	28	29
		22.5 kW	142	158	145	161	85	94	88	97	49	50	38	39

ELECTRICAL ACCESSORIES

Disconnect	Standard Access - 0-7.5 kW	22A21	22A20	22A20	22A20	22A20	22A20	
		15 kW	22A21	22A21	22A20	22A20	22A20	22A20
		22.5 kW	22A21	N/A	22A21	22A21	22A20	22A20
	Hinged Access - 0-7.5 kW	22A24	22A23	22A23	22A23	22A23	22A23	
		15 kW	22A24	22A24	22A23	22A23	22A23	
		22.5 kW	22A24	N/A	22A24	22A24	22A23	

NOTE - All units have a minimum Short Circuit Current Rating (SCCR) of 5000 amps.

¹ Extremes of operating range are plus and minus 10% of line voltage.

² HACR type breaker or fuse.

³ Refer to National or Canadian Electrical Code manual to determine wire, fuse and disconnect size requirements.

ELECTRICAL/ELECTRIC HEAT DATA

STANDARD EFFICIENCY - BELT DRIVE - 6 TON

Model No.		KHB074S4T					
¹ Voltage - 60Hz		208/230V - 3 Ph		460V - 3 Ph		575V - 3 Ph	
Compressor	Rated Load Amps	17.6		8.5		6.3	
	Locked Rotor Amps	136		66.1		55.3	
Outdoor Fan Motor	Full Load Amps	3		1.5		1.2	
Power Exhaust (1) 0.33 HP	Full Load Amps	2.4		1.3		1	
Service Outlet 115V GFI (amps)		15		15		20	
Indoor Blower Motor	Horsepower	1	2	1	2	1	2
	Type	Belt (2 Speed)	Belt (2 Speed)	Belt (2 Speed)	Belt (2 Speed)	Belt (2 Speed)	Belt (2 Speed)
	Full Load Amps	4.6	7.5	2.1	3.4	1.7	2.7
² Maximum Overcurrent Protection	Unit Only	45	50	20	20	15	15
	With (1) 0.33 HP Power Exhaust	45	50	20	25	15	15
³ Minimum Circuit Ampacity	Unit Only	30	33	15	16	11	12
	With (1) 0.33 HP Power Exhaust	32	35	16	17	12	13

ELECTRIC HEAT DATA

Electric Heat Voltage			208	240	208	240	480	480	600	600
² Maximum Overcurrent Protection	Unit+ Electric Heat	7.5 kW	60	60	60	60	30	30	20	25
		15 kW	70	80	80	80	40	40	30	30
		22.5 kW	90	100	100	110	50	50	40	40
		30 kW	110	125	125	125	60	70	50	50
³ Minimum Circuit Ampacity	Unit+ Electric Heat	7.5 kW	50	53	53	56	26	27	20	21
		15 kW	69	75	72	78	37	39	29	30
		22.5 kW	89	98	92	101	49	50	38	39
		30 kW	108	120	111	123	60	61	47	48
² Maximum Overcurrent Protection	Unit+ Electric Heat and (1) 0.33 HP Power Exhaust	7.5 kW	60	60	60	70	30	30	25	25
		15 kW	80	80	80	90	40	40	30	35
		22.5 kW	100	100	100	110	50	60	40	40
		30 kW	125	125	125	150	70	70	50	50
³ Minimum Circuit Ampacity	Unit+ Electric Heat and (1) 0.33 HP Power Exhaust	7.5 kW	52	55	55	58	27	29	21	22
		15 kW	72	78	74	81	39	40	30	31
		22.5 kW	91	100	94	103	50	51	39	40
		30 kW	111	123	114	126	61	62	48	49

ELECTRICAL ACCESSORIES

Disconnect Kit	Standard Access - 0-15 kW	22A20	22A20	22A20	22A20
		22A21	22A21	22A20	22A20
	Hinged Access - 0-15 kW	22A23	22A23	22A23	22A23
		22A24	22A24	22A23	22A23

NOTE - All units have a minimum Short Circuit Current Rating (SCCR) of 5000 amps.

¹ Extremes of operating range are plus and minus 10% of line voltage.

² HACR type breaker or fuse.

³ Refer to National or Canadian Electrical Code manual to determine wire, fuse and disconnect size requirements.

ELECTRICAL/ELECTRIC HEAT DATA HIGH EFFICIENCY - DIRECT DRIVE - 2 TON | 3 TON

Model No.		KHB024H4E	KHB036H4E			
¹ Voltage - 60Hz		208/230V - 1 Ph	208/230V - 1 Ph	208/230V - 3 Ph	460V - 3 Ph	575V - 3 Ph
Compressor 1	Rated Load Amps	11.7	15.3	11.6	5.7	4
	Locked Rotor Amps	58.3	83	73	38	25.6
Outdoor Fan Motors (1)	Full Load Amps (total)	2.8	2.8	2.8	1.4	1.1
Power Exhaust (1) 0.33 HP	Full Load Amps (total)	2.4	2.4	2.4	1.3	1
Service Outlet 115V GFI (amps)		15	15	15	15	20
Indoor Blower Motor	Horsepower	0.33	0.50	0.50	0.50	0.50
	Type	ECM	ECM	ECM	ECM	ECM
	Full Load Amps	2.9	4.6	4.6	2.3	1.8
² Maximum Overcurrent Protection	Unit Only	30	40	30	15	15
	with (1) 0.33 HP Power Exhaust	---	40	35	15	15
³ Minimum Circuit Ampacity	Unit Only	21	27	22	11	8
	with (1) 0.33 HP Power Exhaust	---	29	25	13	9

ELECTRIC HEAT DATA

Electric Heat Voltage			208V	240V	208V	240V	208V	240V	480V	600V
² Maximum Overcurrent Protection	Unit + Electric Heat	5 kW	50	50	---	---	---	---	---	---
		7.5 kW	60	60	70	70	45	50	25	20
		10 kW	70	80	---	---	---	---	---	---
		15 kW	---	---	100	110	70	70	35	30
³ Minimum Circuit Ampacity	Unit + Electric Heat	5 kW	43	47	---	---	---	---	---	---
		7.5 kW	55	60	61	66	42	45	23	17
		10 kW	66	73	---	---	---	---	---	---
		15 kW	---	---	95	105	61	68	34	26
² Maximum Overcurrent Protection	Unit + Electric Heat + Power Exhaust	5 kW	---	---	---	---	---	---	---	---
		7.5 kW	---	---	70	70	50	50	25	20
		10 kW	---	---	---	---	---	---	---	---
		15 kW	---	---	100	110	70	70	35	30
³ Minimum Circuit Ampacity	Unit + Electric Heat + Power Exhaust	5 kW	---	---	---	---	---	---	---	---
		7.5 kW	---	---	63	68	44	47	24	18
		10 kW	---	---	---	---	---	---	---	---
		15 kW	---	---	97	108	64	70	35	27

ELECTRICAL ACCESSORIES

Disconnect	Standard Access - 0-10 kW	0-7.5 kW	20W15	---	---	---	---
		7.5 kW	---	20W15	20W15	20W15	20W15
		15 kW	---	20W16	20W15	20W15	20W15
	Hinged Access - 0-10 kW	0-7.5 kW	20W21	---	---	---	---
		7.5 kW	---	20W21	20W21	20W21	20W21
		15 kW	---	20W22	20W21	20W21	20W21

NOTE - All units have a minimum Short Circuit Current Rating (SCCR) of 5000 amps.

¹ Extremes of operating range are plus and minus 10% of line voltage.

² HACR type breaker or fuse.

³ Refer to National or Canadian Electrical Code manual to determine wire, fuse and disconnect size requirements.

ELECTRICAL/ELECTRIC HEAT DATA
HIGH EFFICIENCY - DIRECT DRIVE - 4 TON

Model No.		KHB048H4E			
¹ Voltage - 60Hz		208/230V - 1 Ph	208/230V - 3 Ph	460V - 3 Ph	575V - 3 Ph
Compressor	Rated Load Amps	21.2	14	6.4	4.6
	Locked Rotor Amps	104	83.1	41	33
Outdoor Fan Motors (1)	Full Load Amps (total)	2.8	2.8	1.4	1.1
Power Exhaust (1) 0.33 HP	Full Load Amps (total)	2.4	2.4	1.3	1
Service Outlet 115V GFI (amps)		15	15	15	20
Indoor Blower Motor	Horsepower	0.75	0.75	0.75	0.75
	Type	ECM	ECM	ECM	ECM
	Full Load Amps	6.3	6.3	3.2	2.5
² Maximum Overcurrent Protection	Unit Only	50	40	15	15
	with (1) 0.33 HP Power Exhaust	50	40	20	15
³ Minimum Circuit Ampacity	Unit Only	36	27	13	10
	with (1) 0.33 HP Power Exhaust	38	29	14	11

ELECTRIC HEAT DATA

Electric Heat Voltage			208V	240V	208V	240V	480V	600V
² Maximum Overcurrent Protection	Unit + 7.5 kW	Electric Heat	80	80	50	50	25	20
		15 kW	110	125	70	80	40	30
³ Minimum Circuit Ampacity	Unit + 7.5 kW	Electric Heat	70	75	47	50	24	19
		15 kW	104	114	66	72	36	28
² Maximum Overcurrent Protection	Unit + 7.5 kW	Electric Heat + Power Exhaust	80	90	50	60	30	20
		15 kW	110	125	70	80	40	30
³ Minimum Circuit Ampacity	Unit + 7.5 kW	Electric Heat + Power Exhaust	72	78	49	52	26	20
		15 kW	106	117	69	75	37	29

ELECTRICAL ACCESSORIES

Disconnect	Standard Access - 0-7.5 kW	15 kW	22A20	22A20	22A20	22A20
			22A21	22A20	22A20	22A20
	Hinged Access - 0-7.5 kW	15 kW	22A23	22A23	22A23	22A23
			22A24	22A23	22A23	22A23

NOTE - All units have a minimum Short Circuit Current Rating (SCCR) of 5000 amps.

¹ Extremes of operating range are plus and minus 10% of line voltage.

² HACR type breaker or fuse.

³ Refer to National or Canadian Electrical Code manual to determine wire, fuse and disconnect size requirements.

ELECTRICAL/ELECTRIC HEAT DATA
HIGH EFFICIENCY - DIRECT DRIVE - 5 TON

Model No.		KHB060H4E			
¹ Voltage - 60Hz		208/230V - 1 Ph	208/230V - 3 Ph	460V - 3 Ph	575V - 3 Ph
Compressor	Rated Load Amps	27.1	16.5	7.2	5.5
	Locked Rotor Amps	152.9	110	52	38.9
Outdoor Fan Motors (1)	Full Load Amps (total)	2.8	2.8	1.4	1.1
Power Exhaust (1) 0.33 HP	Full Load Amps (total)	2.4	2.4	1.3	1
Service Outlet 115V GFI (amps)		15	15	15	20
Indoor Blower Motor	Horsepower	1	1	1	1
	Type	ECM	ECM	ECM	ECM
	Full Load Amps	8.4	8.4	4.2	3.4
² Maximum Overcurrent Protection	Unit Only	70	45	20	15
	with (1) 0.33 HP Power Exhaust	70	50	20	15
³ Minimum Circuit Ampacity	Unit Only	46	32	15	12
	with (1) 0.33 HP Power Exhaust	48	35	16	13

ELECTRIC HEAT DATA

Electric Heat Voltage			208V	240V	208V	240V	480V	600V
² Maximum Overcurrent Protection	Unit +	7.5 kW	90	100	60	60	30	25
	Electric Heat	15 kW	125	125	80	80	40	30
		22.5 kW	150	175	100	100	50	40
³ Minimum Circuit Ampacity	Unit +	7.5 kW	79	85	52	55	26	21
	Electric Heat	15 kW	113	124	71	77	38	30
		22.5 kW	147	163	91	100	49	39
² Maximum Overcurrent Protection	Unit +	7.5 kW	100	100	60	60	30	25
	Electric Heat + Power Exhaust	15 kW	125	150	80	80	40	35
		22.5 kW	150	175	100	110	50	40
³ Minimum Circuit Ampacity	Unit +	7.5 kW	82	87	54	57	28	22
	Electric Heat + Power Exhaust	15 kW	116	126	74	80	39	31
		22.5 kW	150	165	93	102	50	40

ELECTRICAL ACCESSORIES

Disconnect	Standard Access - 0-7.5 kW	22A20	22A20	22A20	22A20
		22A21	22A20	22A20	22A20
		22A21	22A21	22A20	22A20
	Hinged Access - 0-7.5 kW	22A24	22A23	22A23	22A23
		22A24	22A23	22A23	22A23
		22A24	22A24	22A23	22A23

NOTE - All units have a minimum Short Circuit Current Rating (SCCR) of 5000 amps.

¹ Extremes of operating range are plus and minus 10% of line voltage.

² HACR type breaker or fuse.

³ Refer to National or Canadian Electrical Code manual to determine wire, fuse and disconnect size requirements.

ELECTRICAL/ELECTRIC HEAT DATA
HIGH EFFICIENCY - BELT DRIVE - 3 TON

Model No.		KHB036H4T					
¹ Voltage - 60Hz		208/230V - 3 Ph		460V - 3 Ph		575V - 3 Ph	
Compressor	Rated Load Amps	11.6		5.7		4	
	Locked Rotor Amps	73		38		25.6	
Outdoor Fan Motors (1)	Full Load Amps (total)	2.8		1.4		1.1	
Power Exhaust (1) 0.33 HP	Full Load Amps (total)	2.4		1.3		1	
Service Outlet 115V GFI (amps)		15		15		20	
Indoor Blower Motor	Horsepower	0.75	1	0.75	1	0.75	1
	Type	Belt (2 Speed)	Belt (2 Speed)	Belt (2 Speed)	Belt (2 Speed)	Belt (2 Speed)	Belt (2 Speed)
	Full Load Amps	3.5	4.6	1.6	2.1	1.3	1.7
² Maximum Overcurrent Protection	Unit Only	30	30	15	15	15	15
	with (1) 0.33 HP Power Exhaust	30	35	15	15	15	15
³ Minimum Circuit Ampacity	Unit Only	21	22	11	11	8	8
	with (1) 0.33 HP Power Exhaust	24	25	12	12	9	9

ELECTRIC HEAT DATA

Electric Heat Voltage			208V	240V	208V	240V	480V	480V	600V	600V
² Maximum Overcurrent Protection	Unit + Electric Heat	7.5 kW	45	50	45	50	25	25	20	20
		15 kW	60	70	70	70	35	35	30	30
³ Minimum Circuit Ampacity	Unit + Electric Heat	7.5 kW	41	44	42	45	22	22	17	17
		15 kW	60	66	61	68	33	34	26	26
² Maximum Overcurrent Protection	Unit + Electric Heat + Power Exhaust	7.5 kW	50	50	50	50	25	25	20	20
		15 kW	70	70	70	70	35	35	30	30
³ Minimum Circuit Ampacity	Unit + Electric Heat + Power Exhaust	7.5 kW	43	46	44	47	23	24	18	18
		15 kW	63	69	64	70	34	35	27	27

ELECTRICAL ACCESSORIES

Disconnect	Standard Access - 0-7.5 kW	7.5 kW	20W15	20W15	20W15	20W15
		15 kW	20W15	20W15	20W15	20W15
	Hinged Access - 0-7.5 kW	7.5 kW	20W21	20W21	20W21	20W21
		15 kW	20W21	20W21	20W21	20W21

NOTE - All units have a minimum Short Circuit Current Rating (SCCR) of 5000 amps.

¹ Extremes of operating range are plus and minus 10% of line voltage.

² HACR type breaker or fuse.

³ Refer to National or Canadian Electrical Code manual to determine wire, fuse and disconnect size requirements.

ELECTRICAL/ELECTRIC HEAT DATA
HIGH EFFICIENCY - BELT DRIVE - 4 TON

Model No.		KHB048H4T					
¹ Voltage - 60Hz		208/230V - 3 Ph		460V - 3 Ph		575V - 3 Ph	
Compressor	Rated Load Amps	14		6.4		4.6	
	Locked Rotor Amps	83.1		41		33	
Outdoor Fan Motors (1)	Full Load Amps (total)	2.8		1.4		1.1	
Power Exhaust (1) 0.33 HP	Full Load Amps (total)	2.4		1.3		1	
Service Outlet 115V GFI (amps)		15		15		20	
Indoor Blower Motor	Horsepower	0.80	2	0.75	2	0.75	2
	Type	Belt (2 Speed)	Belt (2 Speed)	Belt (2 Speed)	Belt (2 Speed)	Belt (2 Speed)	Belt (2 Speed)
	Full Load Amps	3.5	7.5	1.6	3.4	1.3	2.7
² Maximum Overcurrent Protection	Unit Only	35	40	15	15	15	15
	with (1) 0.33 HP Power Exhaust	40	40	15	20	15	15
³ Minimum Circuit Ampacity	Unit Only	24	28	11	13	9	10
	with (1) 0.33 HP Power Exhaust	27	31	13	15	10	11

ELECTRIC HEAT DATA

Electric Heat Voltage			208V	240V	208V	240V	480V	480V	600V	600V
² Maximum Overcurrent Protection	Unit + Electric Heat	7.5 kW	50	50	50	60	25	25	20	20
		15 kW	70	70	70	80	35	40	30	30
³ Minimum Circuit Ampacity	Unit + Electric Heat	7.5 kW	44	47	48	51	23	25	18	19
		15 kW	63	69	67	73	34	36	27	28
² Maximum Overcurrent Protection	Unit + Electric Heat + Power Exhaust	7.5 kW	50	50	50	60	25	30	20	20
		15 kW	70	80	70	80	35	40	30	30
³ Minimum Circuit Ampacity	Unit + Electric Heat + Power Exhaust	7.5 kW	46	49	50	53	24	26	19	20
		15 kW	66	72	70	76	35	37	28	29

ELECTRICAL ACCESSORIES

Disconnect	Standard Access - 0-7.5 kW	0-7.5 kW	22A20	22A20	22A20	22A20
		15 kW	22A20	22A20	22A20	22A20
	Hinged Access - 0-7.5 kW	0-7.5 kW	22A23	22A23	22A23	22A23
		15 kW	22A23	22A23	22A23	22A23

NOTE - All units have a minimum Short Circuit Current Rating (SCCR) of 5000 amps.

¹ Extremes of operating range are plus and minus 10% of line voltage.

² HACR type breaker or fuse.

³ Refer to National or Canadian Electrical Code manual to determine wire, fuse and disconnect size requirements.

ELECTRICAL/ELECTRIC HEAT DATA
HIGH EFFICIENCY - BELT DRIVE - 5 TON

Model No.		KHB060H4T					
¹ Voltage - 60Hz		208/230V - 3 Ph		460V - 3 Ph		575V - 3 Ph	
Compressor	Rated Load Amps	16.5		7.2		5.5	
	Locked Rotor Amps	110		52		38.9	
Outdoor Fan Motors (1)	Full Load Amps (total)	2.8		1.4		1.1	
Power Exhaust (1) 0.33 HP	Full Load Amps (total)	2.4		1.3		1	
Service Outlet 115V GFI (amps)		15		15		20	
Indoor Blower Motor	Horsepower	1	2	1	2	1	2
	Type	Belt (2 Speed)	Belt (2 Speed)	Belt (2 Speed)	Belt (2 Speed)	Belt (2 Speed)	Belt (2 Speed)
	Full Load Amps	4.6	7.5	2.1	3.4	1.7	2.7
² Maximum Overcurrent Protection	Unit Only	40	45	15	20	15	15
	with (1) 0.33 HP Power Exhaust	45	45	20	20	15	15
³ Minimum Circuit Ampacity	Unit Only	29	31	13	14	10	11
	with (1) 0.33 HP Power Exhaust	31	34	14	16	11	12

ELECTRIC HEAT DATA

Electric Heat Voltage			208V	240V	208V	240V	480V	480V	600V	600V
² Maximum Overcurrent Protection	Unit + Electric Heat	7.5 kW	60	60	60	60	25	30	20	20
		15 kW	70	80	80	80	40	40	30	30
		22.5 kW	90	100	90	100	50	50	40	40
³ Minimum Circuit Ampacity	Unit + Electric Heat	7.5 kW	48	51	51	54	24	26	19	20
		15 kW	68	74	71	77	36	37	28	29
		22.5 kW	87	96	90	99	47	48	37	38
² Maximum Overcurrent Protection	Unit + Electric Heat + Power Exhaust	7.5 kW	60	60	60	60	30	30	20	25
		15 kW	70	80	80	80	40	40	30	30
		22.5 kW	90	100	100	110	50	50	40	40
³ Minimum Circuit Ampacity	Unit + Electric Heat + Power Exhaust	7.5 kW	50	53	53	56	26	27	20	21
		15 kW	70	76	73	79	37	38	29	30
		22.5 kW	90	99	92	101	48	49	38	39

ELECTRICAL ACCESSORIES

Disconnect	Standard Access - 0-7.5 kW	0-7.5 kW	22A20	22A20	22A20	22A20
		15 kW	22A20	22A20	22A20	22A20
		22.5 kW	22A21	22A21	22A20	22A20
	Hinged Access - 0-7.5 kW	0-7.5 kW	22A23	22A23	22A23	22A23
		15 kW	22A23	22A23	22A23	22A23
		22.5 kW	22A24	22A24	22A23	22A23

NOTE - All units have a minimum Short Circuit Current Rating (SCCR) of 5000 amps.

¹ Extremes of operating range are plus and minus 10% of line voltage.

² HACR type breaker or fuse.

³ Refer to National or Canadian Electrical Code manual to determine wire, fuse and disconnect size requirements.

ELECTRIC HEAT CAPACITIES

Input Voltage	5 kW			7.5 kW			10 kW		
	No of Stages	kW input	Btuh Output	No of Stages	kW input	Btuh Output	No of Stages	kW input	Btuh Output
208	1	3.8	12,800	1	5.6	19,200	1	7.5	25,600
220	1	4.2	14,300	1	6.3	21,500	1	8.4	28,700
230	1	4.6	15,700	1	6.9	23,500	1	9.2	31,400
240	1	5.0	17,100	1	7.5	25,600	1	10.0	34,200
440	---	---	---	1	6.3	21,500	---	---	---
460	---	---	---	1	6.9	23,500	---	---	---
480	---	---	---	1	7.5	25,600	---	---	---
550	---	---	---	1	6.3	21,500	---	---	---
575	---	---	---	1	6.9	23,500	---	---	---
600	---	---	---	1	7.5	25,600	---	---	---
Input Voltage	15 kW			22.5 kW			30 kW		
	No of Stages	kW input	Btuh Output	No of Stages	kW input	Btuh Output	No of Stages	kW input	Btuh Output
208	1	11.2	38,400	1	16.9	57,700	1	22.5	76,800
220	1	12.6	43,000	1	18.9	64,500	1	25.2	86,000
230	1	13.8	47,000	1	20.7	70,700	1	27.5	93,900
240	1	15.0	51,200	1	22.5	76,800	1	30.0	102,400
440	1	12.6	43,000	1	18.9	64,500	1	25.2	86,000
460	1	13.8	47,000	1	20.7	70,700	1	27.5	93,900
480	1	15.0	51,200	1	22.5	76,800	1	30.0	102,400
550	1	12.6	43,000	1	18.9	64,500	1	25.2	86,000
575	1	13.8	47,000	1	20.7	70,700	1	27.5	93,900
600	1	15.0	51,200	1	22.5	76,800	1	30.0	102,400

KHB PARTS ARRANGEMENT

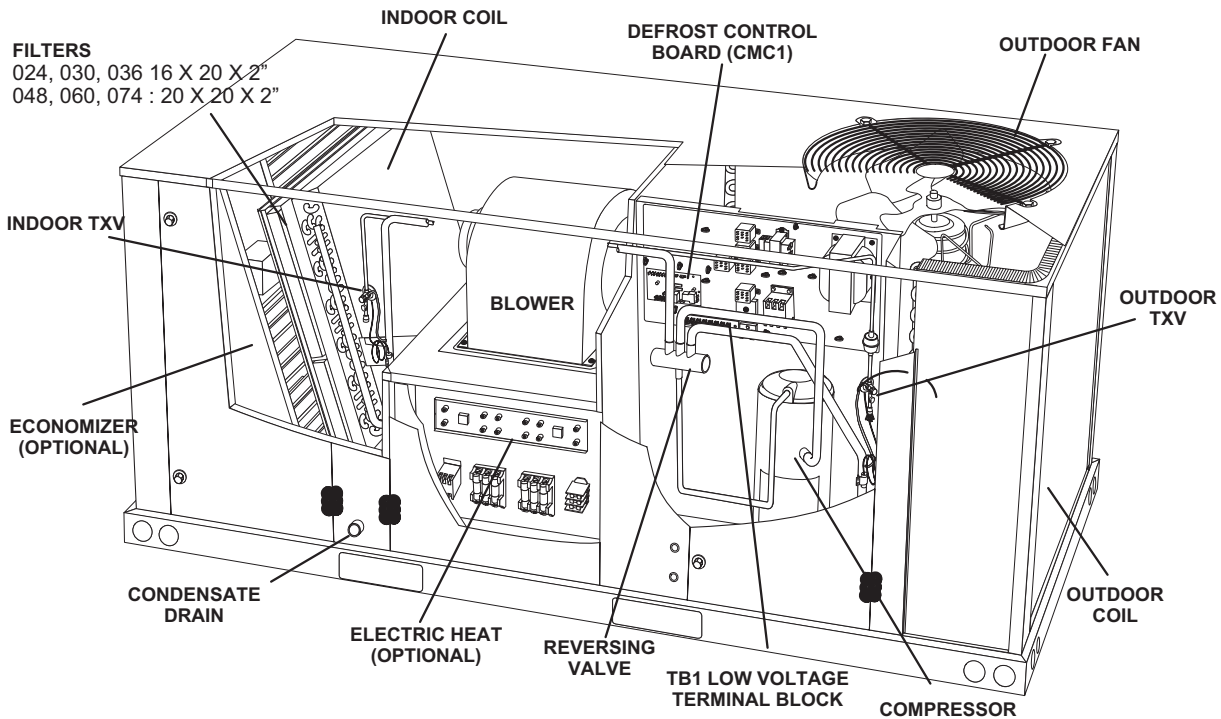

FIGURE 1

KHB CONTROL BOX

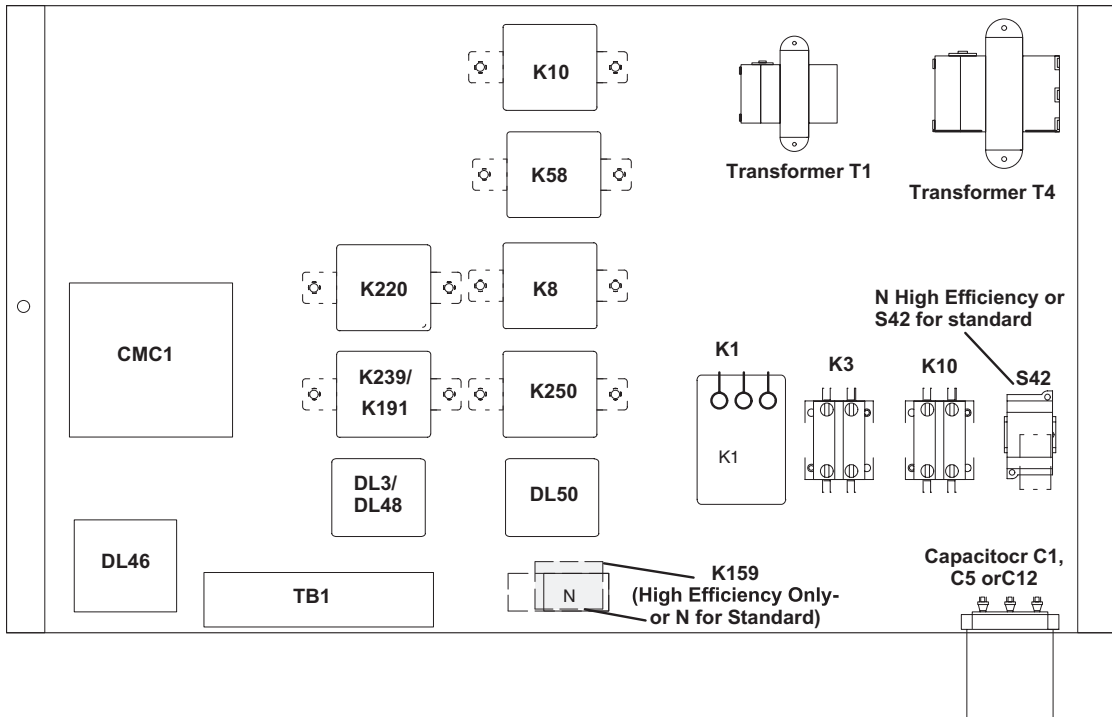

FIGURE 2

I-UNIT COMPONENTS

The KHB unit parts arrangement are shown in FIGURE 1. All L1, L2 and L3 wiring is color coded; L1 is red, L2 is yellow and L3 is blue. See wiring diagrams in the back of this manual for complete call out of components.

A-Control Box Components

KHB control box components are shown in FIGURE 2. The control box is located in the upper portion of the compressor compartment.

1-Terminal Strip TB1

All indoor thermostat connections will be to TB1 located in the control box.

2-Transformer T1

All KHB series units use a single line voltage to 24VAC transformer mounted in the control box. Transformer supplies power to control circuits in the unit. The transformer is rated at 70VA and is protected by a 3.5 amp circuit breaker (CB8). The 208/230 (P, Y) voltage transformers use two primary voltage taps as shown in FIGURE 3, while 460 (G) and 575 (J) voltage transformers use a single primary voltage tap.

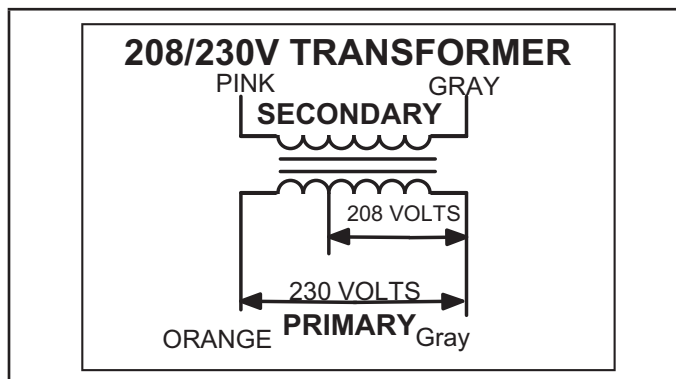

FIGURE 3

3-Outdoor Fan Capacitor C1 (Y, G, J & M)

Fan capacitors C1 (standard efficiency units only) is used to assist in the start up of condenser fan motor B4. Capacitor ratings will be on outdoor fan motor nameplate.

4-Dual Capacitor C12 & Run Capacitor C5

Single Phase Units Only Dual capacitor C12 is used on standard efficiency units and used for both the outdoor fan and compressor. The fan side and the compressor side have different MFD ratings. See side of capacitor for ratings. Run capacitor C5 is used for compressor start-up on single phase high efficiency units.

5-Compressor Contactor K1

K1 is a 24V line voltage contactor used to energize the compressor and in some cases (P and Y voltage on standard efficiency units) condenser fan in response to thermostat demand. Single phase units use single-pole double break contactors and three phase units use three-pole double break contactors.

6-Low Ambient Kit Relay K58 Standard Efficiency Units (option used with S11 low ambient switch)

Low ambient relay K58 is a N.C.DPDT relay with a 24V coil wired in parallel with reversing valve L1. When L1 is energized in the cooling cycle, K58 is also energized opening K58-1. Therefore, K58-1 is always closed during heating demand bypassing S11. This allows the fan to operate during the heating demand and cycle during the cooling demand.

7-Low Ambient Kit Relay K58, K159 High Efficiency Units (with low ambient switches S11 & S185)

Y1 or Y2 energizes K58. When liquid pressure rises to 300 ± 10 psig, S185 closes sending 24VAC through the N.C. K159-2 contacts energizing condenser fan B1 on extra low speed. (Y1, or Y2 demand).

When liquid pressure rises to 450 ± 10 psig, S11 closes, energizing K159. 24VAC energizes K159-9 (Y1) and K159-7 (Y2). Condenser fan runs at low speed with Y1 demand, and runs at high speed with demand Y2.

8-Blower Contactor K3

Blower contactor K3 is used in all standard efficiency units and belt drive high efficiency units. K3 has a 24V coil used to energize the indoor blower motor in response to blower demand. In single phase units K3 is a single-pole contactor and in three phase units K3 is a two-pole contactor.

9-Transfer Relay K8

K8 is a two-pole relay on standard efficiency units and a three-pole relay on high efficiency units. K8 has a 24V coil used to de-energize the reversing valve during a heat call. On a first stage heat call K8-1 closes de-energizing the reversing valve and K8-2 closes energizing Y1 on the CMC1 board. On high efficiency units, K8-3 closes to energize Y2 on the CMC1 board as well as high speed blower motor. Without K8 the reversing valve would remain energized at all times.

10-Transformer T4 - All J Volt Direct Drive Units and G & J Volt High Efficiency Units

Standard Efficiency Direct Drive Unit - All J (575) voltage units use transformer T4 mounted in the control box. T4 is line voltage to 460V to power the indoor blower.

High Efficiency G, J volt Units - All (G) 460 and (J) 575 voltage units use transformer T4 mounted in the control box. T4 is line voltage to 230V to power the indoor blower and outdoor fan motors on direct drive units and the outdoor fan motor only on belt drive units. T4 transformer is energized at all times.

11-Outdoor Fan Relay K10

Outdoor fan relay K10 is a DPDT relay with a 24VAC coil. K10 energizes condenser fan B4. K10 is used on all high efficiency units and standard efficiency G, J and M voltage units and with a low ambient kit on standard efficiency P and Y voltage units.

12-Blower Delay DL3 (-074 only) & DL50

When second stage heat demand is satisfied DL3 causes a 180 second blower off delay. DL50 (used on -074 and high efficiency belt drive units only) causes a 1.5 second delay switching from high speed to low speed.

13-Relay K239 -074S Units Only

Relay K239 sends the Y1 demand "G" signal to K3 (through K250) to energize the blower on low speed and also sends the "W1" demand "G" signal to K37 (through K250) to energize the blower on high speed.

14-Relay K250 High Efficiency Belt Drive Units & 074S

Relay K250 passes the "G" signal to contactor K3 energizing the blower on low speed. On a Y2 call K250 passes the signal to K37 energizing the blower on high speed. L34 is energized by CMC1 (Y2-out), when there is Y2 or W1 thermostat call.

15-Blower Contactor K37 -074 and High Efficiency Belt Drive Units

On two-speed operation K37 acts as the high speed blower contactor and K3 acts as the low speed contactor in response to blower demand.

16-Defrost Control CMC1 High Efficiency Units

The defrost system includes three components: an outdoor coil / outdoor ambient sensor, defrost thermostat and a defrost control. See unit wiring diagram to determine which controls are used in each unit. Optional controls are identified on wiring diagrams by arrows at junction points.

The defrost control ensures that the heat pump outdoor coil does not ice excessively during the heating mode. The defrost control uses input from the outdoor coil sensor and ambient temperature sensor on 100135 series defrost control boards.

Electric heat is energized by CMC1 W1 24VAC contacts during defrost.

Series 100135 (FIGURE 4)

After 34 minutes of heating mode operation, if the difference between the ambient temperature (RT13) and the coil temperature (RT21) is higher than the maximum difference allowed by the control, the defrost control will initiate defrost.

The defrost control will also initiate defrost after 6 hours of heating mode operation when coil temperatures remain below 35°F (2°C). The defrost cycle ends when the coil temperature is higher than the termination temperature (50°F default) or after 14 minutes of operation. If the defrost is terminated by the 14-minute timer, another defrost cycle will be initiated after 34 minutes of run time.

Note - The defrost termination temperature can be adjusted to 50, 70, 90 or 100°F. The jumper termination pin is factory- set at 50°F (10°C). If the temperature jumper is not installed, the default termination temperature is 90°F (32°C). See FIGURE 4.

Ambient and Coil Temperature Sensors (RT13, RT21)

Both sensors provide input to the defrost control which cycles defrost. The ambient sensor is located on the inside of the corner mullion on the back of the outdoor coil section. The coil sensor is located on a return bend on the front of the outdoor coil.

Defrost Test Option

A TEST option is provided for troubleshooting. The TEST mode may be started any time the unit is in the heating mode and the defrost thermostat is closed or jumpered. If the timing jumper is in the TEST position at power-up, the defrost control will ignore the test pins. When the jumper is placed across the TEST pins for two seconds, the control will enter the defrost mode. If the jumper is removed before an additional 5-second period has elapsed (7 seconds total), the unit will remain in defrost mode until the defrost pressure switch opens or 14 minutes have passed. If the jumper is not removed until after the additional 5-second period has elapsed, the defrost will terminate and the test option will not function again until the jumper is removed and re-applied.

High Pressure Switch

The high pressure switch is an auto reset SPST N.C. switch which opens on a pressure rise. The switch is located in the compressor discharge line and is wired to "HI PS" on the CMC1 board.

When discharge pressure rises to 640 ± 10 psig (4413 ± 69 kPa) (indicating a problem in the system) the switch opens and the CMC1 board de-energizes the compressor (the economizer can continue to operate). S4 will close when pressure drops back to 475 psig (3275 kPa).

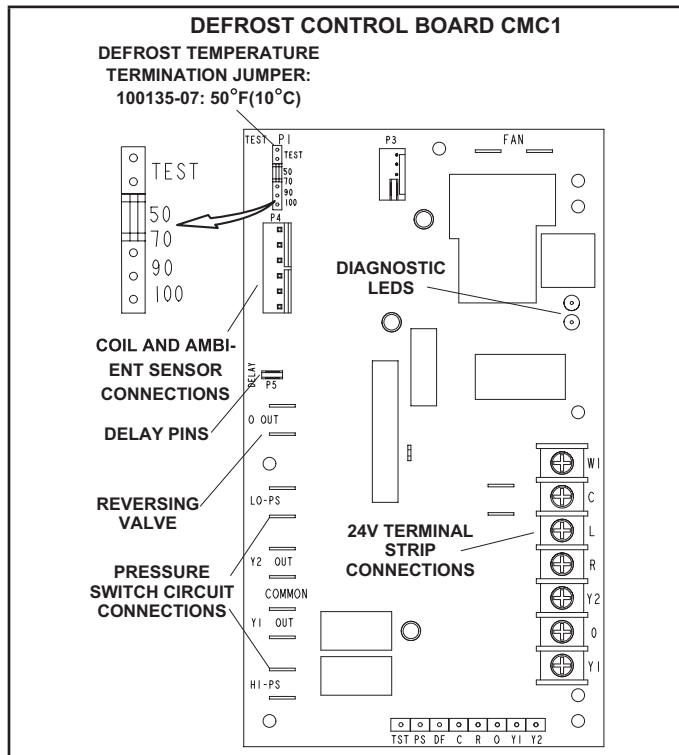

FIGURE 4

Diagnostic LEDs

The defrost board uses two LEDs for diagnostics. The LEDs flash a sequence according to the condition.

TABLE 1

Defrost Control Board Diagnostic LED

Mode	Green LED (DS2)	Red LED (DS1)
No power to control	OFF	OFF
Normal operation / power to control	Simultaneous Slow FLASH	
Anti-short cycle lock-out	Alternating Slow FLASH	
Low pressure switch, freezestat fault	OFF	Slow Flash
Low pressure switch, freezestat lockout	OFF	ON
High pressure switch fault	Slow FLASH	OFF
High pressure switch lockout	ON	OFF
Ambient sensor fault	Simultaneous Slow FLASH	
Coil sensor fault	Alternating Slow FLASH	

17-Defrost Control CMC1 Standard

Efficiency Units

The KHB defrost system includes two components: a defrost thermostat and a defrost control.

Defrost Thermostat (Defrost Switch S6)

The defrost thermostat is located on the liquid line between the outdoor check/expansion valve and the distributor. When defrost thermostat senses 42°F (5.5°C) or cooler, the thermostat contacts close and send a signal to the defrost control board to start the defrost timing. It also terminates defrost when the liquid line warms up to 70°F (21°C).

Defrost Control

The defrost control board includes the combined functions of a time/temperature defrost control, defrost relay and diagnostic LEDs. The control provides automatic switching from normal heating operation to defrost mode and back. During compressor cycle (call for defrost), the control accumulates compressor run times at 30, 60, or 90 minute field-adjustable intervals. If the defrost thermostat is closed when the selected compressor run time interval ends, the defrost relay is energized and defrost begins.

Defrost Control Timing Pins

Each timing pin selection provides a different accumulated compressor run time period. This time period must occur before a defrost cycle is initiated. The defrost interval can be adjusted to 30, 60 or 90 minutes (FIGURE 5). The defrost timing jumper is factory-installed to provide a 90-minute defrost interval. If the timing selector jumper is not in place, the control defaults to a 90-minute defrost interval. The maximum defrost period is 14 minutes and cannot be adjusted.

A TEST option is provided for troubleshooting. **The TEST mode may be started any time the unit is in the heating mode and the defrost thermostat is closed or jumpered.** If the jumper is in the TEST position at power-up, the control will ignore the test pins. When the jumper is placed across the TEST pins for two seconds, the control will enter the defrost mode. If the jumper is removed before an additional 5-second period has elapsed (7 seconds total), the unit will remain in defrost mode until the defrost thermostat opens or 14 minutes have passed. If the jumper is not removed until after the additional 5-second period has elapsed, the defrost will terminate and the test option will not function again until the jumper is removed and re-applied.

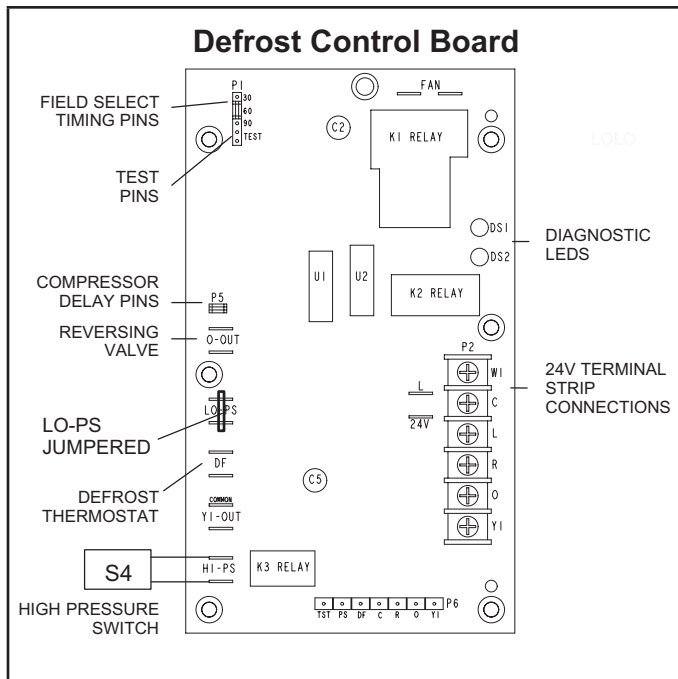

FIGURE 5

Compressor Delay

The defrost board has a field-selectable function to reduce occasional sounds that may occur while the unit is cycling in and out of the defrost mode. The compressor will be cycled off for 30 seconds going in and out of the defrost mode when the compressor delay jumper is removed.

NOTE - The 30-second compressor feature is ignored when the defrost test pins are jumpered.

Time Delay

The timed-off delay is five minutes long. The delay helps to protect the compressor from short-cycling in case the power to the unit is interrupted (demand met for example) or a pressure switch opens. The delay is bypassed by placing the timer select jumper across the TEST pins for 0.5 seconds.

Pressure Switch Circuit

The defrost control incorporates two pressure switch circuits. A high pressure switch (S4) is connected to the board's HI PS terminals (FIGURE 5). The board also includes terminals LO PS but are jumpered and not in use.

During a single demand cycle, the defrost control will lock out the unit after the fifth time that the circuit is interrupted by any switch wired to the control board. In addition, the diagnostic LEDs will indicate a locked-out switch after the fifth occurrence of an open pressure switch (see TABLE 2). The unit will remain locked out until power to the board is interrupted, then re-established or until the jumper is applied to the TEST pins for 0.5 seconds.

NOTE - The defrost control board ignores input from the LO PS terminals as follows:

during the TEST mode,

during the defrost cycle,

during the 90-second start-up period,

and for the first 90 seconds each time the reversing valve switches heat/cool modes.

Diagnostic LEDs

The defrost board uses two LEDs for diagnostics. The LEDs flash a specific sequence according to the condition.

TABLE 2

Defrost Control Board Diagnostic LED

Mode	Green LED (DS2)	Red LED (DS1)
No power to control	OFF	OFF
Normal operation / power to control	Simultaneous Slow FLASH	
Anti-short cycle lock-out	Alternating Slow FLASH	
Low pressure switch, freestat fault	OFF	Slow Flash
Low pressure switch, freestat lockout	OFF	ON
High pressure switch fault	Slow FLASH	OFF
High pressure switch lockout	ON	OFF
Ambient sensor fault	Simultaneous Slow FLASH	
Coil sensor fault	Alternating Slow FLASH	

KHB PLUMBING and S49 FREEZESTAT LOCATION

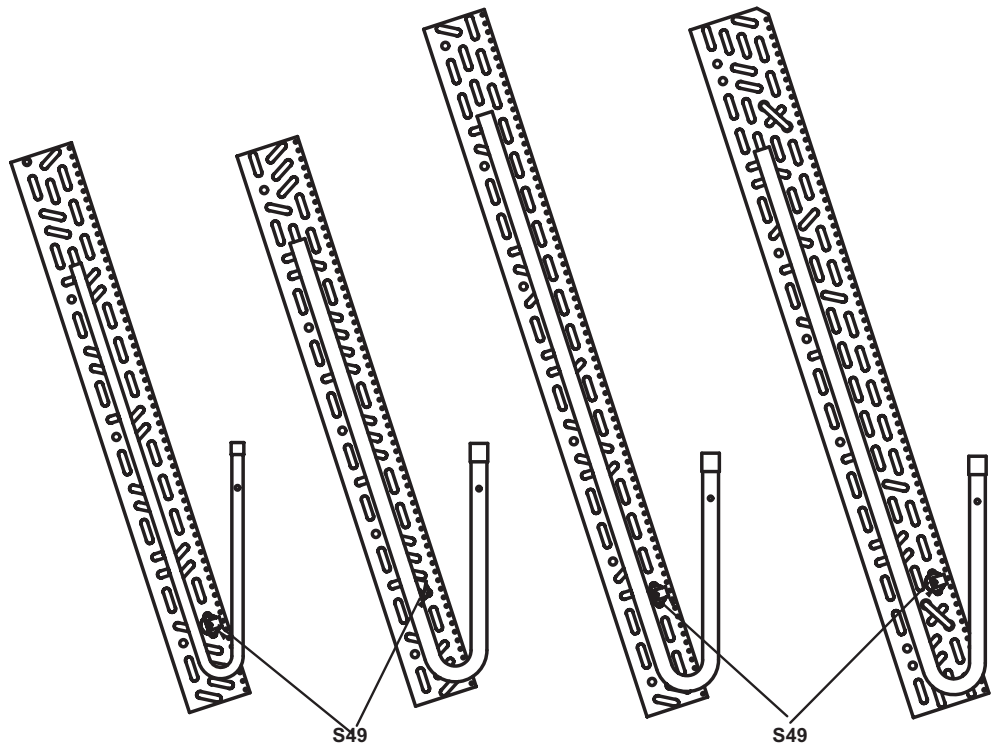
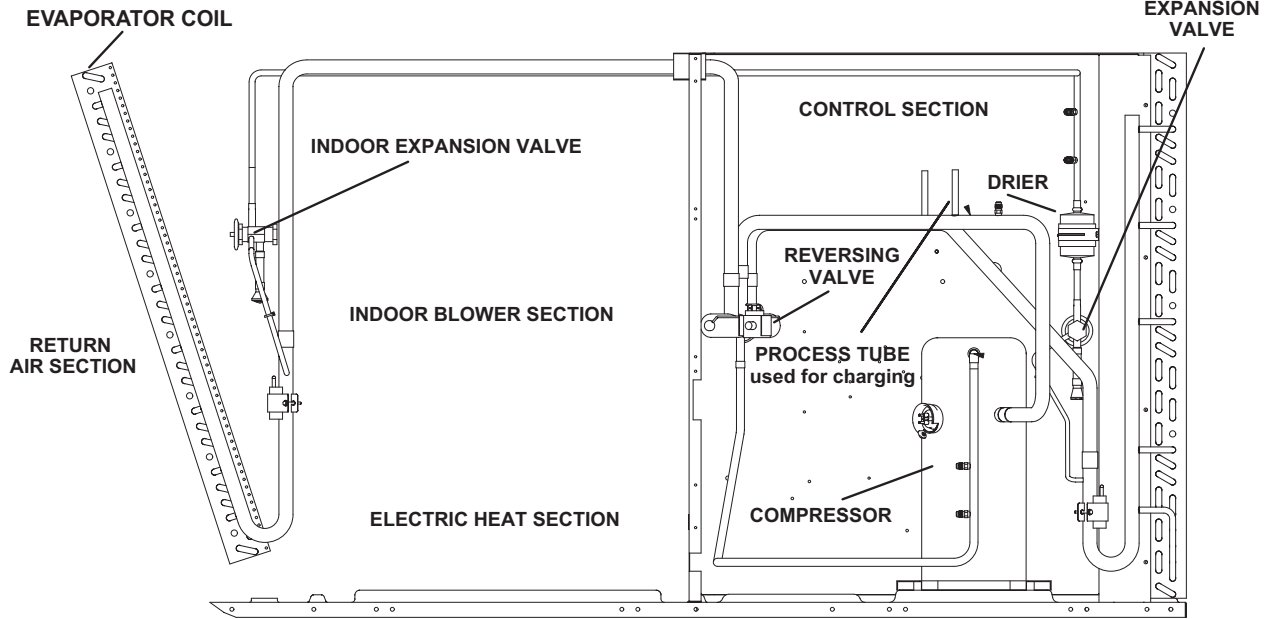

KHB024,030

KHB036

KHB048

KHB060

FIGURE 6

B-Cooling Components

If Interlink compressor replacement is necessary, call 1-800-453-6669.

IMPORTANT

Some scroll compressors have an internal vacuum protector that will unload scrolls when suction pressure goes below 20 psig. A hissing sound will be heard when the compressor is running unloaded. Protector will reset when low pressure in system rises above 40 psig. DO NOT REPLACE COMPRESSOR.

KHB units use one cooling circuit consisting of a compressor, outdoor coil and indoor coil. See FIGURE 6. Units are equipped with one draw-through type condenser fan. All units are equipped with indoor blowers which draw air across the indoor coil during unit operation. KHB units have three condensate drain locations: front, back and bottom of unit. See unit installation instructions for more detail.

Cooling may be supplemented by a factory or field-installed economizer. The indoor coil is slab type. The indoor coil uses a thermostatic check/expansion valve as the primary expansion device. The indoor coil is also equipped with enhanced fins and rifled tubing. In all units the compressor is protected by a freezestat (S49) (on the indoor coil) and a high pressure switch (S4). A low ambient switch (S11) is available as an option for additional compressor protection.

1-Compressor B1

All KHB024-074 units use scroll compressor. See "SPECIFICATIONS" and "ELECTRICAL DATA" (table of contents) or compressor nameplate for compressor specifications.

WARNING

Electrical shock hazard. Compressor must be grounded. Do not operate without protective cover over terminals. Disconnect power before removing protective cover. Discharge capacitors before servicing unit. Failure to follow these precautions could cause electrical shock resulting in injury or death.

The compressor is energized by a corresponding compressor contactor.

NOTE-Refer to the wiring diagram section for specific unit operation.

2-Freezestat S49

Each unit is equipped with a low temperature switch (freezestat) located on the return bend of the indoor coil. The freezestat is wired in series with stage one cooling control circuit (see wiring diagram). The switch is a SPST N.C. auto-reset switch which opens at $29^{\circ}\text{F} \pm 3^{\circ}\text{F}$ ($-1.7^{\circ}\text{C} \pm 1.7^{\circ}\text{C}$) on a temperature drop and closes at $58^{\circ}\text{F} \pm 4^{\circ}\text{F}$ ($14.4^{\circ}\text{C} \pm 2.2^{\circ}\text{C}$) on a temperature rise.

To prevent coil icing, the freezestat opens during compressor operation to temporarily disable the compressor until the coil warms sufficiently to melt any accumulated frost.

If the freezestat is tripping frequently due to coil icing, check the airflow, filters and unit charge before allowing unit back in operation. Make sure to eliminate conditions which might promote indoor coil ice buildup.

3-High Pressure Switch S4

The high pressure switch is an auto reset SPST N.C. switch which opens on a pressure rise. The switch is located in the compressor discharge line and is wired to "HI PS" on the CMC1 board.

When discharge pressure rises to 640 ± 10 psig (4413 ± 69 kPa) (indicating a problem in the system) the switch opens and the CMC1 board de-energizes the compressor (the economizer can continue to operate). S4 will close when pressure drops back to 475 psig (3275 kPa).

4-Low Ambient Switch S11 (option)

Standard Efficiency Models:The low ambient switch is an auto-reset SPST N.O. pressure switch which allows for mechanical cooling operation at low outdoor temperatures. In all models a switch is located in the liquid line prior to the indoor coil section.

In the P and Y voltage units S11 is wired in series with the K1 contactor and the CMC1 board fan contacts. In G, J and M voltage units S11 in series with outdoor fan relay K10 and low ambient relay K58 (if used).

When liquid pressure rises to 450 ± 10 psig (3102 ± 69 kPa), the switch closes and the condenser fan is energized. When discharge pressure in drops to 240 ± 10 psig (1655 ± 69 kPa), the switch opens and the condenser fan in that refrigerant circuit is de-energized. This intermittent fan operation results in higher evaporating temperature allowing the system to operate without icing the indoor coil and losing capacity.

High Efficiency Models: The low ambient switches are auto-reset SPST N.O. pressure switches which allow for mechanical cooling operation at low outdoor temperatures.

In all models the switches are installed on a valve depressor tee, which is located in each liquid line prior to the indoor coil section and wired in series with outdoor fan relay K10 coil.

S185 opens at 180 ± 10 psig, and closes at 300 ± 10 psig. S11 opens at 240 ± 10 psig, and closes at 450 ± 10 psig. When liquid pressure rises to 300 ± 10 psig, the S185 switch closes and the condenser fan runs at extra low speed (300 rpm). When liquid pressure rises to 450 ± 10 psig, the S11 switch closes and the condenser fan runs normal cooling speed (low or high). When the liquid pressure drops to 240 ± 10 psig, the S11 switch opens and the condenser fan runs at extra low speed (300rpm). When the liquid pressure drops to 180 ± 10 psig, the S185 switch opens and the condenser fan is de-energized. This intermittent fan operation results in higher evaporating temperature allowing the system to operate without icing the evaporator coil and losing capacity.

5-Reversing Valve L1

A refrigerant reversing valve with a 24 volt solenoid coil is used to reverse refrigerant flow during unit operation in all KHB units. The reversing valve is connected in the vapor line of the refrigerant circuit. The reversing valve coil is energized during cooling demand and during defrost.

Reversing valve L1 is controlled by the CMC1 board and transfer relay K8 in response to cooling demand or by defrost.

6-Condenser Fan Motor B4

See specifications section of this manual for specifications of condenser fan B4. In standard efficiency P and Y voltage units B4 is energized by contactor K1. In G and J voltage units K10 energizes B4. All motors are ball bearing type single-phase motors. In high efficiency units B4 is energized by K10 and all motors are ball bearing type variable speed EC motors. For all units the fans may be removed for servicing and cleaning by removing the fan grilles.

7-Low Temperature Switch S3 (option)

S3 is a SPST bimetal thermostat which opens on temperature drop. It is wired in line with the indoor thermostat and transfer relay K8. In the cooling mode, when outdoor temperature drops below 40° F (4.5° C) the switch opens and de-energizes the compressor. When the compressor is deenergized the cooling demand is handled by the economizer. The switch automatically resets when outdoor temperature rises to 50° F (10° C).

8-Filter Drier (all units)

KHB units have a filter drier located in the liquid line of the refrigerant circuit at the exit of the condenser coil. The drier removes contaminants and moisture from the system. Replacement must be suitable for R-410A refrigerant.

9-Crankcase Heater HR1 & Thermostat S40

All units have a crankcase heater. HR1 prevents migration of liquid refrigeration into the compressor and ensures proper compressor lubrication. The S40 switch is located on the liquid line on standard efficiency P voltage units. The switch will open when temperature rises above 70°, de-energizing the crankcase heater. The switch closes when temperature drops to 50°F energizing the crankcase heater.

The KHB074 is equipped with S40, a N.C. thermostat located on the discharge line which opens when discharge line temperature rises above 94°F (34°C). When S40 opens the crankcase heater is de-energized. The thermostat closes when discharge line temperature drops below 74°F (23°C) energizing the crankcase heater.

10-Crankcase Heater Delay DL48 & Crankcase Heater Relay K191

Delay DL48 and relay K191 keep crankcase heater de-energized during and immediately following compressor shut down. They ensure the crankcase heater is off while compressor is energized.

C-Blower Compartment

Units are equipped with either direct drive or belt drive blowers. See units 'Specifications' and or unit nameplate for blower type. The blower compartment in all units is located between the evaporator coil and the compressor compartment.

1-Blower Wheels

See unit "Specifications" for blower wheel dimensions per model.

2-Indoor Blower Motor Capacitor C4

All single phase standard efficiency unit blower motors are PSC and requires a run capacitor. Ratings may vary from each motor. See motor nameplate for capacitor ratings.

3-Indoor Blower Motor B3

All high efficiency units use direct drive ECM or two speed belt drive motor. All standard efficiency direct drive units use single single phase PSC motors. Belt drive units use single or three phase motors (same as supply voltage). CFM adjustments on belt drive units are made by adjusting the motor pulley (sheave). CFM adjustments on direct drive units are made by changing speed taps. Belt drive motors are equipped with sealed ball bearings. Direct drive motors are equipped with sleeve bearings. Units may be equipped with motors manufactured by various manufacturers, therefore electrical FLA and LRA specifications will vary. See unit rating plate for information specific to your unit.

OPERATION / ADJUSTMENT

IMPORTANT

Three phase scroll compressors must be phased sequentially for correct compressor and blower rotation. Follow "COOLING START-UP" section of installation instructions to ensure proper compressor and blower operation.

A-Blower Operation

Initiate blower demand at thermostat according to instructions provided with thermostat. Unit will cycle on thermostat demand. The following steps apply to applications using a typical electro-mechanical thermostat.

- Blower operation is manually set at the thermostat subbase fan switch. With fan switch in ON position, blowers will operate continuously.
- With fan switch in AUTO position, the blowers will cycle with demand. Blowers and entire unit will be off when system switch is in OFF position.

B-Determining Unit CFM - Direct Drive Blowers

- The following measurements must be made with air filters in place and no cooling demand.
- With all access panels in place, measure static pressure external to unit (from supply to return). Add any additional air resistance for options and accessories shown in air resistance table.
- Use FIGURE 7 to determine the factory set blower speed.

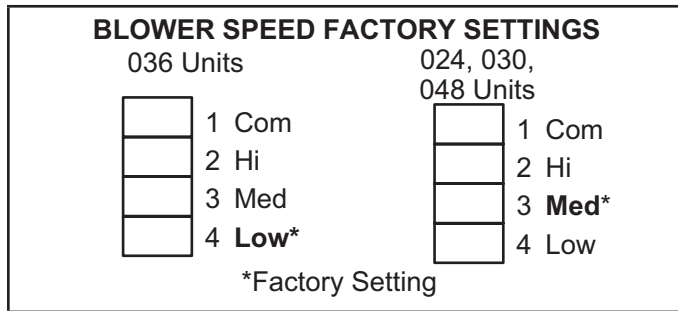

FIGURE 7

- Use the blower tables (see table of contents), measured static pressure and the factory-set blower speed to determine CFM. If CFM is lower than the design specified CFM, move the lead from speed tap 3 or 4 to speed tap 2. FIGURE 8.

Note - Speed tap 3 can be used on 036 units if speed tap 2 delivers more CFM than required by design specification. For 460/575V units, remove the isolation lead from speed tap 2 before moving the wire to speed tap 2. Tape the exposed end of the isolation lead and secure away from other components. See FIGURE 8.

C-Determining Unit CFM - Belt Drive Blowers

IMPORTANT - KHB074 blower (G thermostat) **CFM MUST BE ADJUSTED IN HIGH SPEED.** Disconnect factory-installed J350 low speed connector from P350. Connectors are located near the bottom of the control box. Connect J351 high speed connector to P350. Once blower CFM is set, J350 can be reconnected to operate the blower on low during ventilation only demands. See TABLE 3.

TABLE 3
TWO-SPEED BLOWER OPERATION
KHB074 UNITS

Thermostat	Blower Speed
G (P350/J350)*	Low
G (P350/J351)	High
W1	High
W2	High
Y1	Low
Y2	High

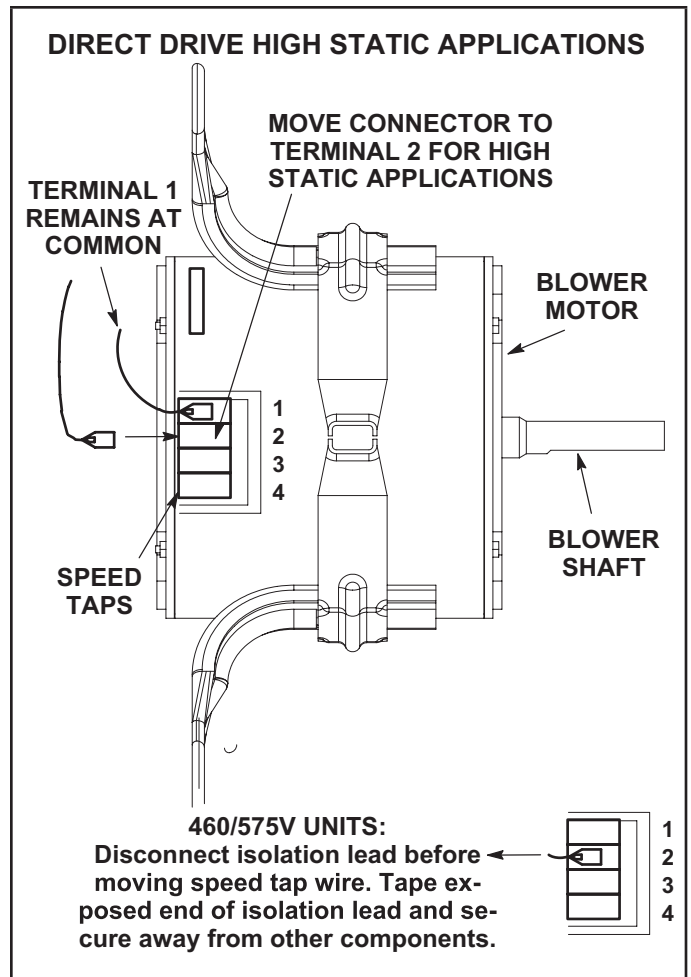

FIGURE 8

*Factory-installed jack/plug connection.

- The following measurements must be made with air filters in place and no cooling demand.
- With all access panels in place, measure static pressure external to unit (from supply to return).
- Measure the indoor blower wheel RPM.
- Referring to the blower tables use static pressure and RPM readings to determine unit CFM. Use air resistance table on when installing units with any of the options or accessories listed.
- The blower RPM can be adjusted at the motor pulley. Loosen Allen screw and turn adjustable pulley clockwise to increase CFM. Turn counterclockwise to decrease CFM. See FIGURE 12. Do not exceed minimum and maximum number of pulley turns as shown in TABLE 4.
- KHB074 Unit Only** - If low speed during ventilation is desired, replace J351 connector with J350.

TABLE 4
MINIMUM AND MAXIMUM PULLEY ADJUSTMENT

Belt	Min Turns Open	Max Turns Open
A-Section	No Minimum	5

B-Determining Unit CFM - Direct Drive Blowers

High Efficiency Units

- 1 - The following measurements must be made with air filters in place.
- 2 - With all access panels in place, measure static pressure external to unit (from supply to return). Add any additional air resistance for options and accessories shown in accessory air resistance tables. Blower performance data is based on static pressure readings taken in locations shown in FIGURE 13.

Note - Static pressure readings can vary if not taken where shown.

- 3 - Use FIGURE 9 to determine the factory-set blower speed.

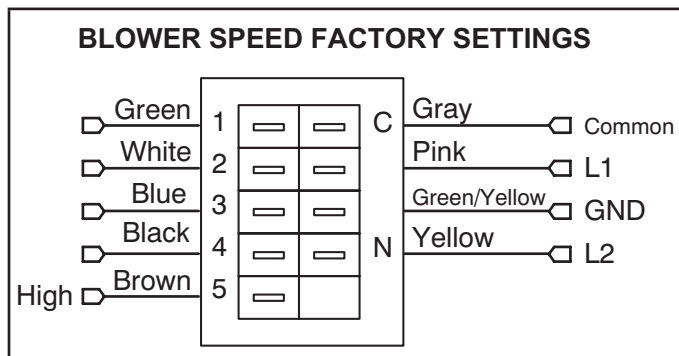

FIGURE 9

- 4 - Use direct drive blower tables, the measured static pressure and the factory-set blower speed to determine CFM. If CFM is lower or higher than the design specified CFM, move the leads as shown in FIGURE 9.

D-Blower Belt Adjustment

Maximum life and wear can be obtained from belts only if proper pulley alignment and belt tension are maintained. Tension new belts after a 24-48 hour period of operation. This will allow belt to stretch and seat grooves. Make sure blower and motor pulley are aligned as shown in FIGURE 10.

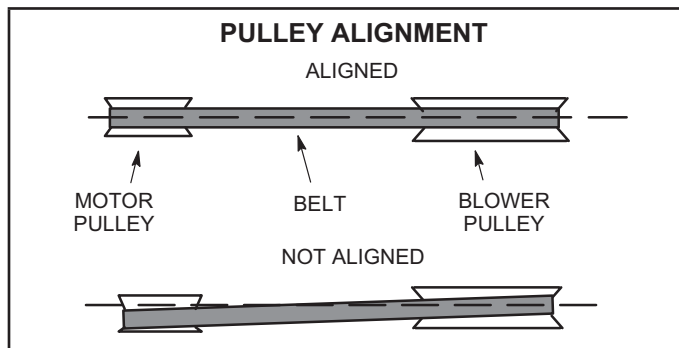

FIGURE 10

- 1 - Loosen four bolts securing motor base to mounting frame. See FIGURE 12.
- 2 - To increase belt tension -
Slide blower motor downward to tighten the belt. This increases the distance between the blower motor and the blower housing.
- 3 - To loosen belt tension -
Slide blower motor upward to loosen the belt. This decreases the distance between the blower motor and the blower housing.
- 4 - Tighten four bolts securing motor base to the mounting frame.

E-Check Belt Tension

Overtensioning belts shortens belt and bearing life. Check belt tension as follows:

- 1 - Measure span length X. See FIGURE 11.
- 2 - Apply perpendicular force to center of span (X) with enough pressure to deflect belt 1/64" for every inch of span length or 1.5mm per 100mm of span length.

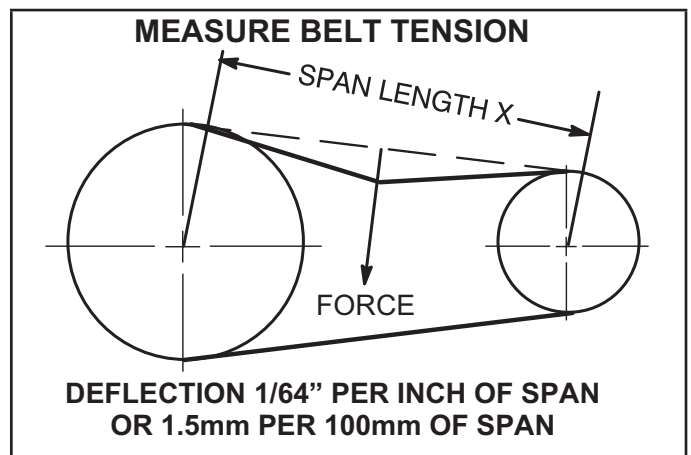

FIGURE 11

Example: Deflection distance of a 40" span would be 40/64" or 5/8".

Example: Deflection distance of a 400mm span would be 6mm.

- 3 - Measure belt deflection force. For a used belt, the deflection force should be 5 lbs. (35kPa). A new belt deflection force should be 7 lbs. (48kPa).

A force below these values indicates an undertensioned belt. A force above these values indicates an overtensioned belt.

F-Field-Furnished Blower Drives

See blower data tables for field-furnished blower drives to determine BHP and RPM required. See drive kit table on to determine the drive kit number.

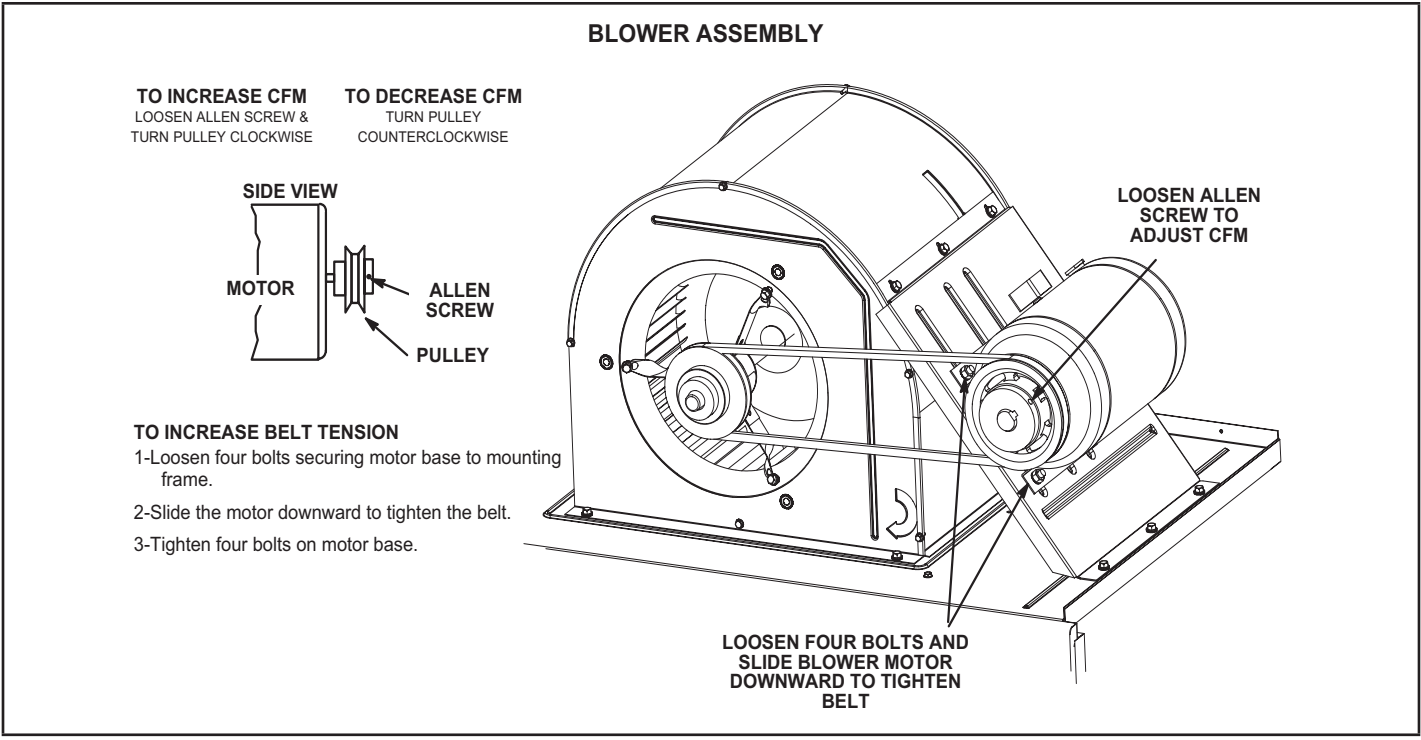

FIGURE 12

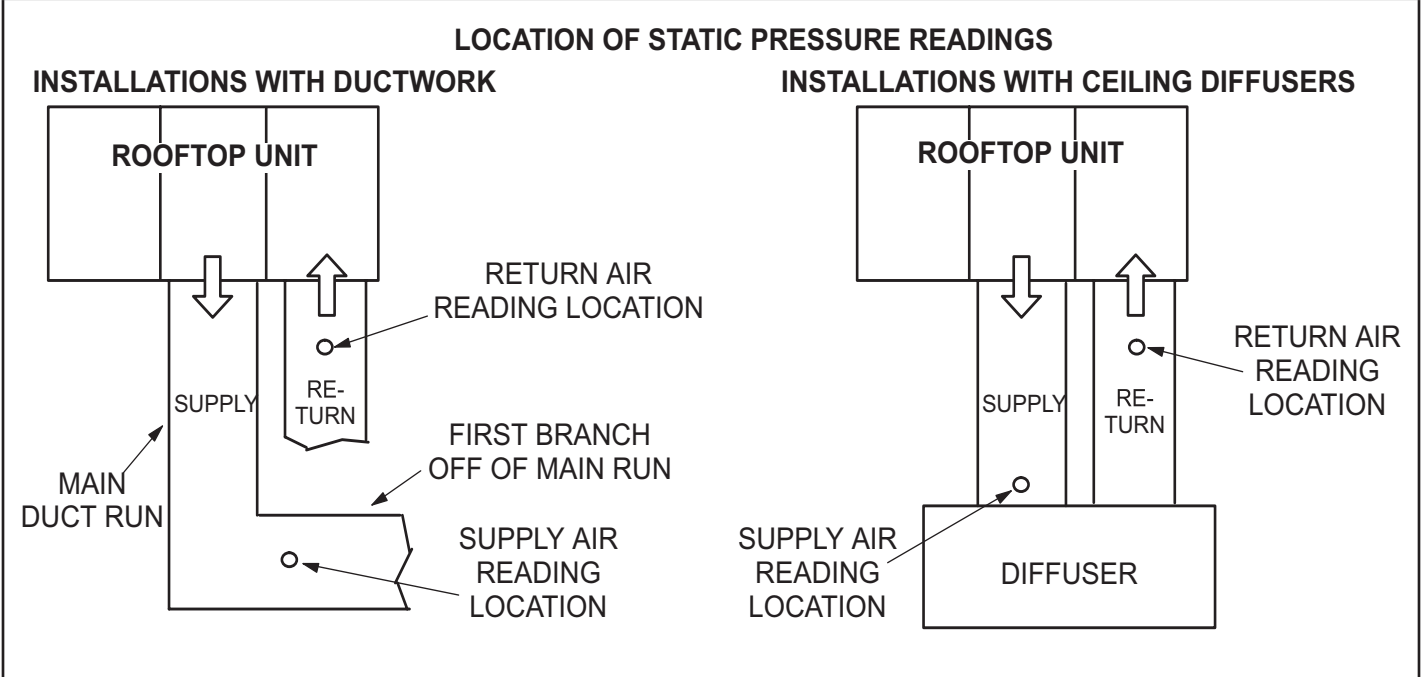

FIGURE 13

D-ELECTRIC HEAT COMPONENTS

Electric heat match-ups are found in the ELECTRICAL DATA tables. See table of contents.

All electric heat sections consist of electric heating elements exposed directly to the air stream. See FIGURE 14. See FIGURE 15 for vestibule parts arrangement.

1-Contactors K15, K16

All contactors are double break and either single, double or three pole (see diagram) and equipped with a 24VAC coil. The coils in the K15 and K16 contactors are energized by the indoor thermostat. In all units K15 energizes the heating elements, while in the 22.5 kW units, K15 and K16 energize the heating elements simultaneously.

2-High Temperature Limits S15 (Primary)

S15 is a SPST N.C. auto-reset thermostat located on the back panel of the electric heat section above the heating elements. S15 is the high temperature limit for the electric heat section. When S15 opens, indicating a problem in the system, contactor K15 is de-energized (including K16 in 22.5 kW units). When K15 is de-energized, all stages of heat are de-energized. See TABLE 5 for S15 set points. Set points are factory set and not adjustable.

TABLE 5

Unit kW (Voltage)	S15 Opens ° F	S15 Closes ° F
7.5 (Y, G, J, P)	160	120
10 (P)	170	130
15 (Y)	170	130
15 (G, J, P)	160	120
22.5 (Y, G, J)	160	120
22.5 (P)	150	110
30 (Y, G, J)	150	110

3-High Temperature Limit S20 and S157 (Secondary)

S20 and S157 are SPST N.C. manual-reset thermostats. S20 and S157 are wired in series with the heating elements. See T1EH wiring diagrams. When either limit opens K15 and K16 are de-energized. When the contactors are de-energized, all stages of heat are de-energized. The thermostat is factory set to open at $220\text{F} \pm 6^\circ\text{F}$ ($104^\circ\text{C} \pm 3.3^\circ\text{C}$) on a temperature rise and can be manually reset when temperature falls below 160°F (71°C). See FIGURE 15 for location.

4-Terminal Strip TB2

Terminal strip TB2 is used for single point power installations only. TB2 distributes power to TB3. Units with multi-point power connections will not use TB2.

5-Terminal Strip TB3

P and Y voltage units are equipped with terminal strip TB3. Electric heat line voltage connections are made to TB3, which distributes power to the electric heat components and is located on the vestibule. See FIGURE 15.

6-Heating Elements HE1 through HE6

Heating elements are composed of helix wound bare nichrome wire exposed directly to the air stream. Three elements are connected in a three-phase arrangement. The elements in 208/230V units are connected in a "Delta" arrangement. Elements in 460 and 575V units are connected in "Wye" arrangement. Each stage is energized independently by the corresponding contactors located on the electric heat vestibule panel. Once energized, heat transfer is instantaneous. High temperature protection is provided by primary and redundant high temperature limits and overcurrent protection is provided by fuses.

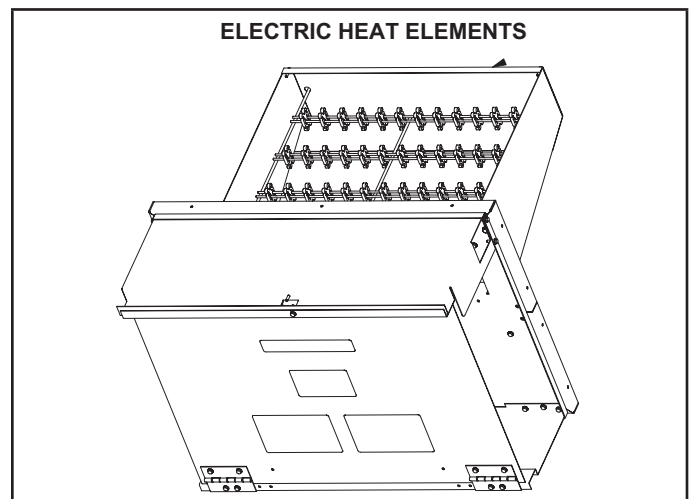

FIGURE 14

7-Fuse F3 and F42

Fuse F3 and F42 are housed in a fuse block which holds two or three fuses. Each F3 fuse is connected in series with each leg of electric heat. FIGURE 15 and TABLE 6 show the fuses used with each electric heat section.

8-Unit Fuse Block & Fuse F4

Three line voltage fuses F4 provide short circuit and ground fault protection to all cooling components in the KCA units with electric heat. The fuses are rated in accordance with the amperage of the cooling components. The F4 fuse block is located inside a sheet metal enclosure.

9-Electric Heat Relay K9

K9 is a N.O. SPDT pilot relay intended to electrically isolate the unit's 24V circuit from the electric heat 24V circuit. K9 is energized by the indoor thermostat. K9-1 closes, energizing contactor K15.

TABLE 6

Unit	Voltage-Phase	FUSE		Qty each	Qty total
		F3	F42		
T1EH0075	208/230V-1P	40 A-250V	----	2	2
	208/230V-3P	25 A-250V	----	3	3
	460V-3P	15 A-600V	----	3	3
	575V-3P	15 A-600V	----	3	3
T1EH0010	208/230V-1P	30 A-250V	30A-250V	2	2
T1EH0015	208/230V-1P	40 A-250V	40A-250V	2	4
	208/230V-3P	50 A-250V	----	3	3
	460V	25 A-600V	----	3	3
	575V	20 A-600V	----	3	3
T1EH00225	208/230V-1P	40 A-250V	40A-250V	3	6
	208/230V-3P	45 A-250V	45A-250V	3	6
	460V-3P	35 A-600V	----	3	3
	575V-3P	30 A-600V	----	3	3
T1EH0300	208/230V-3P	60 A-250V	60A-250V	3	6
	460V-3P	50 A-600V	----	3	3
	575V-3P	40 A-600V	----	3	3

ELECTRIC HEAT VESTIBULE PARTS ARRANGEMENT

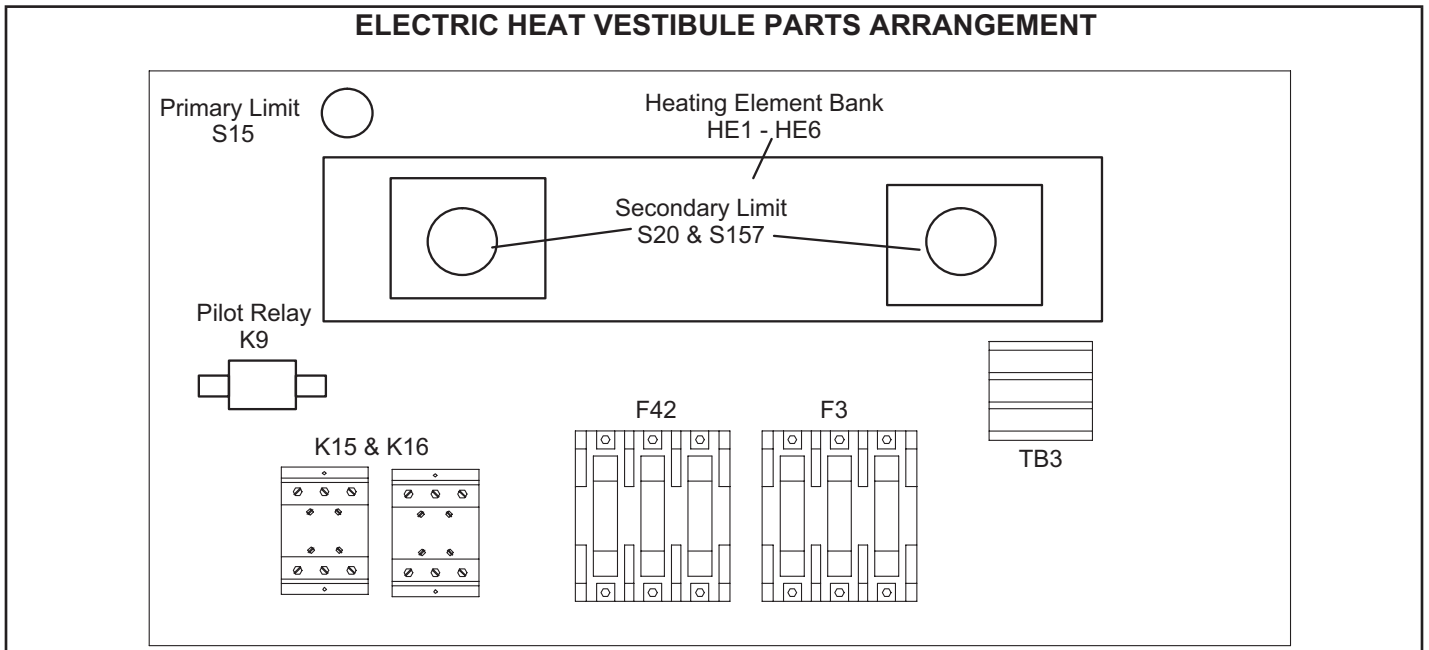

FIGURE 15

II-PLACEMENT AND INSTALLATION

Make sure the unit is installed in accordance with the installation instructions and all applicable codes. See accessories section for conditions requiring use of the optional roof mounting frame (T1CURB).

III-START UP - OPERATION

Refer to startup directions and refer closely to the unit wiring diagram when servicing. See unit nameplate for minimum circuit ampacity and maximum fuse size.

A-Preliminary and Seasonal Checks

- 1 - Make sure the unit is installed in accordance with the installation instructions and applicable codes.
- 2 - Inspect all electrical wiring, both field and factory installed for loose connections. Tighten as required. Refer to unit diagram located on inside of unit control box cover.
- 3 - Check to ensure that refrigerant lines are in good condition and do not rub against the cabinet or other refrigerant lines.
- 4 - Check voltage at the disconnect switch. Voltage must be within the range listed on the nameplate. If not, consult the power company and have the voltage corrected before starting the unit.
- 5 - Recheck voltage and amp draw with unit running. If voltage is not within range listed on unit nameplate, stop unit and consult power company. Refer to unit nameplate for maximum rated load amps.
- 6 - Inspect and adjust blower belt (see section on Blower Compartment - Blower Belt Adjustment).

B-Heating Start Up

- 1 - Set thermostat or temperature control device to initiate a first-stage heating demand.

A first-stage heating demand (W1) will energize compressor 1 and the outdoor fan.

Note - L1 reversing valve is de-energized in the heating mode.

Units With Optional Electric Heat -

An increased heating demand (W2) will energize electric heat. Electric heat is also energized during the defrost cycle to maintain discharge air temperature.

C-Cooling Start Up

IMPORTANT

If unit is equipped with a crankcase heater. Make sure heater is energized 24 hours before unit start-up to prevent compressor damage as a result of slugging.

- 1 - Initiate first and second stage cooling demands according to instructions provided with thermostat. See TABLE 7 for operation.

TABLE 7
COOLING OPERATION

T'Stat Demand	Energized	
024-060 No Economizer or Outdoor Air Unsuitable		
Y1	Compressor	Condenser Fan
Y2	Compressor	Condenser Fan
024-060 Unit Equipped With An Economizer		
Y1	Economizer	na
Y2	Economizer + Compressor	Condenser Fan
074 No Economizer or Outdoor Air Unsuitable		
Y1	Compressor Low Speed*	Condenser Fan
Y2	Compressor High Speed**	Condenser Fan
074 Unit Equipped With An Economizer		
Y1	Economizer	na
Y2	Economizer + Compressor Low Speed*	Condenser Fan

*67% of full capacity **100% of full capacity

Note - The reversing valve is energized at the same time as the compressor.

Note - KH 074 units are equipped with two-stage compressors.

- 2 - Units contain one refrigerant circuit or stage.
- 3 - Unit is charged with R-410A refrigerant. See unit rating plate for correct amount of charge.
- 4 - Refer to Refrigerant Charge and Check section for proper method to check refrigerant charge.

Three Phase Scroll Compressor Voltage Phasing

Three phase scroll compressors must be phased sequentially to ensure correct compressor and blower rotation and operation. Compressor and blower are wired in phase at the factory. Power wires are color-coded as follows: line 1-red, line 2-yellow, line 3-blue.

- 1 - Observe suction and discharge pressures and blower rotation on unit start-up.
- 2 - Suction pressure must drop, discharge pressure must rise and blower rotation must match rotation marking.

If pressure differential is not observed or blower rotation is not correct:

- 3 - Disconnect all remote electrical power supplies.
- 4 - Reverse any two field-installed wires connected to the line side of K1 contactor. **Do not reverse wires at blower contactor.**

Make sure the connections are tight.

Discharge and suction pressures should operate at their normal start-up ranges.

IV- SYSTEMS SERVICE CHECKS

Refrigerant Charge and Check KHB024/074

WARNING-Do not exceed nameplate charge under any condition.

This unit is factory charged and should require no further adjustment. If the system requires charge, reclaim the charge, evacuate the system and add required nameplate charge.

NOTE - System charging is not recommended below 60°F (15C). In temperatures below 60°F (15°C) , the charge must be weighed into the system.

If weighing facilities are not available, or to check the charge, use the following procedure:

- 1 - Attach gauge manifolds and operate unit in cooling mode until system stabilizes (approximately five minutes).
- 2 - Check each system separately with all stages operating.
- 3 - Use a thermometer to accurately measure the outdoor ambient temperature.

- 4 - Apply the outdoor temperature to TABLE 8 through TABLE 17 to determine normal operating pressures.
- 5 - Compare the normal operating pressures to the pressures obtained from the gauges. Minor variations in these pressures may be expected due to differences in installations. Significant differences could mean that the system is not properly charged or that a problem exists with some component in the system. Correct any system problems before proceeding.
- 6 - If discharge pressure is high, remove refrigerant from the system. If discharge pressure is low, reclaim the charge, evacuate the system then add refrigerant.
 - Add or remove charge in increments.
 - Allow the system to stabilize each time refrigerant is added or removed.
- 7 - Use the following approach method along with the normal operating pressures to confirm readings.

TABLE 8

KHB024S Normal Operating Pressures											
Outdoor Coil Entering Air Temperature											
65 °F		75 °F		85 °F		95 °F		105 °F		115 °F	
Suct (psig)	Disc (psig)	Suct (psig)	Disc (psig)	Suct (psig)	Disc (psig)	Suct (psig)	Disc (psig)	Suct (psig)	Disc (psig)	Suct (psig)	Disc (psig)
117	220	119	255	121	297	122	343	123	394	125	449
125	221	127	256	129	297	131	343	132	394	135	451
138	226	145	261	148	302	151	352	155	401	156	459
153	231	164	171	171	311	174	357	177	409	180	465

TABLE 9

KHB030S Normal Operating Pressures											
Outdoor Coil Entering Air Temperature											
65 °F		75 °F		85 °F		95 °F		105 °F		115 °F	
Suct (psig)	Disc (psig)	Suct (psig)	Disc (psig)	Suct (psig)	Disc (psig)	Suct (psig)	Disc (psig)	Suct (psig)	Disc (psig)	Suct (psig)	Disc (psig)
116	227	118	262	120	303	123	347	125	395	127	449
125	229	127	267	129	308	132	349	133	398	136	452
139	235	143	271	146	313	150	360	153	409	155	463
147	239	153	271	159	321	164	366	168	416	174	472

TABLE 10

KHB036S Normal Operating Pressures											
Outdoor Coil Entering Air Temperature											
65 °F		75 °F		85 °F		95 °F		105 °F		115 °F	
Suct (psig)	Disc (psig)	Suct (psig)	Disc (psig)	Suct (psig)	Disc (psig)	Suct (psig)	Disc (psig)	Suct (psig)	Disc (psig)	Suct (psig)	Disc (psig)
110	234	110	272	118	317	122	366	125	422	124	475
123	238	122	277	126	320	129	367	131	419	134	478
142	248	144	286	146	329	150	378	150	429	155	491
154	253	163	295	168	336	171	393	173	439	177	500

TABLE 11

KHB048S Normal Operating Pressures											
Outdoor Coil Entering Air Temperature											
65 °F		75 °F		85 °F		95 °F		105 °F		115 °F	
Suct (psig)	Disc (psig)	Suct (psig)	Disc (psig)	Suct (psig)	Disc (psig)	Suct (psig)	Disc (psig)	Suct (psig)	Disc (psig)	Suct (psig)	Disc (psig)
112	239	113	277	115	319	117	363	120	411	120	464
119	244	121	282	123	323	126	368	128	416	130	471
140	253	141	291	142	333	144	377	147	426	149	481
158	264	162	301	165	342	167	389	169	439	170	493

TABLE 12

KHB060S Normal Operating Pressures											
Outdoor Coil Entering Air Temperature											
65 °F		75 °F		85 °F		95 °F		105 °F		115 °F	
Suct (psig)	Disc (psig)	Suct (psig)	Disc (psig)	Suct (psig)	Disc (psig)	Suct (psig)	Disc (psig)	Suct (psig)	Disc (psig)	Suct (psig)	Disc (psig)
115	246	116	284	118	326	120	372	122	423	124	478
123	250	125	288	127	331	129	377	130	428	133	484
139	259	143	299	146	342	147	388	149	440	153	495
149	266	159	308	163	352	167	400	170	452	173	509

TABLE 13

KHB024H Normal Operating Pressures											
Outdoor Coil Entering Air Temperature											
65 °F		75 °F		85 °F		95 °F		105 °F		115 °F	
Suct (psig)	Disc (psig)	Suct (psig)	Disc (psig)	Suct (psig)	Disc (psig)	Suct (psig)	Disc (psig)	Suct (psig)	Disc (psig)	Suct (psig)	Disc (psig)
113	217	114	254	117	295	119	342	121	395	124	455
120	222	125	259	123	304	128	349	130	401	133	459
141	226	143	262	142	303	145	353	148	404	154	465
154	233	162	270	167	312	170	358	171	410	175	466

TABLE 14

KHB036H Normal Operating Pressures											
Outdoor Coil Entering Air Temperature											
65 °F		75 °F		85 °F		95 °F		105 °F		115 °F	
Suct (psig)	Disc (psig)	Suct (psig)	Disc (psig)	Suct (psig)	Disc (psig)	Suct (psig)	Disc (psig)	Suct (psig)	Disc (psig)	Suct (psig)	Disc (psig)
113	230	115	268	117	310	119	358	121	412	121	471
121	233	123	273	125	314	128	364	130	417	130	476
142	240	142	278	144	321	146	370	149	425	151	483
157	247	163	286	165	330	168	378	170	431	173	491

TABLE 15

KHB048H Normal Operating Pressures											
Outdoor Coil Entering Air Temperature											
65 °F		75 °F		85 °F		95 °F		105 °F		115 °F	
Suct (psig)	Disc (psig)	Suct (psig)	Disc (psig)	Suct (psig)	Disc (psig)	Suct (psig)	Disc (psig)	Suct (psig)	Disc (psig)	Suct (psig)	Disc (psig)
017	234	109	272	110	314	112	363	116	409	117	462
115	242	117	279	119	321	121	366	123	415	123	470
129	247	134	284	137	328	140	375	143	425	144	480
134	251	145	292	154	335	159	382	162	432	164	489

TABLE 16

KHB060H Normal Operating Pressures											
Outdoor Coil Entering Air Temperature											
65 °F		75 °F		85 °F		95 °F		105 °F		115 °F	
Suct (psig)	Disc (psig)	Suct (psig)	Disc (psig)	Suct (psig)	Disc (psig)	Suct (psig)	Disc (psig)	Suct (psig)	Disc (psig)	Suct (psig)	Disc (psig)
105	236	106	274	109	317	112	365	115	419	119	474
115	243	119	280	119	324	122	372	124	422	129	480
135	251	137	289	139	332	142	381	146	432	148	489
152	261	157	300	160	344	163	392	166	443	170	500

TABLE 17

KHB074S NORMAL OPERATING PRESSURES		
Outdoor Coil Entering Air Temp	Dis. ± 10 psig	Suct. ±5 psig
65°F	257	127
75°F	297	134
85°F	340	139
95°F	386	142
105°F	438	146
115°F	491	149

C-Charge Verification - Approach Method KHB074

- 8 - Using the same thermometer, compare liquid temperature to outdoor ambient temperature.
 Approach Temperature = Liquid temperature minus ambient temperature.
- 9 - Approach temperature should match values in TABLE 18. An approach temperature greater than value shown indicates an undercharge. An approach temperature less than value shown indicates an overcharge.
- 10 - Do not use the approach method if system pressures do not match pressures in TABLE 8 through TABLE 17. The approach method is not valid for grossly over or undercharged systems.

TABLE 18

APPROACH TEMPERATURE	
Unit	Liquid Temp. Minus Ambient Temp.
KHB074S	8°F ± 1 (4.4°C ± 0.5)

D-Refrigerant Charge and Check - KHB024-060

WARNING-Do not exceed nameplate charge under any condition.

This unit is factory charged and should require no further adjustment. If the system requires additional refrigerant, **reclaim the charge, evacuate the system, and add required nameplate charge.**

NOTE - System charging is not recommended below 60°F (15°C). In temperatures below 60°F (15°C), the charge must be weighed into the system.

If weighing facilities are not available, or to check the charge, use the following procedure:

IMPORTANT - Charge unit in standard cooling mode.

- 1 - Make sure outdoor coil is clean. Attach gauge manifolds and operate unit at full CFM in cooling mode with economizer disabled until system stabilizes (approximately five minutes). Make sure all outdoor air dampers are closed.
- 2 - Compare the normal operating pressures (see TABLE 8 through TABLE 16) to the pressures obtained from the gauges. Check unit components if there are significant differences.
- 3 - Measure the outdoor ambient temperature and the suction pressure. Refer to the appropriate circuit charging curve to determine a target liquid temperature.

Note - Pressures are listed for sea level applications.

- 4 - Use the same thermometer to accurately measure the liquid temperature (in the outdoor section).

- 5 - Add or remove charge in increments. Allow the system to stabilize each time refrigerant is added or removed.
- 6 - Continue the process until measured liquid temperature agrees with the target liquid temperature. Do not go below the target liquid temperature when adjusting charge. Note that suction pressure can change as charge is adjusted.
- 7 - **Example KHB024:** At 95°F outdoor ambient and a measured suction pressure of 130psig, the target liquid temperature is 101°F. For a measured liquid temperature of 112°F, add charge in increments until measured liquid temperature agrees with the target liquid temperature.

V-MAINTENANCE

The unit should be inspected once a year by a qualified service technician.

⚠ IMPORTANT

Label all wires prior to disconnection when servicing controls. Wiring errors can cause improper and dangerous operation. Verify proper operation after servicing.

A-Lubrication

All motors are lubricated at the factory. No further lubrication is required.

B-Filters

Units are equipped with temporary filters which need to be replaced before the building is occupied. See TABLE 19 for correct filter size. Refer to local codes or appropriate jurisdiction for approved filters.

Approved filters should be checked monthly and replaced when necessary. Take note of air flow direction marking on filter frame when reinstalling filters. See FIGURE 16.

⚠ WARNING

Units are shipped from the factory with temporary filters. Replace filters before building is occupied. Damage to unit could result if filters are not replaced with approved filters. Refer to appropriate codes.

TABLE 19

Unit	Filter Size - inches (mm)	Quantity
024, 030, 036	16 X 20 X 2 (406 X 508 X 51)	4
048, 060, 074	20 X 20 X 2 (508 X 508 X 51)	4

NOTE-Filters must be U.L.C. certified or equivalent for use in Canada

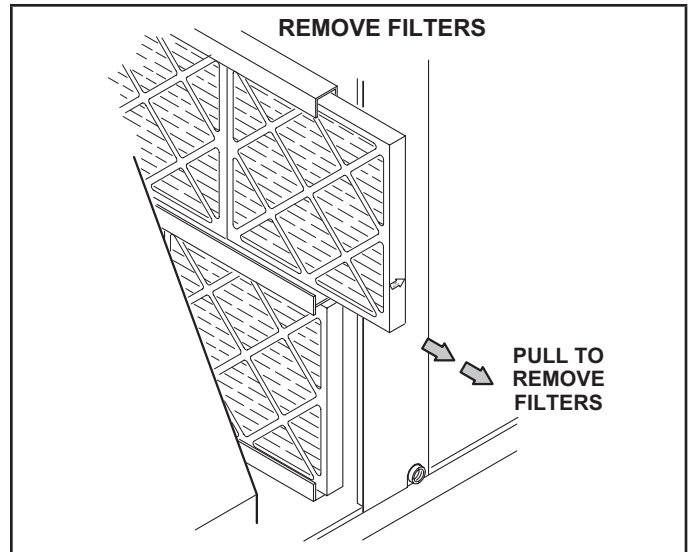

FIGURE 16

C-Supply Air Blower Wheel

Annually inspect supply air blower wheel for accumulated dirt or dust. Turn off power before attempting to remove access panel or to clean blower wheel.

D-Indoor Coil

Inspect and clean coil at beginning of each cooling and heating season. Clean using mild detergent or commercial coil cleanser. Flush coil and condensate drain with water taking care not to get insulation, filters and return air ducts wet.

E-Outdoor Coil

Clean outdoor coil annually with detergent or commercial coil cleaner and inspect monthly during the cooling season. Outdoor coils are made of single and two formed slabs. On units with two slabs, dirt and debris may become trapped between the slabs. To clean between slabs, carefully separate coil slabs and wash them thoroughly. See FIGURE 17. Flush coils with water following cleaning. Note - Remove all screws and gaskets prior to cleaning procedure and replace upon completion.

F-Filter Drier

The unit is equipped with a biflow filter drier. If replacement is necessary, order another of like design.

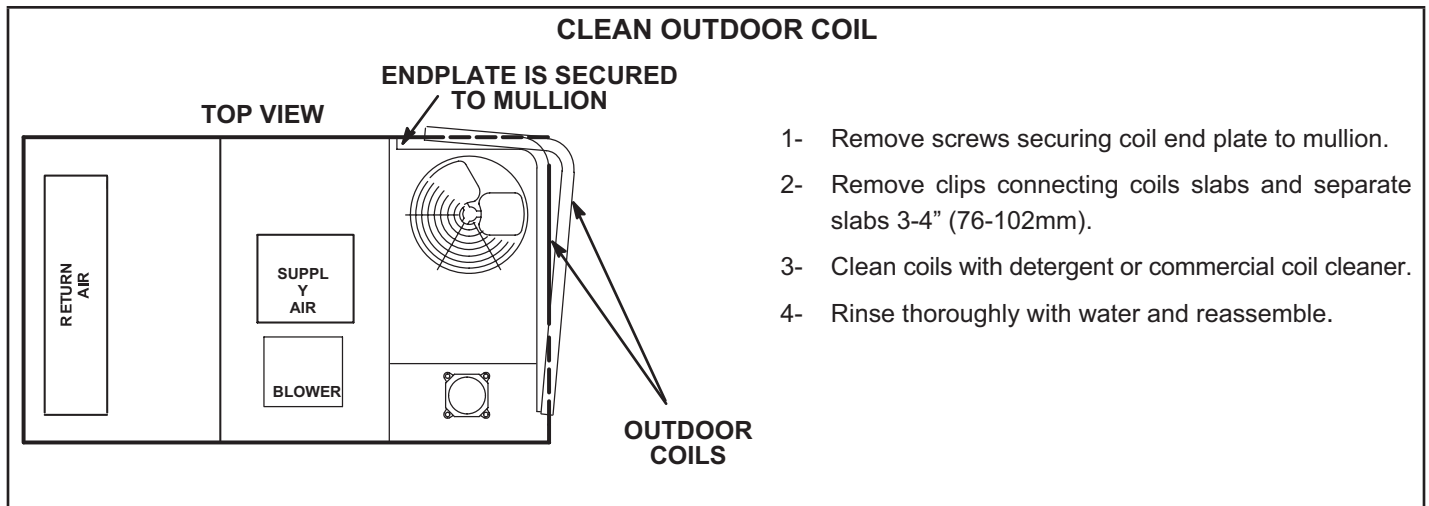

FIGURE 17

VI-ACCESSORIES

The accessories section describes the application of most of the optional accessories which can be factory or field installed to the KHB units.

A-C1CURB

When installing the KHB units on a combustable surface for downflow discharge applications, the C1CURB 8 inch, 14-inch, 18 inch or 24-inch height roof mounting frame is used. The roof mounting frames are recommended in all other applications but not required. If the units are not mounted on a flat (roof) surface, they **MUST** be supported under all edges and under the middle of the unit to prevent sagging. The units **MUST** be mounted level within 1/16" per linear foot or 5mm per meter in any direction.

The assembled mounting frame is shown in FIGURE 18. Refer to the roof mounting frame installation instructions for details of proper assembly and mounting. The roof mounting frame **MUST** be squared to the roof and level before mounting. Plenum system **MUST** be installed before the unit is set on the mounting frame. Typical roof curbing and flashing is shown in FIGURE 19. Refer to the roof mounting frame installation instructions for proper plenum construction and attachment.

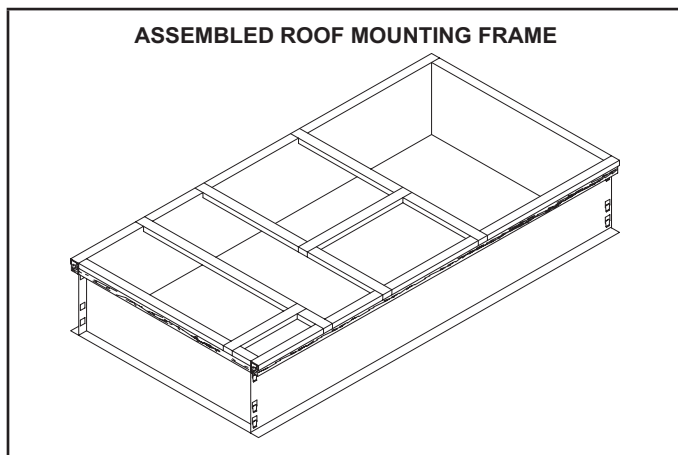

FIGURE 18

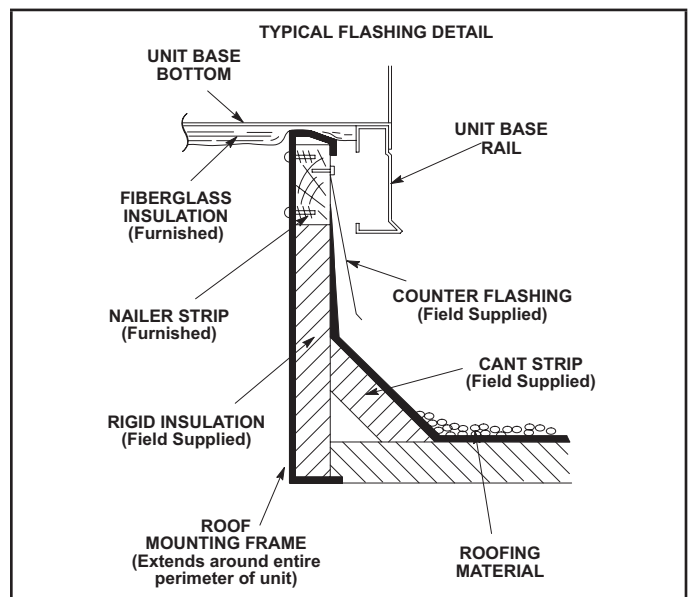

FIGURE 19

B-Transitions

Optional supply/return transitions T1TRAN10AN1 is available for use with the KHB 2, 2.5, 3, 4 and 5 ton units and T1TRAN20N-1 is available for the 6 ton units utilizing optional C1CURB roof mounting frames. Transition must be installed in the mounting frame before mounting the unit to the frame. Refer to the manufacturer's instructions included with the transition for detailed installation procedures.

C-Outdoor Air Dampers

C1DAMP11A-2 is available for all units. Both sets include the outdoor air hood. A motorized kit (K1DAMP21A-1) can be ordered separately for all unit sizes. The dampers may be manually or motor (M) operated to allow up to 25 percent outside air into the system at all times (FIGURE 20). Washable filter supplied with the outdoor air dampers can be cleaned with water and a mild detergent. It should be sprayed with Filter Handicoater when dry prior to reinstallation. Filter Handicoater is R.P. Products coating no. 418 and is available as Part No. P-8-5069.

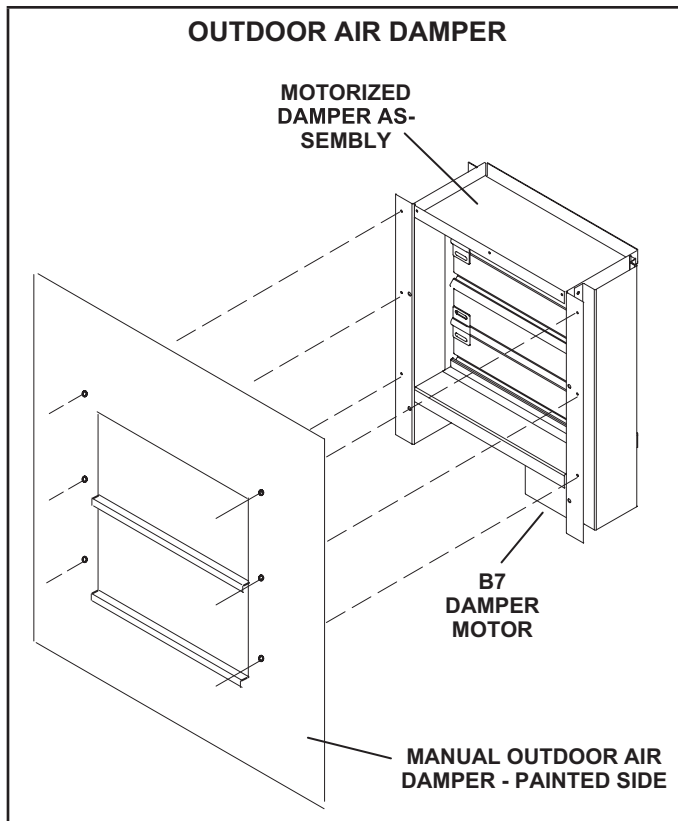

FIGURE 20

D-Supply and Return Diffusers (all units)

Optional flush mount diffuser/return FD9-65 and extended mount diffuser/return RTD9-65 available for use with all KHB units. Refer to manufacturer's instructions included with transition for detailed installation procedures.

E-Economizer - K1ECON30A-3 (standard) or

K1ECON32A-2 (high performance) Unit may contain an optional field or factory-installed economizer equipped with an A6 enthalpy control and an A7 outdoor enthalpy sensor. The modulating economizer opens fully to use outdoor air for free cooling when temperature is suitable and opens to minimum position during the occupied time period.

See economizer installation instruction for detail. The following is information on the K1ECON30A-3 standard economizer.

The A6 enthalpy control is located in the economizer access area. See FIGURE 21. The A7 enthalpy sensor is located on the division panel between horizontal supply and return air sections.

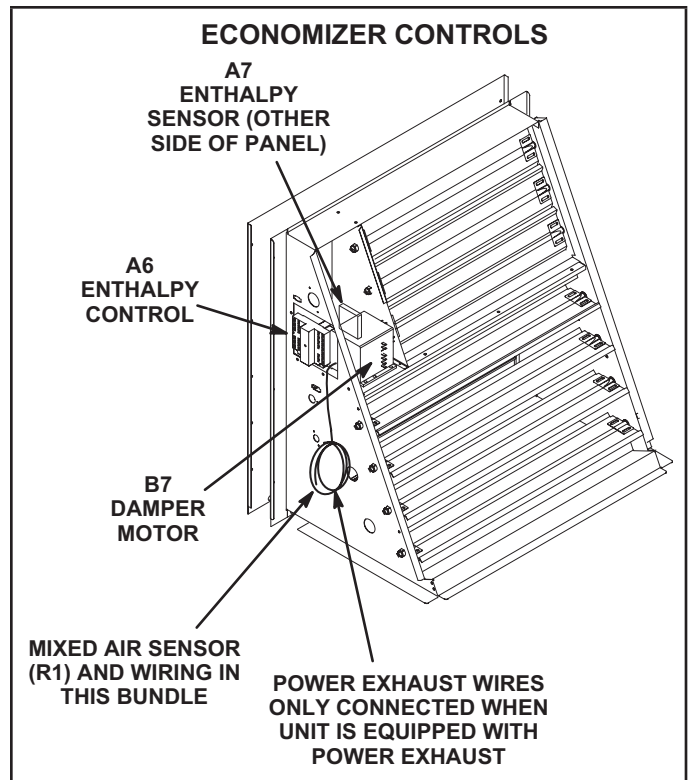

FIGURE 21

Optional Sensors

An optional differential sensor (A62) may be used with the A7 outdoor sensor to compare outdoor air enthalpy to return air enthalpy. When the outdoor air enthalpy is below the return air temperature, outdoor air is used for free cooling.

Mixed air sensor (R1) is used to modulate dampers to 55°F (13°C) discharge air.

An optional IAQ sensor (A63) may be used to lower operating costs by controlling outdoor air based on CO2 level or room occupancy (also called demand control ventilation or DCV). Damper minimum position can be set lower than traditional minimum air requirements; dampers open to traditional ventilation requirements when CO2 level reaches DCV (IAQ) setpoint.

Refer to instructions provided with sensors for installation.

A6 Enthalpy Control LED's

A steady green Free Cool LED indicates that outdoor air is suitable for free cooling.

When an optional IAQ sensor is installed, a steady green DCV LED indicates that the IAQ reading is higher than setpoint requiring more fresh air. See figure 22.

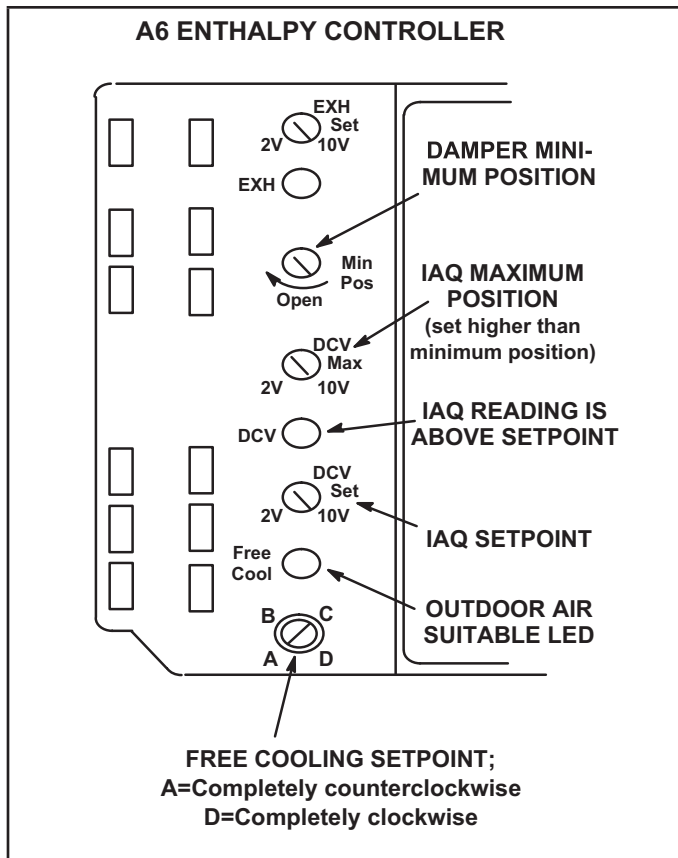

FIGURE 22

Free Cooling Setpoint

Outdoor air is considered suitable when temperature and humidity are less than the free cooling setpoints shown in TABLE 20. Setting A is recommended. See FIGURE 22. At setting A, free cooling will be energized when outdoor air is approximately 73°F (23°C) and 50% relative humidity. If indoor air is too warm or humid, lower the setpoint to B. At setting B, free cooling will be energized at 70°F (21°C) and 50% relative humidity.

When an optional A62 differential sensor is installed, turn A6 enthalpy control free cooling setpoint potentiometer completely clockwise to position “D”.

TABLE 20

ENTHALPY CONTROL SETPOINTS

Control Setting	Free Cooling Setpoint At 50% RH
A	73° F (23° C)
B	70° F (21° C)
C	67° F (19° C)
D	63° F (17° C)

Damper Minimum Position

NOTE - A jumper is factory-installed between TB1 A1 and A2 terminals to maintain occupied status (allowing minimum fresh air). When using an electronic thermostat or energy management system with an occupied/unoccupied feature, remove jumper.

- 1 - Set thermostat to occupied mode if the feature is available. Make sure jumper is in place between TB1 terminals R and OC if using a thermostat which does not have the feature.
- 2 - Rotate MIN POS SET potentiometer to approximate desired fresh air percentage.

Note - Damper minimum position can be set lower than traditional minimum air requirements when an IAQ sensor is specified. Dampers will open to DCV MAX setting (if CO2 is above setpoint) to meet traditional ventilation requirements.

- 3 - Measure outdoor air temperature. Mark the point on the bottom line of chart 1 and label the point “A” (40°F, 4°C shown).
- 4 - Measure return air temperature. Mark that point on the top line of chart 1 and label the point “B” (74°F, 23°C shown).
- 5 - Measure mixed air (outdoor and return air) temperature. Mark that point on the top line of chart 1 and label point “C” (70°F, 21°C shown).
- 6 - Draw a straight line between points A and B.
- 7 - Draw a vertical line through point C.
- 8 - Draw a horizontal line where the two lines meet. Read the percent of fresh air intake on the side.
- 9 - If fresh air percentage is less than desired, adjust MIN POS SET potentiometer higher. If fresh air percentage is more than desired, adjust MIN POS SET potentiometer lower. Repeat steps 3 through 8 until calculation reads desired fresh air percentage.

DCV Set and Max Settings

Adjust settings when an optional IAQ sensor is installed. The DCV SET potentiometer is factory-set at approximately 50% of the potentiometer range. Using a standard 1-2000ppm CO2 sensor, dampers will start to open when the IAQ sensor reads approximately 1000ppm. Adjust the DCV SET potentiometer to the approximate setting specified by the controls contractor. Refer to FIGURE 22.

The DCV MAX potentiometer is factory-set at approximately 50% of the potentiometer range or 6VDC. Dampers will open approximately half way when CO2 rises above setpoint. Adjust the DCV MAX potentiometer to the approximate setting specified by the controls contractor. Refer to FIGURE 22.

Note - DCV Max must be set higher than economizer minimum position setting for proper demand control ventilation.

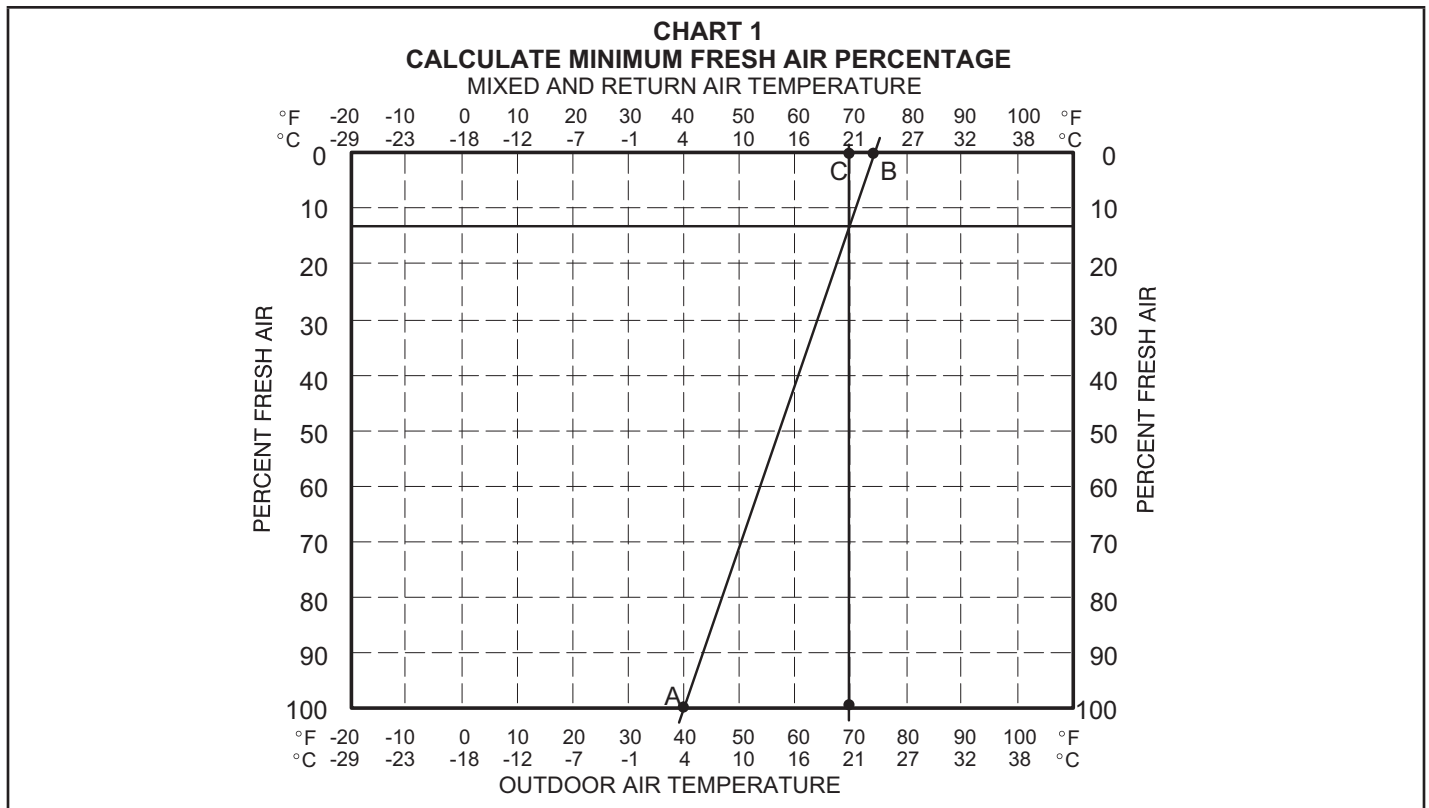

Economizer Operation

The occupied time period is determined by the thermostat or energy management system.

Outdoor Air Not Suitable:

During the unoccupied time period dampers are closed.

During the occupied time period a cooling demand will open dampers to minimum position and mechanical cooling functions normally.

During the occupied time period dampers will open to DCV MAX when IAQ reading is above setpoint (regardless of thermostat demand or outdoor air suitability).

Outdoor Air Suitable:

See TABLE 21 for economizer operation with a standard twostage thermostat.

During the occupied period, dampers will open to DCV MAX when IAQ reading is above setpoint (regardless of thermostat demand or outdoor air suitability). DCV MAX will NOT override damper full-open position. When an R1 mixed air sensor for modulating dampers is installed, DCV MAX may override damper free cooling position when occupancy is high and outdoor air temperatures are low. If R1 senses discharge air temperature below 45°F (7°C), dampers will move to minimum position until discharge air temperature rises to 48°F (9°C).

B-Outdoor Air Dampers

Optional manual and motorized outdoor air dampers provide fresh outdoor air. The motorized damper assembly opens to minimum position during the occupied time period and remains closed during the unoccupied period. Manual damper assembly is set at installation and remains in that position.

Set damper minimum position in the same manner as economizer minimum position. Adjust motorized damper position using the thumbwheel on the damper motor. See FIGURE 23. Manual damper fresh air intake percentage can be determined in the same manner.

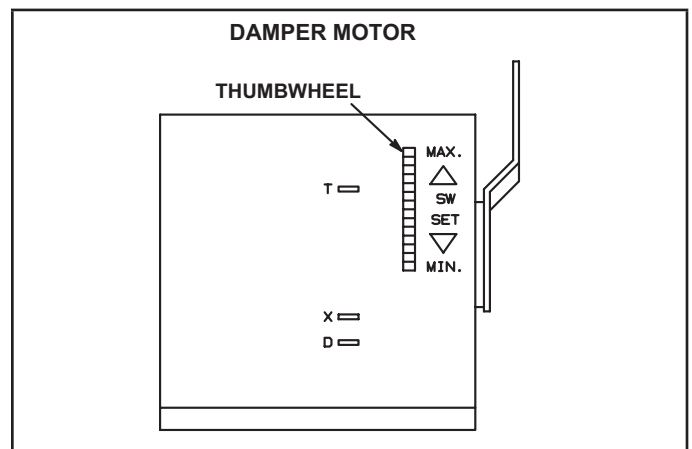

FIGURE 23

TABLE 21
ECONOMIZER OPERATION

OUTDOOR AIR IS SUITABLE FOR FREE COOLING -- FREE COOL LED "ON"

THERMOSTAT DEMAND	DAMPER POSITION		MECHANICAL COOLING
	UNOCCUPIED	OCCUPIED	
OFF	CLOSED	CLOSED	NO
G	CLOSED	MINIMUM	NO
Y1	OPEN*	OPEN*	NO
Y2	OPEN*	OPEN*	STAGE 1

*Dampers will modulate to maintain 55F (13C) supply air when an R1 mixed air sensor is installed

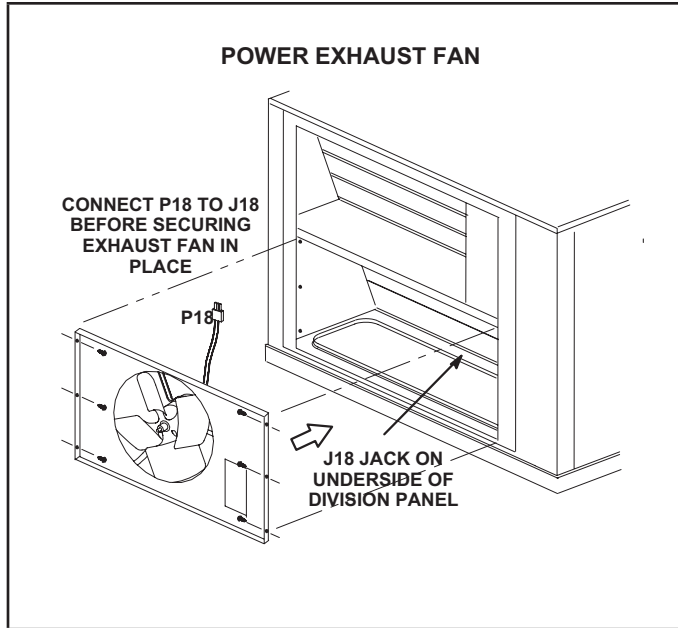

FIGURE 24

F-Power Exhaust Relay K65 (PED units)

Power exhaust relay K65 is a N.O. DPDT relay with a 24VAC coil. K65 is used in all KHB units equipped with the optional power exhaust dampers. K65 is energized by the economizer control panel (A6), after the economizer dampers reach 50% open (adjustable on control A6). When K65 closes, the exhaust fan B10 is energized.

G-Power Exhaust Fans

C1PWRE10A's are available for all units, and provide exhaust air pressure relief and also run when return air dampers are closed and supply air blowers are operating. See FIGURE 24 and installation instructions for more detail.

H-Dirty Filter Switch S27

The dirty filter switch senses static pressure increase indicating a dirty filter condition. The switch is N.O. and closes at 1" W.C. (248.6 Pa) The switch is mounted in the filter section on the left unit mullion.

I-Indoor Air Quality (CO2) Sensor A63

The indoor air quality sensor monitors CO2 levels and reports the levels to the economizer enthalpy control A6. Controller A6 adjusts the economizer dampers according to the CO2 levels. The sensor is mounted next to the indoor thermostat or in the return air duct. Refer to the indoor air quality sensor installation instructions for proper adjustment.

J-Drain Pan Overflow Switch S149 (optional)

The overflow switch is used to interrupt cooling operation when excessive condensate collects in the drain pan. The N.O. overflow switch is controlled by K220 and DL46 relays, located in the unit control panel. When the overflow switch closes, 24VAC power is interrupted and after a five-second delay unit compressors are de-energized. Once the condensate level drops below the set level, the switch will open. After a five-minute delay the compressor will be energized.

VII- WIRING DIAGRAMS / SEQUENCE OF OPERATION

KHB024-060S P Voltage

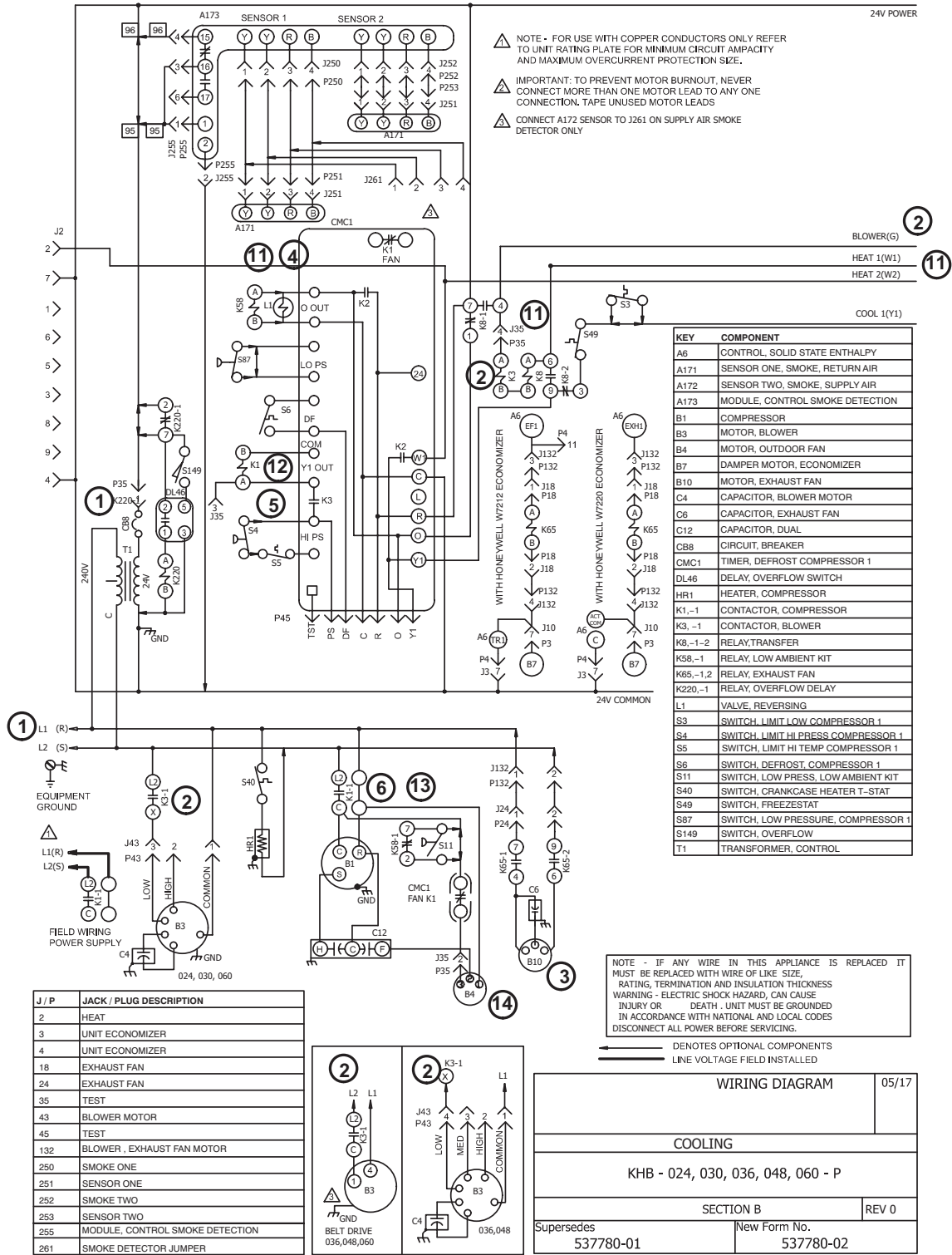

J / P	JACK / PLUG DESCRIPTION
2	HEAT
3	UNIT ECONOMIZER
4	UNIT ECONOMIZER
18	EXHAUST FAN
24	EXHAUST FAN
35	TEST
43	BLOWER MOTOR
45	TEST
132	BLOWER , EXHAUST FAN MOTOR
250	SMOKE ONE
251	SENSOR ONE
252	SMOKE TWO
253	SENSOR TWO
255	MODULE, CONTROL SMOKE DETECTION
261	SMOKE DETECTOR JUMPER

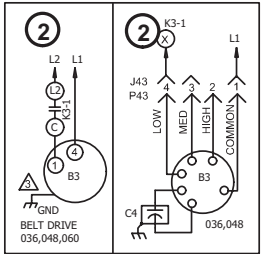

WIRING DIAGRAM 05/17

COOLING

KHB - 024, 030, 036, 048, 060 - P

SECTION B REV 0

Supersedes 537780-01 New Form No. 537780-02

KHB036, 048, 060, 072, 074S G,J, M,Y Voltage

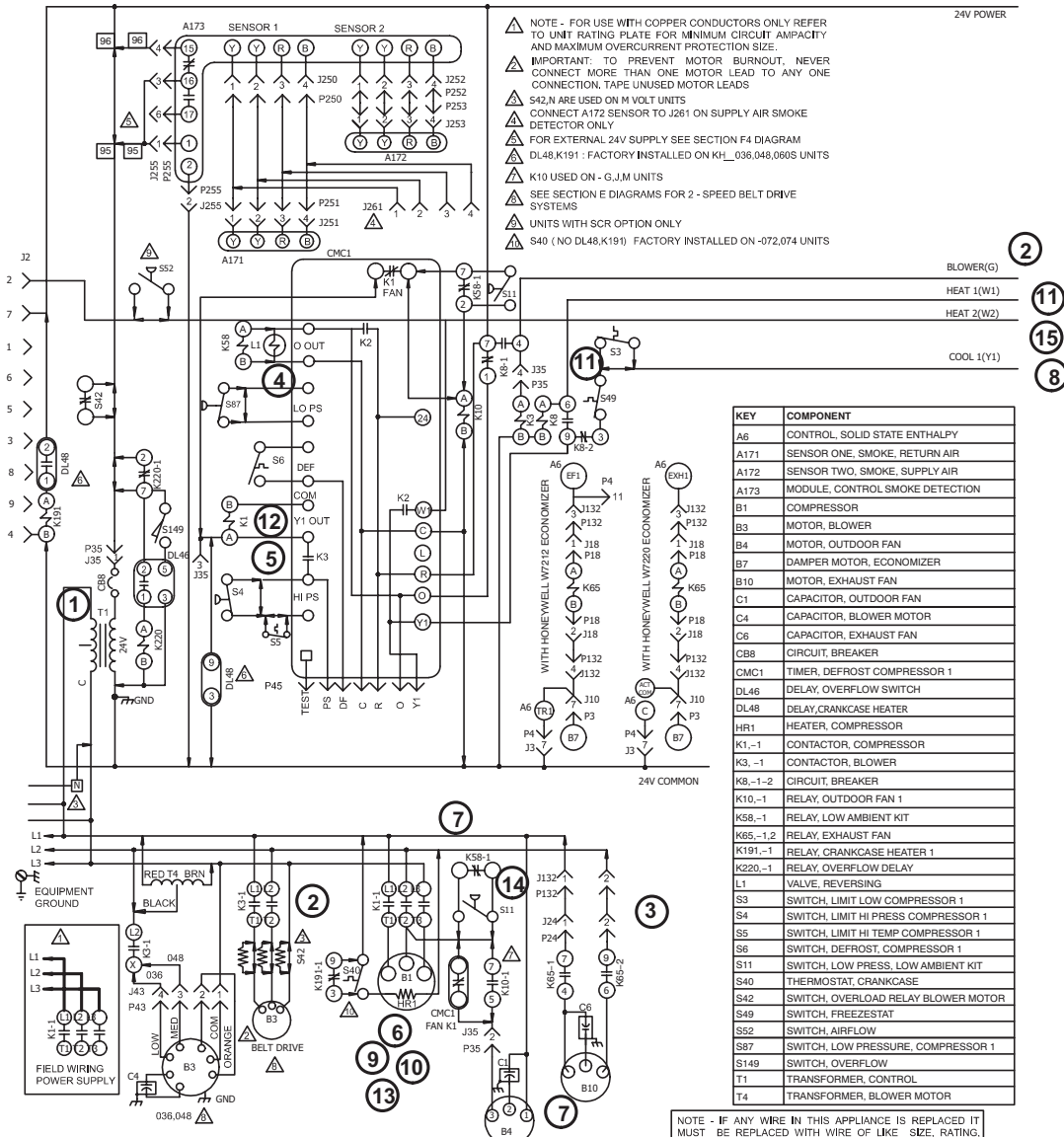

NOTE - FOR USE WITH COPPER CONDUCTORS ONLY REFER TO UNIT RATING PLATE FOR MINIMUM CIRCUIT AMPACITY AND MAXIMUM OVERCURRENT PROTECTION SIZE.
 IMPORTANT TO PREVENT MOTOR BURNOUT, NEVER CONNECT MORE THAN ONE MOTOR LEAD TO ANY ONE CONNECTION, TAPE UNUSED MOTOR LEADS
 S42,N ARE USED ON M VOLT UNITS
 CONNECT A172 SENSOR TO J261 ON SUPPLY AIR SMOKE DETECTOR ONLY
 FOR EXTERNAL 24V SUPPLY SEE SECTION F4 DIAGRAM
 DL48,K191 : FACTORY INSTALLED ON KH_036,048,060S UNITS
 K10 USED ON - G,J,M UNITS
 SEE SECTION E DIAGRAMS FOR 2 - SPEED BELT DRIVE SYSTEMS
 UNITS WITH SCR OPTION ONLY
 S40 (NO DL48,K191) FACTORY INSTALLED ON -072,074 UNITS

KEY	COMPONENT
A6	CONTROL, SOLID STATE ENTHALPY
A171	SENSOR ONE, SMOKE, RETURN AIR
A172	SENSOR TWO, SMOKE, SUPPLY AIR
A173	MODULE, CONTROL SMOKE DETECTION
B1	COMPRESSOR
B3	MOTOR, BLOWER
B4	MOTOR, OUTDOOR FAN
B7	DAMPER MOTOR, ECONOMIZER
B10	MOTOR, EXHAUST FAN
C1	CAPACITOR, OUTDOOR FAN
C4	CAPACITOR, BLOWER MOTOR
C6	CAPACITOR, EXHAUST FAN
CB8	CIRCUIT, BREAKER
CMC1	TIMER, DEFROST COMPRESSOR 1
DL46	DELAY, OVERFLOW SWITCH
DL48	DELAY, CRANKCASE HEATER
HR1	HEATER, COMPRESSOR
K1,-1	CONTACTOR, COMPRESSOR
K3,-1	CONTACTOR, BLOWER
K8,-1-2	CIRCUIT, BREAKER
K10,-1	RELAY, OUTDOOR FAN 1
K58,-1	RELAY, LOW AMBIENT KIT
K65,-1,2	RELAY, EXHAUST FAN
K191,-1	RELAY, CRANKCASE HEATER 1
K220,-1	RELAY, OVERFLOW DELAY
L1	VALVE, REVERSING
S3	SWITCH, LIMIT LOW COMPRESSOR 1
S4	SWITCH, LIMIT HI PRESS COMPRESSOR 1
S5	SWITCH, LIMIT HI TEMP COMPRESSOR 1
S6	SWITCH, DEFROST, COMPRESSOR 1
S11	SWITCH, LOW PRESS, LOW AMBIENT KIT
S40	THERMOSTAT, CRANKCASE
S42	SWITCH, OVERLOAD RELAY BLOWER MOTOR
S49	SWITCH, FREEZESTAT
S52	SWITCH, AIRFLOW
S87	SWITCH, LOW PRESSURE, COMPRESSOR 1
S149	SWITCH, OVERFLOW
T1	TRANSFORMER, CONTROL
T4	TRANSFORMER, BLOWER MOTOR

NOTE - IF ANY WIRE IN THIS APPLIANCE IS REPLACED IT MUST BE REPLACED WITH WIRE OF LIKE SIZE, RATING, TERMINATION AND INSULATION THICKNESS
 WARNING - ELECTRIC SHOCK HAZARD, CAN CAUSE INJURY OR DEATH - UNIT MUST BE GROUNDED IN ACCORDANCE WITH NATIONAL AND LOCAL CODES
 DISCONNECT ALL POWER BEFORE SERVICING.

— DENOTES OPTIONAL COMPONENTS
 — LINE VOLTAGE FIELD INSTALLED

J / P	JACK / PLUG DESCRIPTION
2	HEAT
3	UNIT ECONOMIZER
10	ECONOMIZER
18	EXHAUST FAN
24	EXHAUST FAN
35	TEST
43	BLOWER MOTOR
45	INPUT
132	BLOWER, EXHAUST FAN MOTOR
250	SMOKE ONE
251	SENSOR ONE
252	SMOKE TWO
253	SENSOR TWO
255	MODULE, CONTROL SMOKE DETECTION
261	SMOKE DETECTOR JUMPER

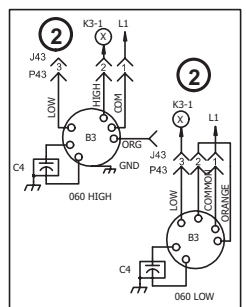

WIRING DIAGRAM		03/18
COOLING		
KHA,B - 036, 048, 060, 072, 074 - G, J,M,Y		
SECTION B		REV 1
Supersedes 537779-01	New Form No. 537779-02	

SEQUENCE OF OPERATION KHB024/074 Standard Efficiency Units

Power:

- 1 - Line voltage from unit disconnect energizes transformer T1. T1 provides 24VAC power to terminal strip TB1 found in the control box. TB1 provides 24VAC to the unit cooling, heating and blower controls.

Blower Operation: (See next page for KHB-074)

- 2 - Indoor thermostat terminal "G" energizes contactor K3. K3 closes, energizing blower B3.

Economizer Operation:

- 3 - The EXH (power exhaust set point) found on the face of A6, is factory set at approximate 50% of the dial range. Economizer control module A6 receives a demand and opens outside dampers 50%. Power exhaust fan relay K65 is energized 30 seconds after dampers are 50% open. K65-1 and K65-2 close, energizing power exhaust fan B10.

Cooling Demand

Cooling demand energizes Y1 and G in the thermostat. G energizes blower (see step 2.)

- 4 - Indoor thermostat COOLING mode energizes reversing valve L1.
- 5 - CMC1 proves optional N.C. high pressure switch S4 to energize compressor contactor K1.
- 6 - K1 closes energizing compressor B1.
- 7 - **P and Y Voltage**

Line voltage is routed through optional N.O. low ambient pressure switch S11 and optional low ambient kit K58 to energize outdoor fan B4.

G, J and M Voltage

24VAC passes through optional N.O. low pressure switch S11 and optional low ambient kit K58 to energize outdoor fan relay K10. N.O. contacts K10-1 close energizing outdoor fan B4 .

KHB-074 Two-Stage Units

- 8 - First-stage cooling demand Y1 and G is energized by the thermostat. G energizes blower.
- 9 - Following from step 7 K1 energizes compressor B1, outdoor fan B4 and blower B3 on low speed.
- 10 - Second-stage cooling demand Y2 energizes compressor B1, outdoor fan B3 and blower B4 on high speed.

First Stage Heat

NOTE: *On heating demand after unit has been in cooling mode, indoor thermostat in HEATING mode will deenergize reversing valve L1.*

- 11 - Heating demand energizes W1 in the thermostat. Relay K8 is energized. N.C. K8-1 opens, de-energizing reversing valve L1.
- 12 - CMC1 proves optional N.C. high pressure switches S4. Compressor contactor K1 is energized.
- 13 - K1 closes energizing compressor B1.
- 14 - **P and Y Voltage**

Line voltage from CMC1 is routed through optional N.C. low ambient switch S11 to energize outdoor fan B4.

G, J and M Voltage

24VAC passes through optional N.O. low pressure switch and optional low ambient switch K58 to energize outdoor fan relay K10. K10-1 closes energizing outdoor fan B4.

Second Stage Heat (electric heat):

- 15 - Second stage heat demand energizes W2 in the thermostat.

See sequence of operation for electric heat.

DEFROST MODE:

- 16 - When a defrost cycle is initiated, the control energizes the reversing valve solenoid and turns off the condenser fan. The control will also put 24VAC on the "W1" (auxiliary heat) line. The unit will stay in this mode until either the defrost thermostat (S6) temperature is above the termination temperature of 70°, the defrost time of 14 minutes has been completed, or the room thermostat demand cycle has been satisfied. If the room thermostat demand cycle terminates the cycle, the defrost cycle will be held until the next room thermostat demand cycle. If the defrost thermostat (S6) temperature is still below the termination temperature, the control will continue the defrost cycle until the cycle is terminated in one of the methods mentioned above.

KHB024H, 036H, 048H, 060H G,J, P, Y Voltage Direct Drive

24V POWER

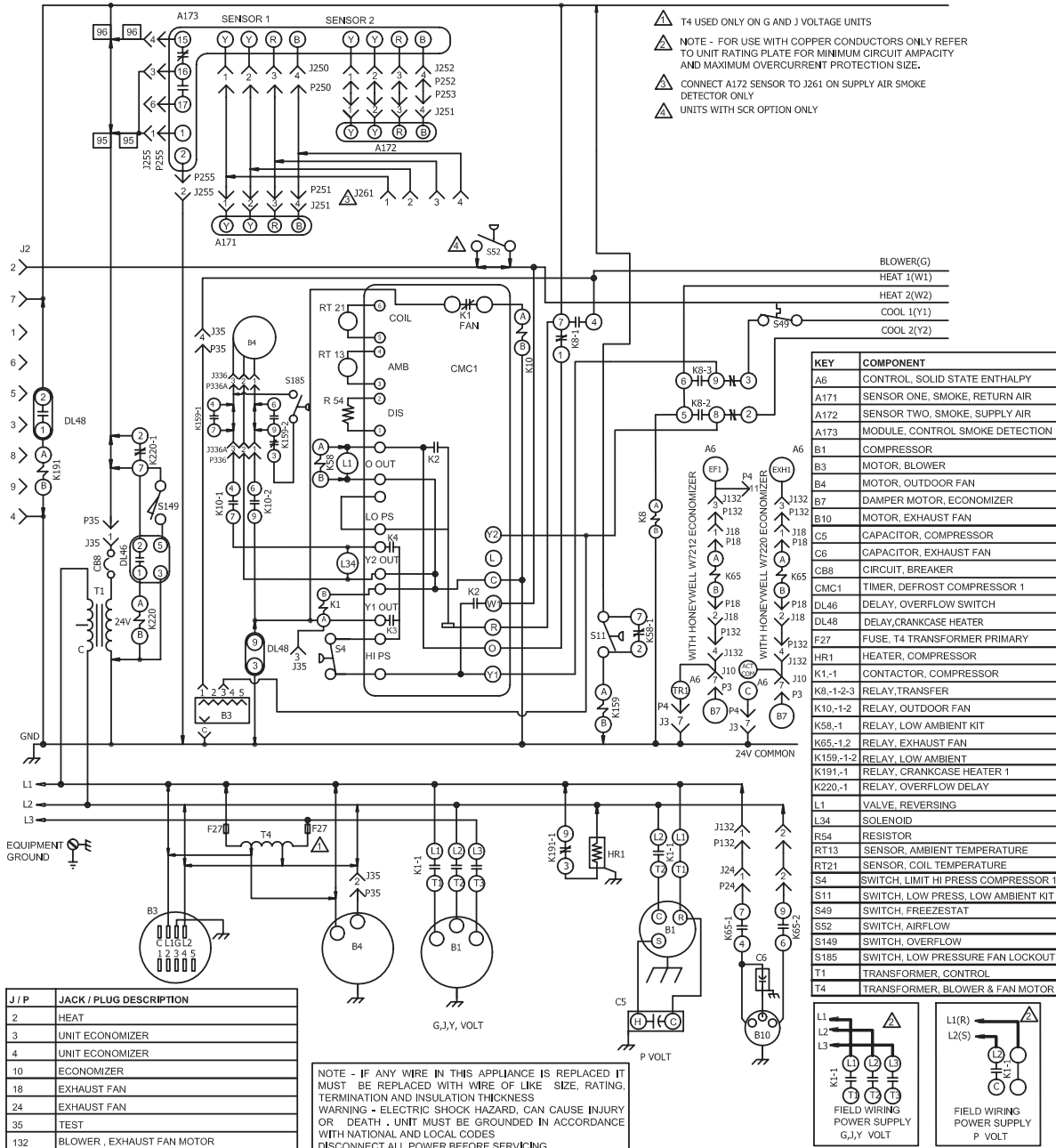

- ⚠ T4 USED ONLY ON G AND J VOLTAGE UNITS
- ⚠ NOTE - FOR USE WITH COPPER CONDUCTORS ONLY REFER TO UNIT RATING PLATE FOR MINIMUM CIRCUIT AMPACITY AND MAXIMUM OVERCURRENT PROTECTION SIZE.
- ⚠ CONNECT A172 SENSOR TO J261 ON SUPPLY AIR SMOKE DETECTOR ONLY
- ⚠ UNITS WITH SCR OPTION ONLY

- BLOWER(G)
- HEAT 1(W1)
- HEAT 2(W2)
- COOL 1(Y1)
- COOL 2(Y2)

KEY	COMPONENT
A6	CONTROL, SOLID STATE ENTHALPY
A171	SENSOR ONE, SMOKE, RETURN AIR
A172	SENSOR TWO, SMOKE, SUPPLY AIR
A173	MODULE, CONTROL SMOKE DETECTION
B1	COMPRESSOR
B3	MOTOR, BLOWER
B4	MOTOR, OUTDOOR FAN
B7	DAMPER MOTOR, ECONOMIZER
B10	MOTOR, EXHAUST FAN
C5	CAPACITOR, COMPRESSOR
C6	CAPACITOR, EXHAUST FAN
CB8	CIRCUIT, BREAKER
CMC1	TIMER, DEFROST COMPRESSOR 1
DL46	DELAY, OVERFLOW SWITCH
DL48	DELAY, CRANKCASE HEATER
F27	FUSE, T4 TRANSFORMER PRIMARY
HR1	HEATER, COMPRESSOR
K1-1	CONTACTOR, COMPRESSOR
K8-1-2-3	RELAY, TRANSFER
K10-1-2	RELAY, OUTDOOR FAN
K58-1	RELAY, LOW AMBIENT KIT
K65-1,2	RELAY, EXHAUST FAN
K159-1-2	RELAY, LOW AMBIENT
K191-1	RELAY, CRANKCASE HEATER 1
K220-1	RELAY, OVERFLOW DELAY
L1	VALVE, REVERSING
L34	SOLENOID
R54	RESISTOR
RT13	SENSOR, AMBIENT TEMPERATURE
RT21	SENSOR, COIL TEMPERATURE
S4	SWITCH, LIMIT HI PRESS COMPRESSOR 1
S11	SWITCH, LOW PRESS, LOW AMBIENT KIT
S49	SWITCH, FREEZE/STAT
S52	SWITCH, AIRFLOW
S149	SWITCH, OVERFLOW
S185	SWITCH, LOW PRESSURE FAN LOCKOUT
T1	TRANSFORMER, CONTROL
T4	TRANSFORMER, BLOWER & FAN MOTOR

J / P	JACK / PLUG DESCRIPTION
2	HEAT
3	UNIT ECONOMIZER
4	UNIT ECONOMIZER
10	ECONOMIZER
18	EXHAUST FAN
24	EXHAUST FAN
35	TEST
132	BLOWER, EXHAUST FAN MOTOR
250	SMOKE ONE
251	SENSOR ONE
252	SMOKE TWO
253	SENSOR TWO
255	MODULE, CONTROL SMOKE DETECTION
261	SMOKE DETECTOR JUMPER
336.336A	OUTDOOR FAN CONTROL, B4

NOTE - IF ANY WIRE IN THIS APPLIANCE IS REPLACED IT MUST BE REPLACED WITH WIRE OF LIKE SIZE, RATING, TERMINATION AND INSULATION THICKNESS. WARNING - ELECTRIC SHOCK HAZARD, CAN CAUSE INJURY OR DEATH. UNIT MUST BE GROUNDED IN ACCORDANCE WITH NATIONAL AND LOCAL CODES. DISCONNECT ALL POWER BEFORE SERVICING.

— DENOTES OPTIONAL COMPONENTS
 — LINE VOLTAGE FIELD INSTALLED

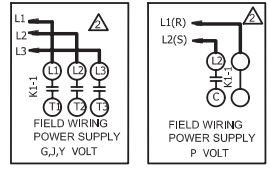

09/16

WIRING DIAGRAM

537855-01

09/16

COOLING

KHB - 024H, 036H, 048H, 060H - G,J,P,Y

DIRECT DRIVE

Supersedes
New Form No. 537855-01

KHB036H, 048H, 060H G, J, M, Y Voltage Belt Drive

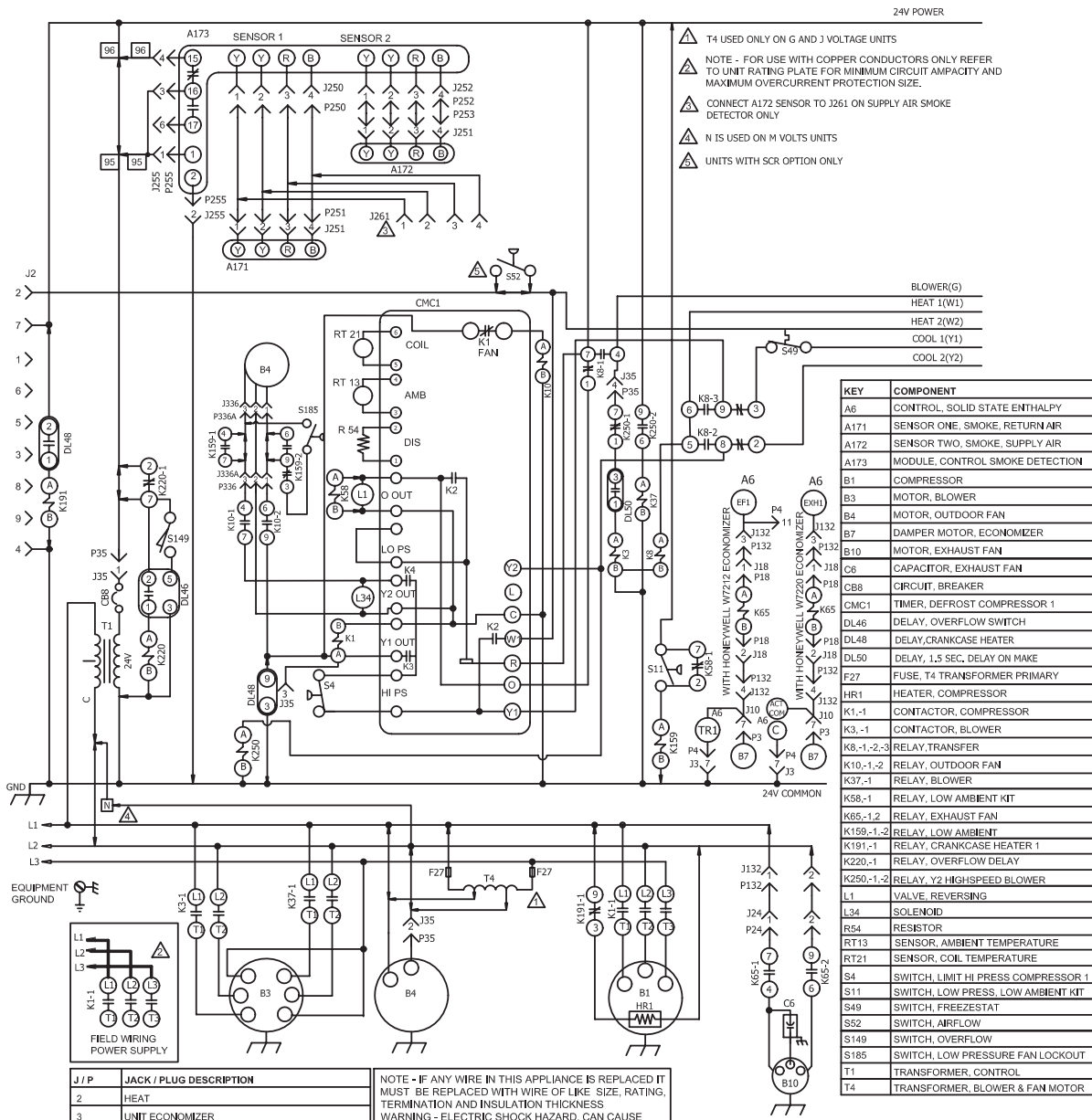

J / P	JACK / PLUG DESCRIPTION
2	HEAT
3	UNIT ECONOMIZER
4	UNIT ECONOMIZER
10	ECONOMIZER
18	EXHAUST FAN
24	EXHAUST FAN
35	TEST
132	BLOWER, EXHAUST FAN MOTOR
250	SMOKE ONE
251	SENSOR ONE
252	SMOKE TWO
253	SENSOR TWO
255	MODULE, CONTROL SMOKE DETECTION
261	SMOKE DETECTOR JUMPER
336.336A	OUTDOOR FAN CONTROL, B4

NOTE - IF ANY WIRE IN THIS APPLIANCE IS REPLACED IT MUST BE REPLACED WITH WIRE OF LIKE SIZE, RATING, TERMINATION AND INSULATION THICKNESS
 WARNING - ELECTRIC SHOCK HAZARD, CAN CAUSE INJURY OR DEATH, UNIT MUST BE GROUNDED IN ACCORDANCE WITH NATIONAL AND LOCAL CODES DISCONNECT ALL POWER BEFORE SERVICING.

← DENOTES OPTIONAL COMPONENTS
 — LINE VOLTAGE FIELD INSTALLED

KEY	COMPONENT
A6	CONTROL, SOLID STATE ENTHALPY
A171	SENSOR ONE, SMOKE, RETURN AIR
A172	SENSOR TWO, SMOKE, SUPPLY AIR
A173	MODULE, CONTROL SMOKE DETECTION
B1	COMPRESSOR
B3	MOTOR, BLOWER
B4	MOTOR, OUTDOOR FAN
B7	DAMPER MOTOR, ECONOMIZER
B10	MOTOR, EXHAUST FAN
C6	CAPACITOR, EXHAUST FAN
CB8	CIRCUIT, BREAKER
CMC1	TIMER, DEFROST COMPRESSOR 1
DL46	DELAY, OVERFLOW SWITCH
DL48	DELAY, CRANKCASE HEATER
DL50	DELAY, 1.5 SEC, DELAY ON MAKE
F27	FUSE, T4 TRANSFORMER PRIMARY
HR1	HEATER, COMPRESSOR
K1,-1	CONTACTOR, COMPRESSOR
K3,-1	CONTACTOR, BLOWER
K8,-1,-2,-3	RELAY, TRANSFER
K10,-1,-2	RELAY, OUTDOOR FAN
K37,-1	RELAY, BLOWER
K58,-1	RELAY, LOW AMBIENT KIT
K65,-1,2	RELAY, EXHAUST FAN
K159,-1,-2	RELAY, LOW AMBIENT
K191,-1	RELAY, CRANKCASE HEATER 1
K220,-1	RELAY, OVERFLOW DELAY
K250,-1,-2	RELAY, Y2 HIGH SPEED BLOWER
L1	VALVE, REVERSING
L34	SOLENOID
R54	RESISTOR
RT13	SENSOR, AMBIENT TEMPERATURE
RT21	SENSOR, COIL TEMPERATURE
S4	SWITCH, LIMIT HI PRESS COMPRESSOR 1
S11	SWITCH, LOW PRESS, LOW AMBIENT KIT
S49	SWITCH, FREEZESTAT
S52	SWITCH, AIRFLOW
S149	SWITCH, OVERFLOW
S185	SWITCH, LOW PRESSURE FAN LOCKOUT
T1	TRANSFORMER, CONTROL
T4	TRANSFORMER, BLOWER & FAN MOTOR

09/16
WIRING DIAGRAM
09/16

537856-01

COOLING

KHB - 036H, 048H, 060H - G, J, M, Y
BELT DRIVE

SECTION B

Supersedes: New Form No. 537856-01

SEQUENCE OF OPERATION KHB024/060 High Efficiency Units

Power:

- 1 - Line voltage from unit disconnect energizes transformer T1. T1 provides 24VAC power to terminal strip TB1 found in the control box. TB1 provides 24VAC to the unit cooling, heating and blower controls.

Blower Operation:

- 2 - Belt drive motors: Indoor thermostat terminal "G" energizes contactor K3. K3 closes, energizing blower B3. Direct drive motors: Indoor thermostat terminal "G" energizes blower B3 directly.

Economizer Operation:

- 3 - The EXH (power exhaust set point) found on the face of A6, is factory set at approximate 50% of the dial range. Economizer control module A6 receives a demand and opens outside dampers 50%. Power exhaust fan relay K65 is energized 30 seconds after dampers are 50% open. K65-1 and K65-2 close, energizing power exhaust fan B10.

Cooling Demand

First Stage Cooling demand energizes Y1 and G in the thermostat. G energizes blower (see step 2.)

- 4 - Indoor thermostat COOLING mode energizes reversing valve L1.
- 5 - CMC1 proves optional N.C. high pressure switch S4 to energize compressor contactor K1.
- 6 - K1 closes energizing compressor B1.
- 7 - Thermostat Y2 energizes blower B3 on high speed. CMC1 Y2 energizes compressor solenoid L34, transferring 24VAC to K10. K10-7 and K10-9 close energizing condenser fan B4 on high speed.
- 8 - Low ambient option: cooling mode energizes K58, when liquid pressure rises to 300±10 psig, S185 closes, 24VAC passes through the N.C. K159-2 contacts energizing condenser fan at extra low speed. (Y1, or Y2 demand).

When liquid pressure rises to 450±10 psig, S11 closes, energizing K159. 24VAC passes through K159-9 to condenser fan (Y1), and to K159-7 (Y2). Condenser fan runs at low speed with Y1 demand, and runs at high speed with demand Y2.

First Stage Heat -

NOTE: On heating demand after unit has been in cooling mode, indoor thermostat in HEATING mode will deenergize reversing valve L1.

- 9 - Heating demand energizes W1 in the thermostat. Relay K8 is energized. N.C. K8-1 opens, de-energizing reversing valve L1. K8-2 energizes blower and enables compressor for high speed. K8-3 energizes compressor.

- 10 - CMC1 proves optional N.C. high pressure switches S4. Compressor contactor K1 and outdoor fan relay K10 is energized.

- 11 - CMC1 Y2 OUT energizes compressor solenoid L34 for high speed

- 12 - CMC1 energizes condenser fan relay K10 (with "K1 fan" closes). 24VAC passes through the N.O. K10 contacts, from K10-9 to J336-3, from K10-7 to J336-1. condenser fan runs high speed.

Second Stage Heat - (Electric Heat)

- 13 - Second stage heat demand energizes W2 in the thermostat.

- 14 - See sequence of operation for electric heat.

DEFROST OPERATION:

- 15 - The need for a defrost cycle while in Demand Defrost operation is determined by one of two factors:

Time or Frost Detection.

Should six hours of compressor run time elapse without a defrost cycle and the coil temperature is below the frost accumulation temperature, a defrost will be initiated. If this defrost is terminated on time rather than temperature, the controller shall establish a new clear coil temperature condition. If the defrost is terminated on temperature the unit will continue with demand mode operations. The compressor run time will be reset when the defrost cycle is complete. The control shall be capable of detecting frost accumulation on the outdoor coil and initiate a defrost cycle when the initial clear coil ΔT has been increased by 2.3F° (IE – Target ΔT = clear coil ΔT + 2.3F°). In addition, the Target ΔT , once established, is adjusted as the ambient temperature changes to compensate for expected changes in the coil temperature. For every 8F° increase in ambient temperature, the target ΔT value is increased by 1F°; and, for every 8F° decrease in ambient temperature, the target ΔT value is decreased by 1F°.

- 16 - When operating in the defrost mode, the control will activate the compressor contactor, reversing valve, and auxiliary heat outputs (W1). The condenser fan relay contacts will be open, de-energizing the fan motor. The accumulated defrost time is monitored while in the defrost mode and compressor stays energized.

When a defrost cycle has been initiated, if the W1 thermostat input is removed, the current defrost cycle will be suspended, but the accumulated defrost time is frozen, and the control will resume defrost operation at the start of the next heating cycle (W1 active and coil temperature is below 35°F) without delay. The accumulated defrost time resumes when the compressor output is re-energized.

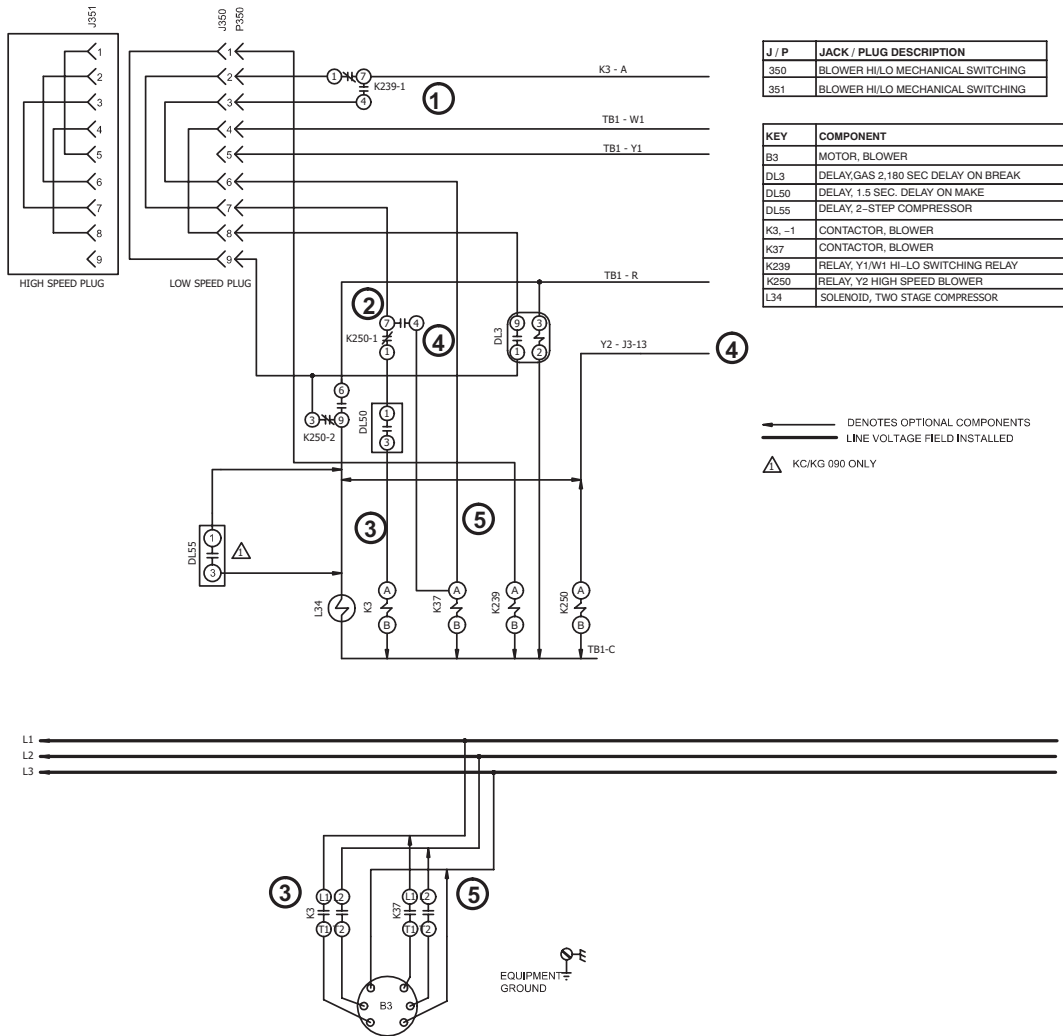

KHB-074 Two-Stage Units

- First-stage cooling demand Y1** and G is energized by the thermostat. G energizes blower.
- Relay K239 directs voltage through relay K250 to energize contactor K3.
- Blower contactor K3 energizes blower B3 on low speed.
- Second-stage cooling demand Y2** energizes relay K250 to redirect voltage to contactor K37
- Contactor K37 energizes blower B3 on high speed.

WIRING DIAGRAM		03/18
COOLING		
2 SPEED A - BOX AND A+ - BOX - G,J,M,Y		
SECTION E		REV. 1
Supersedes 537822-01	New Form No. 537822-02	

ELECTRONIC OR ELECTROMECHANICAL THERMOSTAT

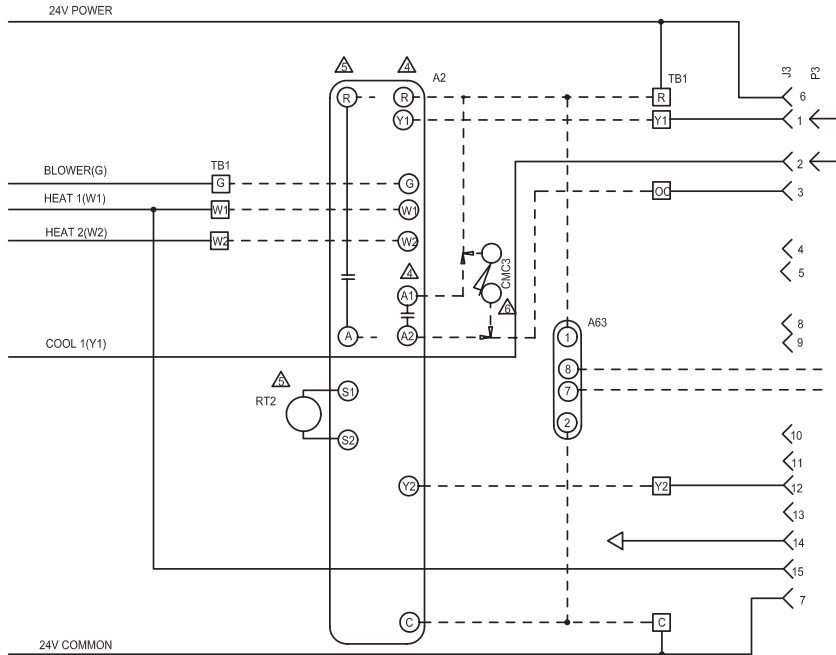

KEY	COMPONENT
A2	SENSOR-ELECTRONIC
A63	SENSOR-CO2
CMC3	CLOCK-TIME
J3	JACK-UNIT ECONOMIZER
P3	PLUG-LESS ECONOMIZER
RT2	SENSOR-REMOTE THERMOSTAT
TB1	TERMINAL STRIP-CLASS II VOLTAGE

- △ THERMOSTAT SUPPLIED BY USER
- △ REMOVE P3 WHEN ECONOMIZER IS USED
- △ J3 MAXIMUM LOAD 20VA 24VAC CLASS II
- △ T7300 THERMOSTAT
- △ T88220 TOUCHSCREEN THERMOSTAT
- △ TIME CLOCK CONTACTS (OPT) CLOSED OCCUPIED

DESIGNATES OPTIONAL WIRING
 CLASS II FIELD WIRING

06/13	WIRING DIAGRAM	06/13
537637-01		
ACCESSORIES		
ELECTRONIC OR ELECTROMECHANICAL THERMOSTAT FOR K SERIES		
SECTION C		REV 0
Supersedes	New Form No.	
537483-01	537637-01	

POWER:

- Terminal strip TB1 found in the main control box supplies thermostat components with 24VAC.

OPERATION:

- TB1 receives data from the electronic thermostat A2 (Y1, Y2, W1, W2, G) and energizes the appropriate components for heat or cool demand.

ECONOMIZER

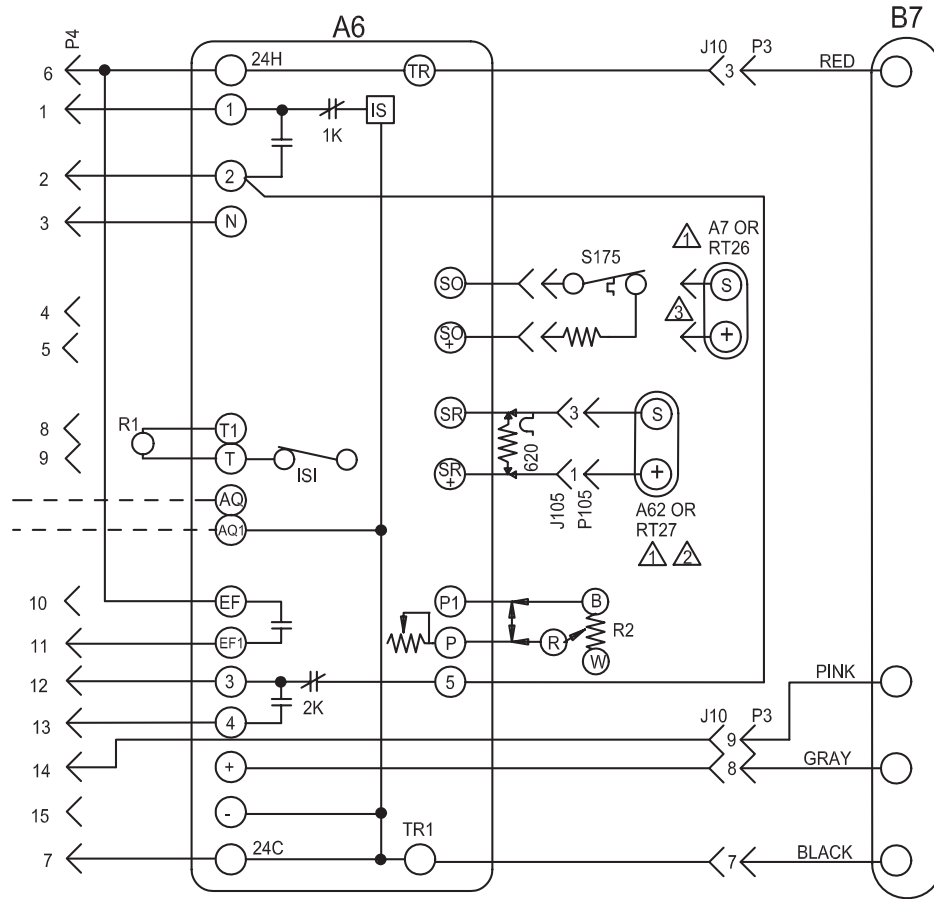

KEY	COMPONENT
A6	CONTROL-SOLID STATE ENTHALPY
A7	SENSOR-SOLID STATE ENTHALPY
A62	SENSOR-ENTHALPY, INDOOR
B7	MOTOR-DAMPER, ECONOMIZER
J10	JACK, ECONOMIZER
P3	PLUG, ECONOMIZER
P4	PLUG-ECONOMIZER
R1	SENSOR-MIXED AIR OR SUPPLY AIR
R2	POT-MINIMUM POSITION
RT26	SENSOR-OUTDOOR AIR TEMP
RT27	SENSOR-INDOOR AIR TEMP
S175	THERMOSTAT, SENSIBLE AIR

▲ RT26 AND RT27, TEMPERATURE SENSORS MAY BE USED INSTEAD OF A7 AND A62 ENTHALPY SENSORS

▲ A62 ENTHALPY SENSOR OR RT27 USED FOR DIFFERENTIAL SENSING

▲ OPTIONAL OUTDOOR AIR THERMOSTAT TO REPLACE RT26 SENSIBLE SENSOR

————— DESIGNATES OPTIONAL WIRING
CLASS II FIELD WIRING

08/15		537620-01	08/15
ACCESSORIES			
ECONOMIZER LANDMARK A-BOX			
SECTION D1			REV 1
Supersedes Form No. 537484-01		New Form No. 537620-01	

T1EH-7.5, 10, 15, 22.5 kW P VOLTAGE

24V POWER

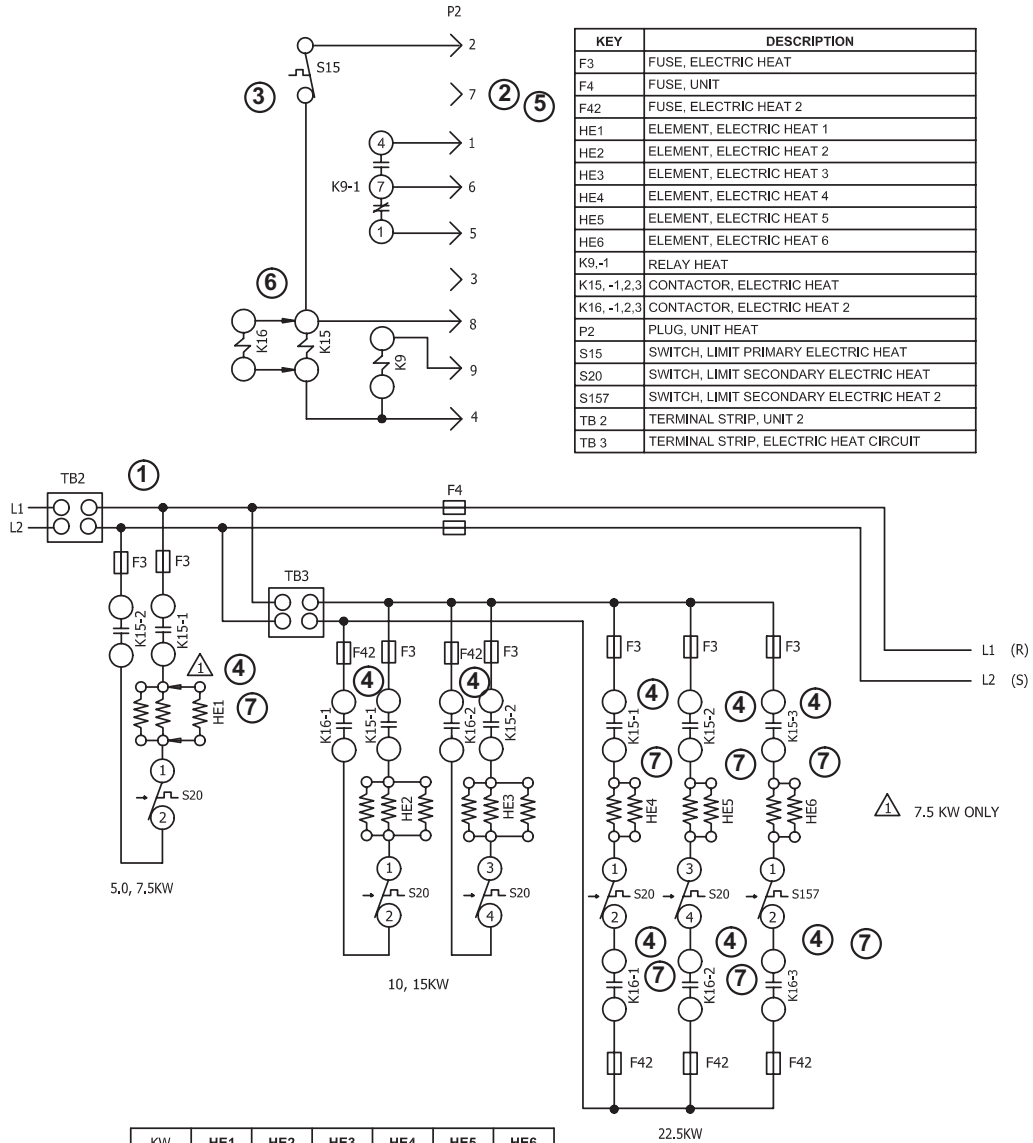

	KW	HE1	HE2	HE3	HE4	HE5	HE6
024	5.0	5.0					
030	10.0		5.0	5.0			
036	7.5	7.5					
048	15		7.5	7.5			
060	22.5				7.5	7.5	7.5

← DENOTES OPTIONAL COMPONENTS

09/14	WIRING DIAGRAM	09/14
537783-01		
HEATING - ELECTRIC		
T1EH - 7.5, 10, 15, 22.5 - P		
K1EH - 5.0 - P, A - BOX		
SECTION A		REV 0
Supersedes	New Form No.	
	537783-01	

T1EHA-7.5, 15, 22.5kW Y VOLT-

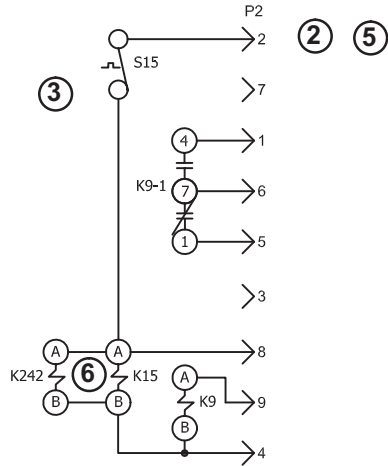

DESCRIPTION	
KEY	DESCRIPTION
F3	FUSE, ELECTRIC HEAT
F4	FUSE, UNIT
F42	FUSE, ELECTRIC HEAT 2
HE -1	ELEMENT, ELECTRIC HEAT 1
HE -2	ELEMENT, ELECTRIC HEAT 2
HE -3	ELEMENT, ELECTRIC HEAT 3
K9,-1	RELAY - HEAT
K15,-1	CONTACTOR, ELECTRIC HEAT 1
K242,-1	CONTACTOR, ELECTRIC HEAT 1
P2	PLUG, UNIT HEAT
S15	SWITCH, LIMIT PRIMARY ELECTRIC HEAT
S20	SWITCH, LIMIT SECONDARY ELECTRIC HEAT 1
S157	SWITCH, LIMIT SECONDARY ELECTRIC HEAT 2
TB2	TERMINAL STRIP, UNIT
TB3	TERMINAL STRIP - ELECTRIC HEAT , CIRC 1

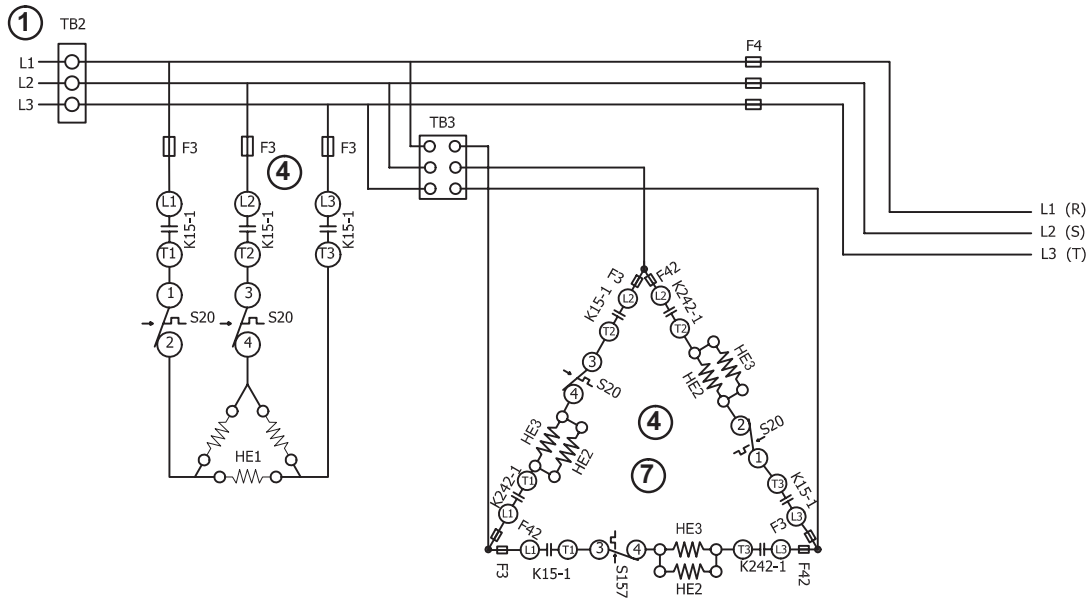

		KW	HE1	HE2	HE3	
072	060	036	7.5	7.5		
		046	15	15		
			22.5		15	7.5
			30		15	15

01/15		WIRING DIAGRAM	01/15
		537806-01	
HEATING - ELECTRIC			
TIEH - 7.5,15,22.5,30 Y			
HEATING SECTION A4			REV 0
Supersedes	535,049W	New Form No.	537806-01

T1EHA-7.5, 15, 22.5kW G, J VOLTAGE SERIES UNITS

24V POWER

KEY	DESCRIPTION	COMPONENT
F3	FUSE-ELECTRIC HEAT	
F4	FUSE-UNIT	
HE1	ELEMENT-ELECTRIC HEAT 1	
HE2	ELEMENT-ELECTRIC HEAT 2	
K9,-1	RELAY-HEAT	
K15,-1	CONTACTOR-ELECTRIC HEAT 1	
P2	PLUG-UNIT HEAT	
S15	SWITCH-LIMIT, PRIMARY ELECT HT	
S20	SWITCH-LIMIT, SECONDARY ELECT HT	
S157	SWITCH-LIMIT, SECONDARY ELECT HT 2	
TB2	TERMINAL STRIP-UNIT	

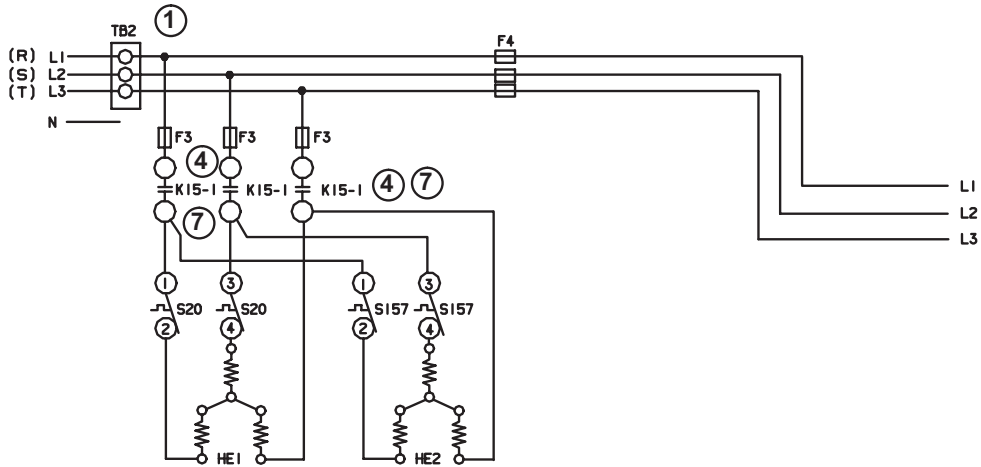
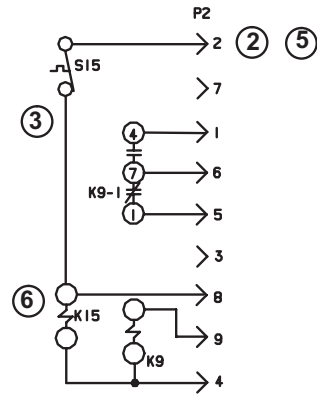

072	060	036	048	KW	HE1	HE2
				7.5	7.5	7.5
				15	15	15
				22.5	15	15
				30	15	15

WIRING DIAGRAM		9/05
HEATING-ELECTRIC		
T1EH-7.5, 15, 22.5, 30-G, J, M		
A BOX		
HEATING SECTION A2		
Superseded Form No.	New Form No. 535,047W	

© 2005

Litho U.S.A.

Sequence of Operation -T1EH 7.5, 10, 15, 22.5- P Voltage

HEATING ELEMENTS:

- 1 - Terminal Strip TB2 is energized when the unit disconnect closes. TB2 supplies line voltage to electric heat elements HE1 and TB3. TB3 supplies line voltage to HE2 through HE6. Elements are protected by fuses F3 and F42.

SECOND STAGE HEAT:

- 2 - Heating demand initiates at W2 in thermostat.
- 3 - 24VAC W2 is routed from the indoor thermostat through N.C. primary limit S15. Electric heat contactor K15 and heat relay K9 are energized. K9 energizes blower contactor K3 and economizer.
- 4 - 7.5kW units - N.O. contacts K15-1 close energizing HE1.
10kW 15kW units - K15-1, K16-1, K15-2 and K16-2 close energizing HE2 and HE3.
22.5kW units - K15-1, K15-2, K15-3, K16-1, K16-2, K16-3 close energizing HE4, HE5 and HE6.

END OF SECOND STAGE HEAT:

- 5 - Heating demand is satisfied. Terminal W2 in the thermostat is de-energized.
- 6 - Electric heat contactor K15 is de-energized.
- 7 - 7.5kW units - N.O. contacts K15-1, open de-energizing HE1.
15kW units - K15-1, K15-2, K16-1, K16-2 open de-energizing HE2 and HE3.
22.5kW units - K15-1, K15-2, K15-3, K16-1, K16-2 and K16-3 open de-energizing HE4, HE5 and HE6.

Sequence of Operation -T1EH 7.5, 15, 22.5, 30 kW - G, J and M Voltage

HEATING ELEMENTS:

- 1 - Terminal Strip TB2 is energized when the unit disconnect closes. TB2 supplies line voltage to electric heat elements HE1 and TB3. TB3 supplies line voltage to HE2 and HE3. Elements are protected by fuses F3 and or F42.

SECOND STAGE HEAT:

- 2 - Heating demand initiates at W2 in thermostat.
- 3 - 24VAC is routed from the indoor thermostat through N.C. primary limit S15. Electric heat contactor K15 and heat relay K9 are energized. Heat relay K9 energizes blower contactor K3 and economizer.
- 4 - 7.5kW and 15kW units - N.O. contacts K15-1 close energizing HE1.
22.5kW and 30kW units - N.O. contacts K15-01 close energizing HE2 and HE3.

END OF SECOND STAGE HEAT:

- 5 - Heating demand is satisfied. Terminal W2 in the thermostat is de-energized.
- 6 - Electric heat contactor K15 is de-energized.
- 7 - 7.5kW and 15kW units - N.O. contacts K15-1 open deenergizing HE1.
22.5kW and 30kW units - N.O. contacts K15-01 open de-energizing HE2 and HE3.

Sequence of Operation -T1EH 7.5, 15, 22.5, 30 kW - Y Voltage

HEATING ELEMENTS:

- 1 - Terminal Strip TB2 is energized when the unit disconnect closes. TB2 supplies line voltage to electric heat elements HE1 and TB3. TB3 supplies line voltage to HE2 and HE3. Elements are protected by fuses F3 and or F42.

SECOND STAGE HEAT:

- 2 - Heating demand initiates at W2 in thermostat.
- 3 - 24VAC is routed from the indoor thermostat through N.C. primary limit S15. Electric heat contactor K15 and heat relay K9 are energized. Heat relay K9 energizes blower contactor K3 and economizer.

- 4 - 7.5kW and 15kW units - N.O. contacts K15-1 close energizing HE1.
22.5kW and 30kW units - N.O. contacts K242-1 close energizing HE2 and HE3.

END OF SECOND STAGE HEAT:

- 5 - Heating demand is satisfied. Terminal W2 in the thermostat is de-energized.
- 6 - Electric heat contactor K15 is de-energized.
- 7 - 7.5kW and 15kW units - N.O. contacts K15-1 open deenergizing HE1.
22.5kW and 30kW units - N.O. contacts K242-1 open de-energizing HE2 and HE3.