

MODEL L™ R-454B QUICK REFERENCE GUIDE

3- to 25-ton packaged gas/electric and electric/electric ultra-high efficiency rooftop units

MODEL / L

Ultimate Performance, Comfort, and Control



ENERGY OPTIMIZATION

Model L rooftop units deliver the lowest total cost of ownership through variable-speed components and intelligent operation.



ENGINEERED INTELLIGENCE

The Lennox® CORE control system delivers connected service, open integration, reliable performance, and efficiency optimization to empower all parts of your organization.



COMPLETE COMFORT

Advanced technologies deliver premium comfort and indoor air quality in a wide range of applications.



SIMPLE SERVICE

Model L rooftop units maximize efficiency of maintenance and service operations, reducing operational costs and minimizing downtime.

3- TO 25-TON PACKAGED ROOFTOP PERFORMANCE DATA (GAS OR ELECTRIC HEAT) - ULTRA-HIGH EFFICIENCY

Size (Tons) / Cabinet	3 Ton / A	4 Ton / A	5 Ton / A	6 Ton / A	7.5 Ton / B	8.5 Ton / B	10 Ton / B	12.5 Ton / B	13 Ton / C	15 Ton / C	17.5 Ton / C	20 Ton / C	25 Ton / C	
Efficiency	Ultra-High	Ultra-High	Ultra-High	Ultra-High	Ultra-High	Ultra-High	Ultra-High	Ultra-High	Ultra-High	Ultra-High	Ultra-High	Ultra-High	Ultra-High	
Model Number	LCM/LGM036U5E LCM/LGM036U5P	LCM/LGM048U5E LCM/LGM048U5P	LCM/LGM060U5E LCM/LGM060U5P	LCM/LGM074U5E LCM/LGM074U5P	LCM/LGM092U5E LCM/LGM092U5P	LCM/LGM102U5E LCM/LGM102U5P	LCM/LGM120U5E LCM/LGM120U5P	LCM/LGM150U5E LCM/LGM150U5P	LCM/LGM156U5M LCM/LGM156U5V	LCM/LGM180U5M LCM/LGM180U5V	LCM/LGM210U5M LCM/LGM210U5V	LCM/LGM240U5M LCM/LGM240U5V	LCM/LGM300U5M LCM/LGM300U5V	
Blower Type	SZVAV/VAV	SZVAV/VAV	SZVAV/VAV	SZVAV/VAV	SZVAV/VAV	SZVAV/VAV	SZVAV/VAV	SZVAV/VAV	SZVAV/VAV	SZVAV/VAV	SZVAV/VAV	SZVAV/VAV	SZVAV/VAV	
Net Cooling Capacity (Btuh)	35,000	48,000	58,000	69,000	88,000	97,000	114,000	136,000	150,000	172,000	200,000	228,000	270,000	
Compressor Qty and Type	1 Variable-speed				1 Variable-speed, 1 fixed-speed				1 Variable-speed, 2 fixed-speed		1 Variable-speed, 3 fixed-speed			
EER/EER2*	14.3	13.2	12.5	12.2	12.7 (E/E) 12.5 (G/E)	12.7 (E/E) 12.5 (G/E)	12.2 (E/E) 12.0 (G/E)	11.0 (E/E) 10.8 (G/E)	12.2 (E/E) 12.0 (G/E)	12.2 (E/E) 12.0 (G/E)	12.2 (E/E) 12.0 (G/E)	12.2 (E/E) 12.0 (G/E)	10.8 (E/E) 10.6 (G/E)	
SEER2 (036-060) IEER (074-300)	21.2	19.9	19.5	23.1	21.0	21.0	20.7	19.5	19.0 (SZVAV) 18.5 (VAV)	19.0 (SZVAV) 17.5 (VAV)	18.8 (SZVAV) 18.0 (VAV)	18.4 (SZVAV) 17.5 (VAV)	17.5 (SZVAV) 16.5 (VAV)	
Gas Heat Sizes (Up to stages)	2	2	2	2	2	2	2	2	4	4	4	4	4	
Electric Heat Sizes (kW)	7.5, 15		7.5, 15, 22.5		7.5, 15, 22.5, 30		7.5, 15, 22.5, 30, 45		15, 22.5, 30, 45, 60		15, 30, 45, 60		15, 30, 45, 60, 90	
Blower Motor Size (HP)	1.5				3.75				3,5	3,5,7.5	3,5,7.5	5,7.5,10	5,7.5,10	
Weight - Net (lbs.) G/E	618	636	636	636	1115	1115	1150	1170	2200	2204	2643	2669	2710	
Weight - Net (lbs.) E/E	598	616	616	616	1067	1067	1102	1122	2051	2054	2498	2524	2565	
Cabinet Size - H x W x L (in.)	47 x 47 x 86				47 x 61 x 102				55 x 92 x 133					
Filters (Qty) - Size (in.)	(4) 20 x 20 x 2				(4) 20 x 25 x 2				(6) 24 x 24 x 2					
Sound (dBA)	73	76	78	80	85	85	89	89	86	86	90	90	90	



* EER2 ratings apply to equipment less than 65,000 btuh.



FACTORY- AND FIELD-INSTALLED OPTIONS

OPTION	FACTORY	FIELD
COOLING		
Condensate Drain Trap (PVC and Copper)	•	•
Drain Pan Overflow Switch	•	•
Refrigerant Type (R-454B)	•	
BLOWER		
DirectPlus Direct Drive ECM Blower with SZVAV	•	
DirectPlus Direct Drive ECM Blower with VAV	•	
SZVAV - With/Without VFD Bypass Control **	•	
VAV - Without VFD Bypass Control **	•	
Supply Fan Drive Kits **	•	
HEATING		
Bottom Gas Piping Kit		•
Combustion Air Intake Extensions		•
Gas Heating	•	
Low-Temperature Vestibule Heater		•
LPG/Propane Conversion Kits		•
Stainless Steel Heat Exchanger	•	
Vertical Vent Extension		•
DEHUMIDIFICATION		
Humiditrol™+ Hot-Gas Reheat Dehumidification System	•	
Enhanced Dehumidification	Standard	
CONTROLS		
Lennox® CORE Unit Controller	Standard	
BACnet® IP & MS/TP	Standard	
Commercial Controls - Novar LSE	•	
Commercial Controls - L Connection BAS		•
Blowing Proving Switch	•	•
Dirty Filter Switch	Standard	•
Fresh Air Tempering	•	•
Smoke Detector Supply and/or Return	•	•
LonTalk®	•	•
After-Market DDC and/or Thermostats		•
Outdoor Air CFM Control		•

OPTION	FACTORY	FIELD
INDOOR AIR QUALITY		
MERV 8 Filters	•	•
MERV 13 Filters	•	•
MERV 16 Filters	•	•
Replacement Media Filter With Metal Mesh		•
Demand Control Ventilation - IAQ (CO ₂) Sensors		•
Needlepoint Bipolar Ionization (NPBI) Kit		•
UVC Germicidal Light Kit		•
ELECTRICAL		
208/230, 460V, 575V - 3ph, 60Hz	•	
HACR Circuit Breakers	•	
Disconnect Switch	•	•
SCCR up to 100kA	•	
GFI Service Outlets	•	•
Weatherproof Cover For GFI		•
Electric Heat	•	•
OUTDOOR AIR		
High Performance Economizer - (AMCA Class 1A Certified)	•	•
Economizer Controls - Single and/or Differential Enthalpy	•	•
Economizer Controls - Sensible	•	•
Downflow Barometric Relief Dampers	•	•
Horizontal Barometric Relief Dampers		•
Manual Outdoor Air Dampers		•
Motorized Outdoor Air Dampers	•	•
Power Exhaust Fan Standard Static	•	•
ROOF CURBS/CEILING DIFFUSERS		
Roof Curbs - Hybrid		•
Roof Curbs - Standard, Adjustable		•
Insulation Kit - Standard		•
Transition Curb		•
Ceiling Diffusers		•
CABINET		
Combination Coil/Hail Guards	•	•
Corrosion Protection (indoor coil/outdoor coil)	•	•

Tonnage	LENGTH		WIDTH		SUPPLY AIR		RETURN AIR	
	L	W	SL	SW	RL	RW		
036 TO 074 (A)	79-3/4	41-1/2	19-1/8	21-1/8	12-5/8	32		
092 TO 150 (B)	95-3/8	54-1/4	29-3/4	21-3/4	26-3/4	29-3/4		
156 TO 300 (C)	86-1/8	98-1/2	21	61-1/2	16	61-1/2		

*Not available on units with Humiditrol™+
 **Applies to 13- to 25-ton models only.

For 036-150 Models

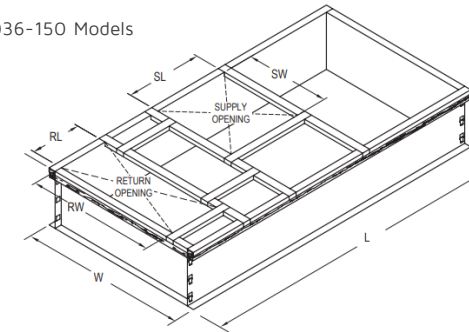

For 156-300 Models

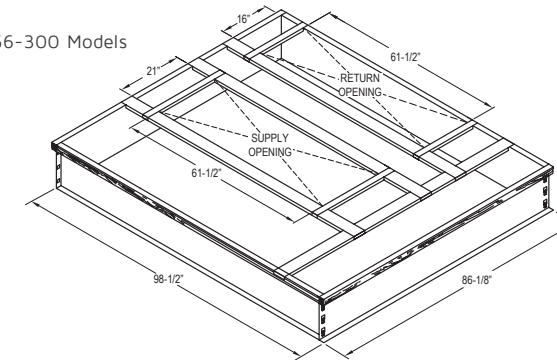

Note - Due to Lennox' ongoing commitment to quality, all specifications, ratings and dimensions are subject to change without notice.

Visit us at www.lennox.com
 For the latest technical information, www.lennoxcommercial.com
 Contact us at 1-800-4-LENNOX
 ©2024 Lennox Industries, Inc.

37J44 12/24