

# PACKAGED UNITS KITS AND ACCESSORIES

506410-06  
12/2024  
Supersedes 506410-05

## COLD WEATHER KIT

### INSTALLATION INSTRUCTIONS FOR COLD WEATHER KIT USED ON LG/LD/KG/KD 092-300, SG 120 GAS PACKAGED UNITS

#### **⚠️WARNING**

Improper installation, adjustment, alteration, service or maintenance can cause property damage, personal injury or loss of life. Installation and service must be performed by a licensed professional HVAC installer or equivalent, service agency, or the gas supplier.

#### Shipping and Packing List

**13X63, 13X64, 13X65, 22A51, 22A55, 31A65, 31A66**

**Package 1 of 1 contains:**

- 1- Heater assembly
- 4- Wire harnesses (2 in 13X63 & 13X64)

Bag assembly containing:

- 1-Relay
- 9-#8 Screws
- 1-Wire tie

**22H58, 22H59, 22V43**

**Package 1 of 1 contains:**

- 2- Heater assemblies
- 7- Wire harnesses
  - 1- 106051-01 (LGH units)
  - 1- 604785-01 (KG Units- std. SCCR)
  - 2- 106128-01 HR6 power harnesses (KG)
  - 1- 105722-01 (LGH units - higher SCCR)
  - 1- 106648-01 (LGM units)
  - 1- 107210-01 (LGT/LDT units)
  - 1- 108303-01 (LGT/LDT 302-360)

Bag assembly containing:

- 2- Relays
- 18- Thread forming screws
- 24- Wire ties

#### **⚠️WARNING**

**To prevent serious injury or death:**

1. Lock-out/tag-out before performing maintenance.
2. If system power is required (e.g., smoke detector maintenance), disable power to blower, remove fan belt where applicable, and ensure all controllers and thermostats are set to the "OFF" position before performing maintenance.
3. Always keep hands, hair, clothing, jewelry, tools, etc., away from moving parts.

#### Application

The cold weather kit heats the gas heat compartment to allow gas valve operation during low outdoor temperatures. See TABLE 1 for usage.

**TABLE 1**

Unit	Unit Voltage	Part No.	Cat. No.
LGH/KG 092-152	Y	613930-01	13X63
LGH/KG 092-152	G, M	613930-02	13X64
LGM/LGT/LD/KG/KD 078-152	J	613930-03	13X65
LGM/LGT/LD/KD 078-152	Y	613930-07	22A51
LGM/LGT/LD/KD 078-152	G, M	613930-08	22A55
LG/LD/KG 156-300(S)	Y	613930-10	22H58
LG/LD/KG 156-300(S)	G, M	613930-11	22H59
LG/LD/KG 156-300(S)	J	613930-12	22V43
SG 120	G	613930-14	31A65
SG 120	J	613930-15	31A66

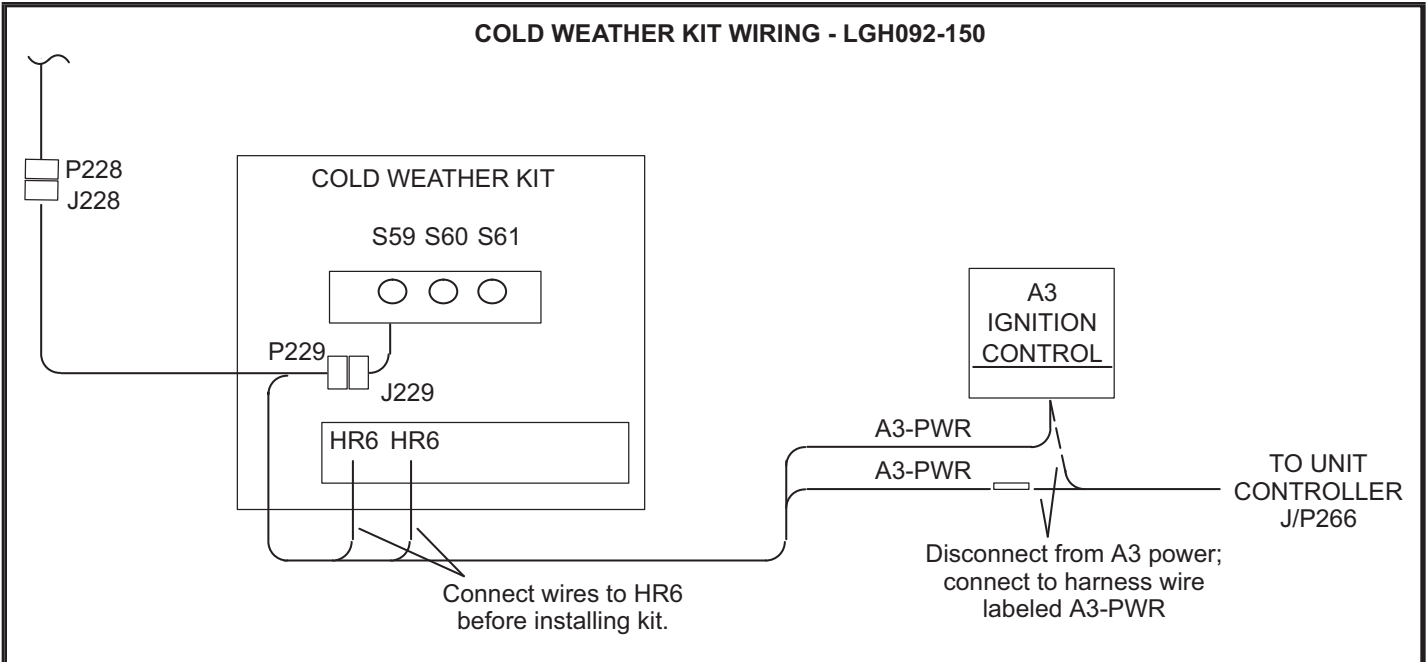
#### Installation - LGH092-150 Units

- 1 - Disconnect all power to unit and open heat access panel.
- 2 - Locate the kit harness labeled 604954-01 kit harness. Remove cold weather kit cover and connect wires labeled HR6 to the cold weather assembly. See FIGURE 1. Replace cold weather kit cover. Discard harness labeled 604956-01 provided in kit
- 3 - Install heater assembly in heat section as shown in FIGURE 2. Use existing screws.
- 4 - Route the remaining harness wires as shown in FIGURE 2. Make wire connections as shown in FIGURE 1.
- 5 - Open control access panel and install K125 as shown in FIGURE 3. Secure with #8 screws provided in kit.
- 6 - Locate existing wires in control box and connect to K125 as shown in FIGURE 3 for standard SCCR units and FIGURE 4 for high SCCR units.

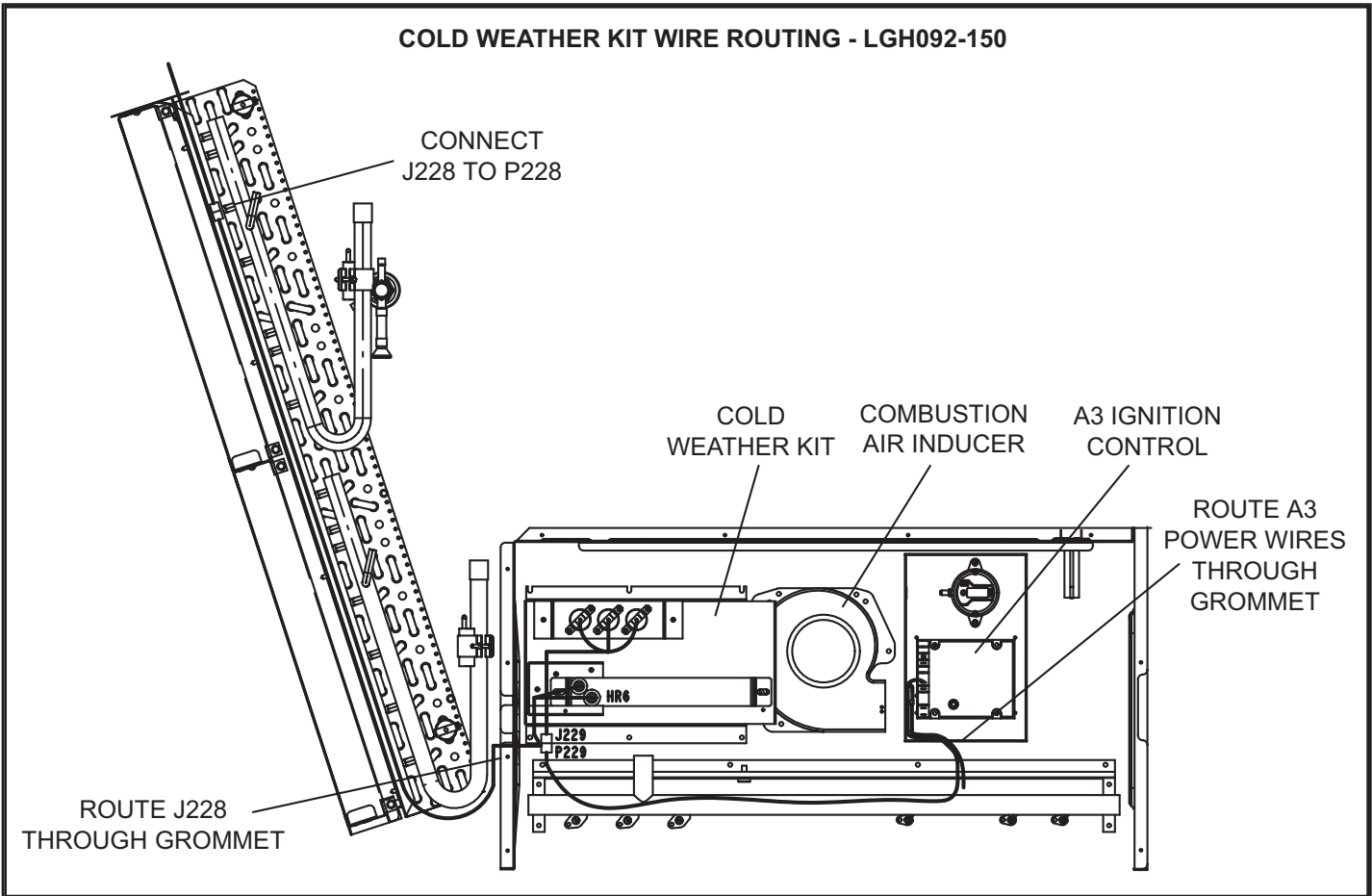
#### **⚠️CAUTION**

**As with any mechanical equipment, contact with sharp sheet metal edges can result in personal injury. Take care while handling this equipment and wear gloves and protective clothing.**

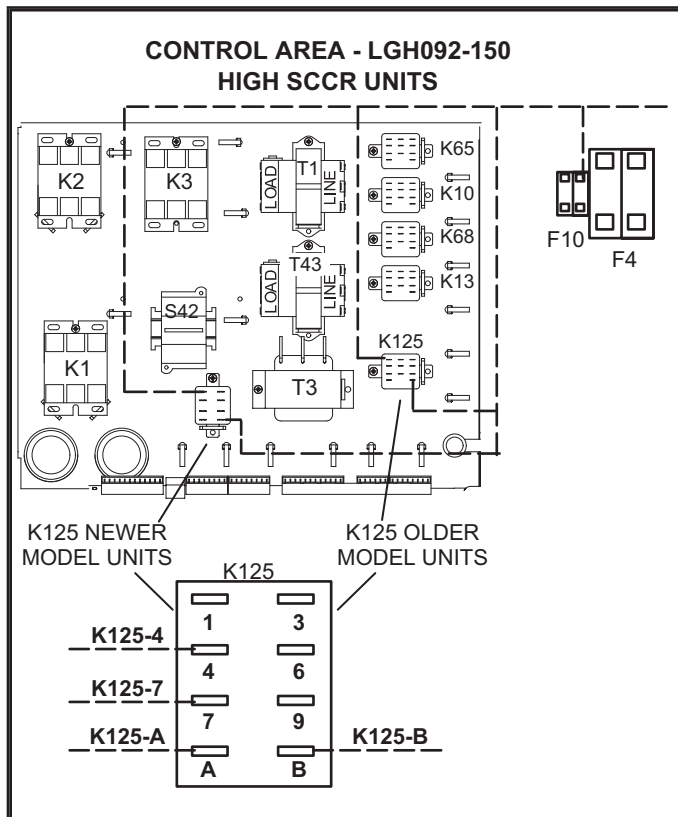
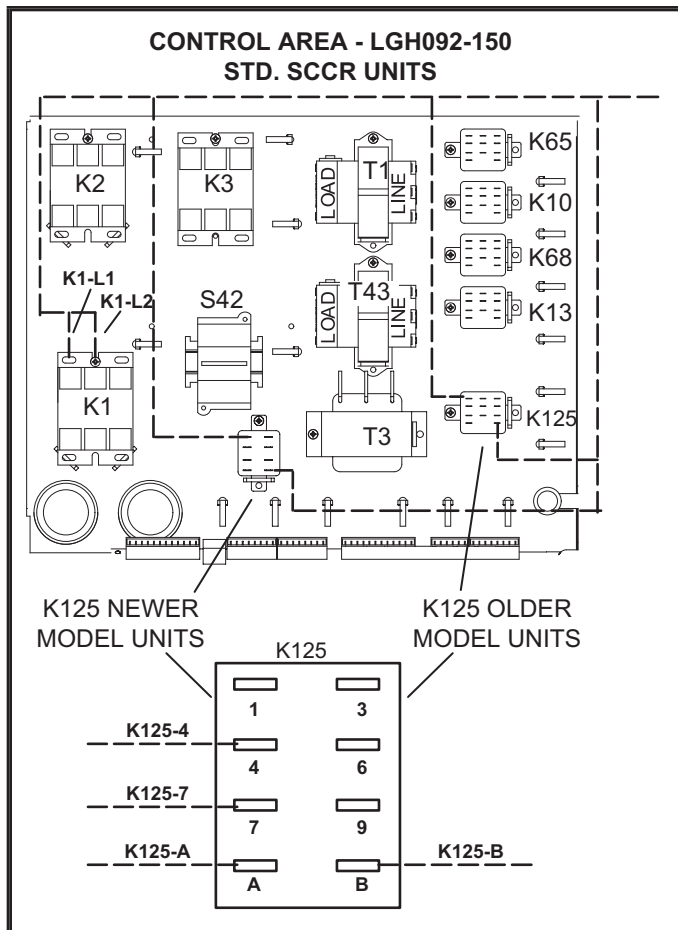




**FIGURE 1**

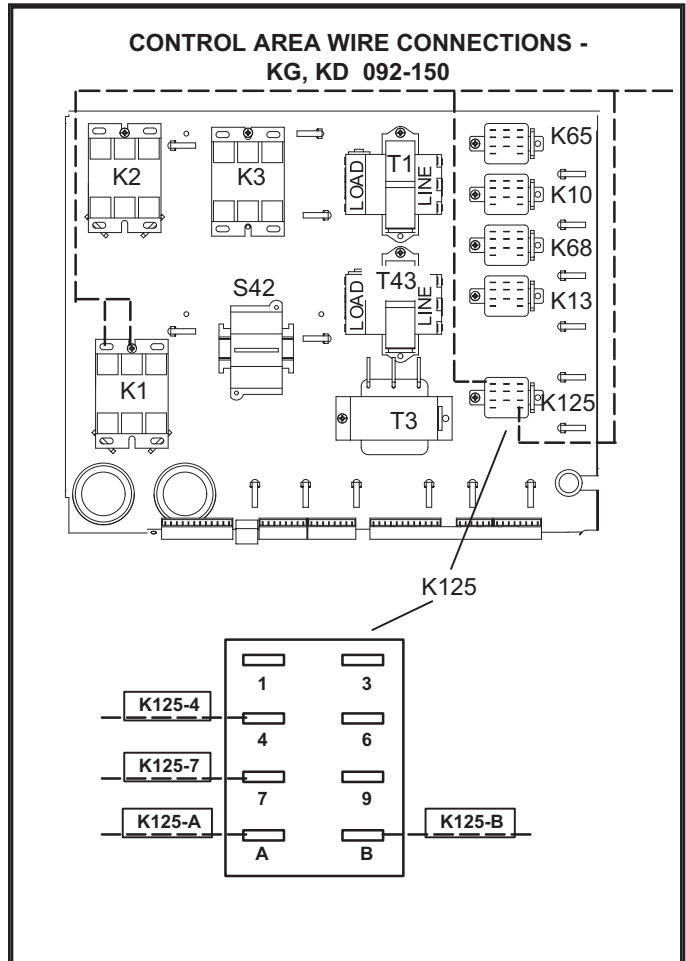


**FIGURE 2**



**Installation - KG, KD 092-150 Units**

- 1 - Disconnect all power to unit and open heat access panel.
- 2 - Remove six screws that are holding the unit top to the compressor area corner mullion.
- 3 - Locate the kit harness labeled 604956-01 and identify six wires labeled K1-L1, K1-L2, K125-4, K125-7, K125-A, and K125-B. Route the six wires from the heat section through the side grommet to the control box. See FIGURE 6. Discard harness labeled 604954-01 provided in kit
- 4 - Remove cold weather kit cover and connect wires labeled HR6 to the cold weather assembly. See FIGURE 7. Replace cold weather kit cover.
- 5 - Install heater assembly in heat section as shown in FIGURE 2. Use existing screws.
- 6 - Open control access panel and install K125 as shown in FIGURE 3. Secure with #8 screws provided in kit.
- 7 - Make wire connections in the control box as shown in FIGURE 5 and in the heat section as shown in FIGURE 7.
- 8 - Replace top panel and secure in place.



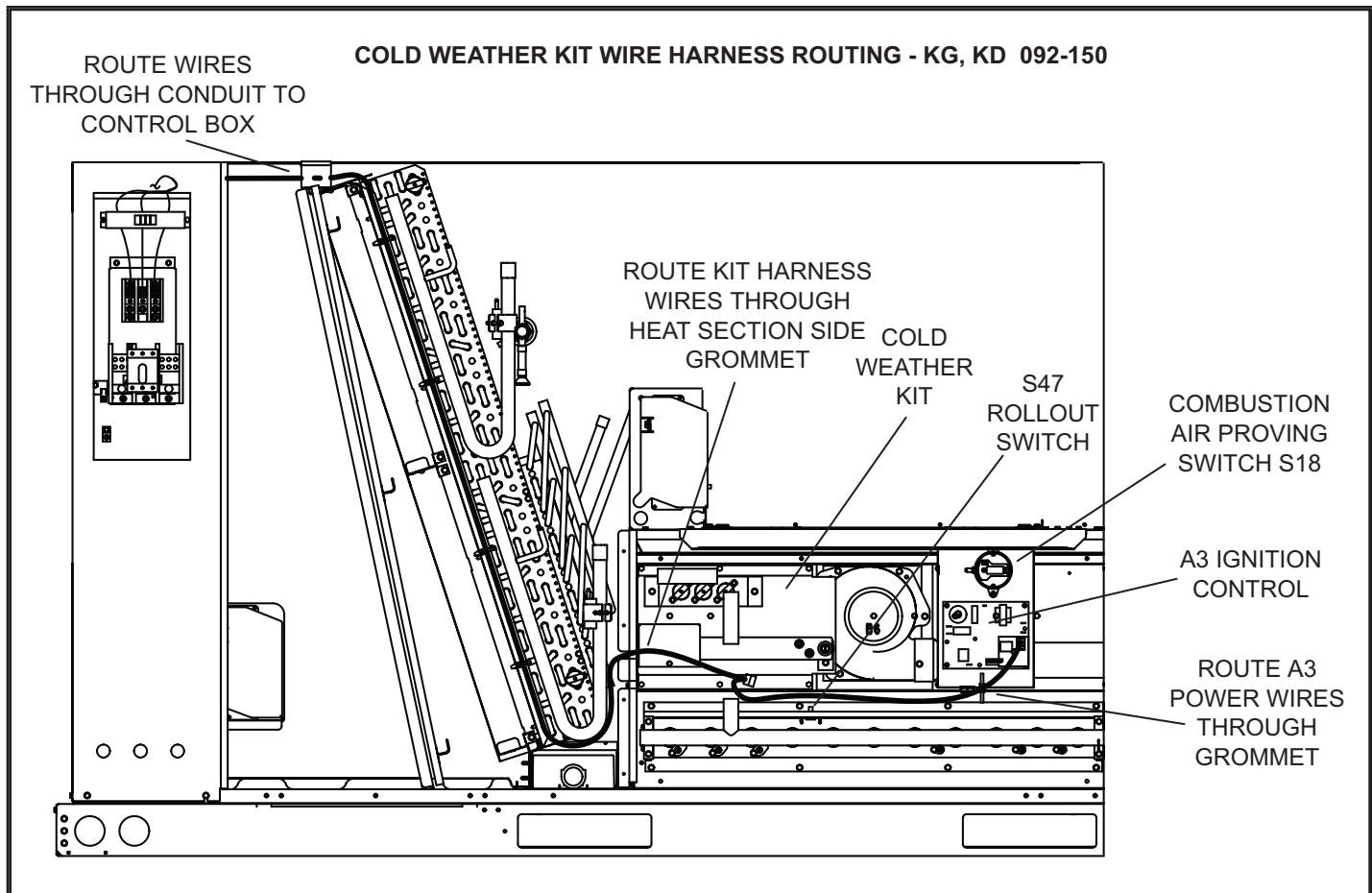


FIGURE 6

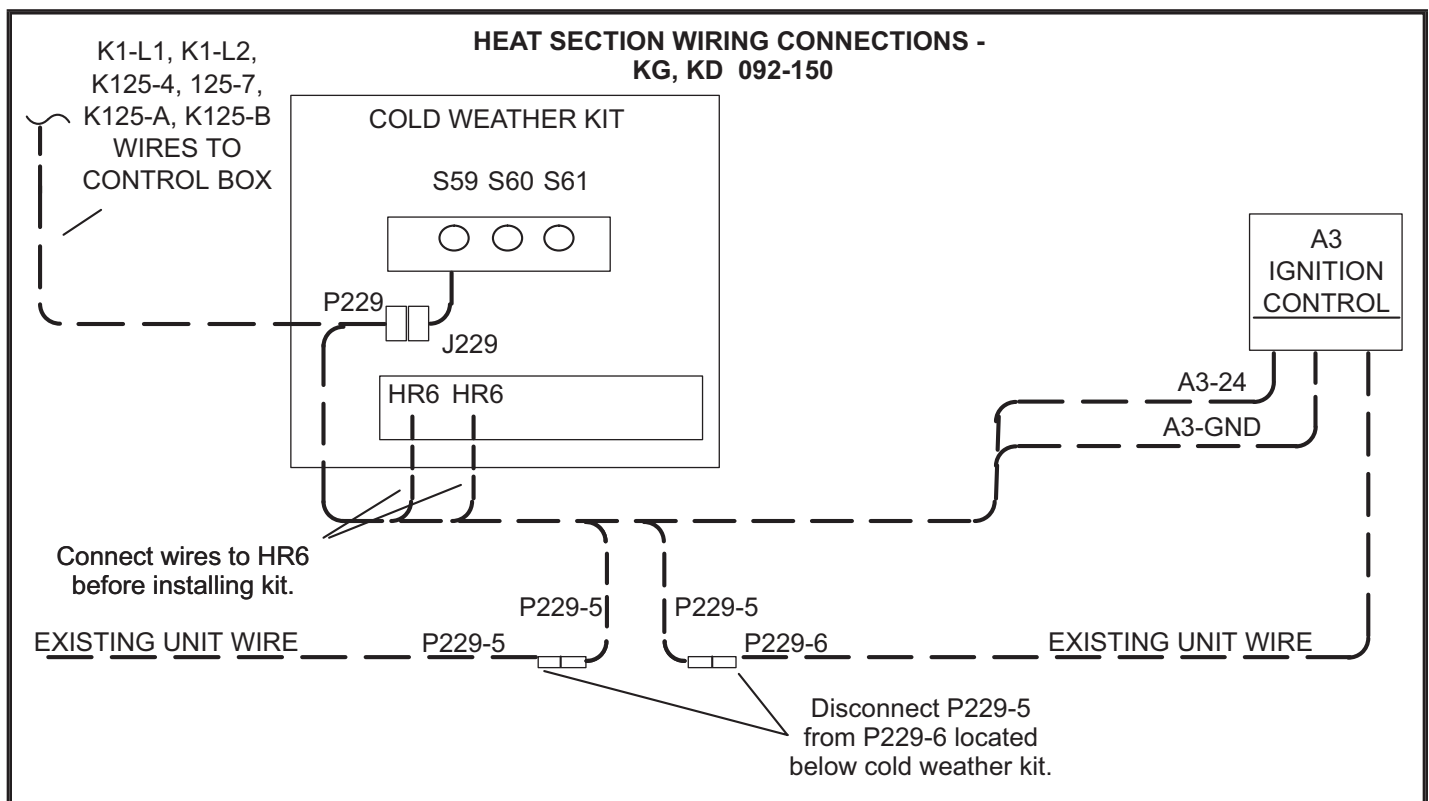


FIGURE 7

## Installation - LGM, LGT, LDT 092-150

- 1 - Disconnect all power to unit and open heat access panel. See FIGURE 8.
- 2 - Discard harnesses labeled 604954-01 and 604956-01. Locate the kit power harness which has two 2-pin connectors labeled J/P228.
- 3 - Remove strip heater junction box cover. Route two power harness wires labeled HR6 through the junction box side grommet and connect to the strip heater terminals. See FIGURE 9. Replace junction box cover.
- 4 - Install heater assembly in heat section as shown in FIGURE 10. Use existing screws.
- 5 - Remove ignition control cover and install K125 as shown in FIGURE 10. Secure with #8 screws provided in kit.
- 6 - Disconnect unit J/P425 connectors. See FIGURE 10. Connect power harness J/P228 to J/P425. See FIGURE 11.
- 7 - Route remaining power harness wires labeled K125-4, -6, -7, -9 through the grommets in the bottom of the ignition control box. Connect to appropriate terminals.

- 8 - Locate kit control harness that has a 6-pin, 4-wire connector labeled P229. Connect P229 to J229 cold weather kit harness. See FIGURE 12.
- 9 - Route the other end of the P229 harness to the heat section and make wire connections. See FIGURE 13.

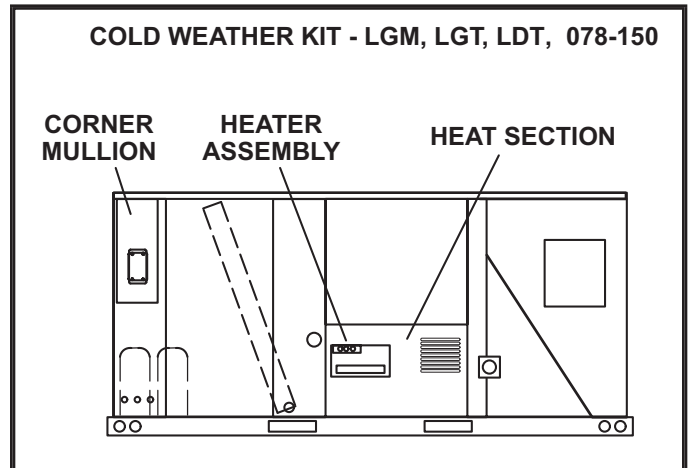


FIGURE 8

## CONNECT STRIP HEATER WIRES - LGM, LGT, LDT 078-150

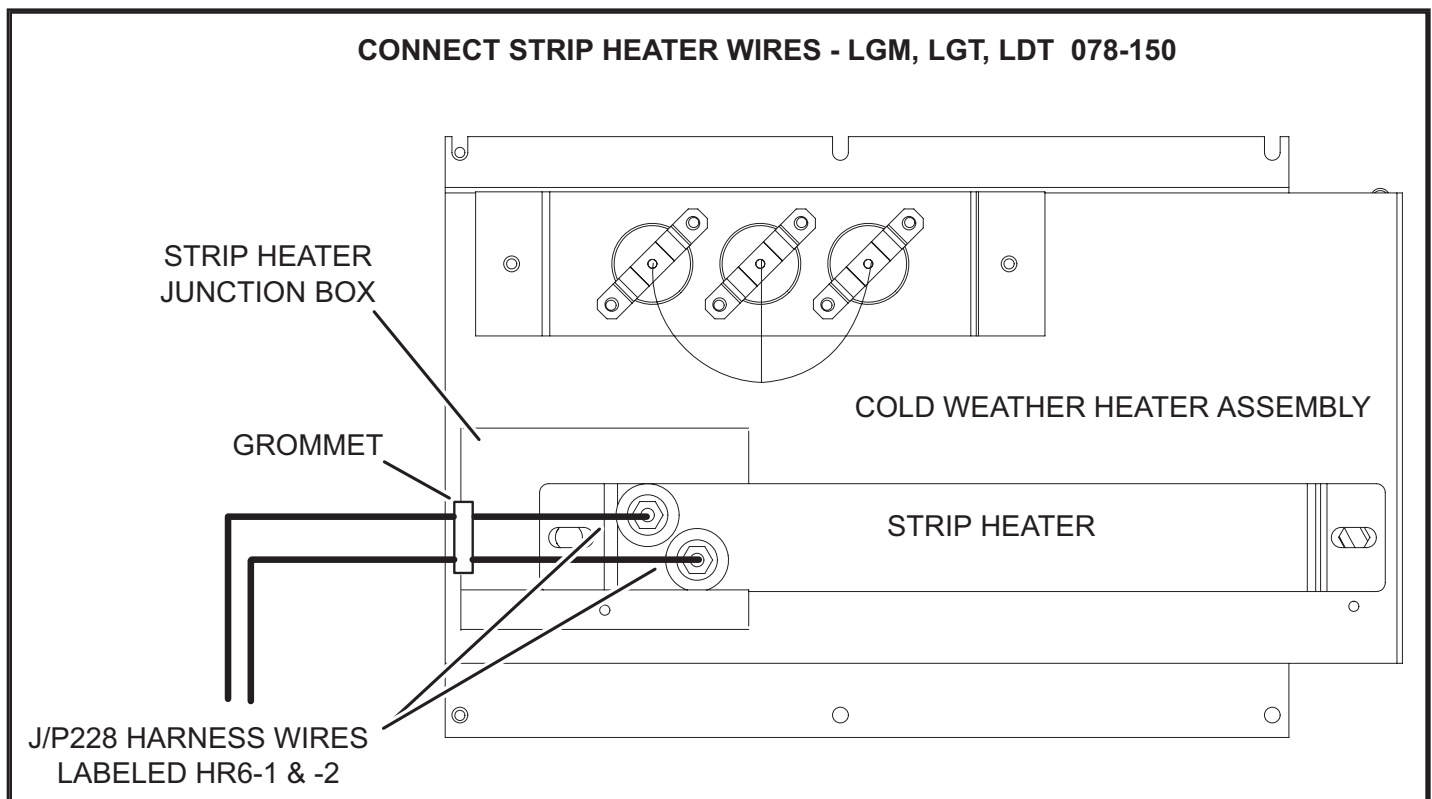
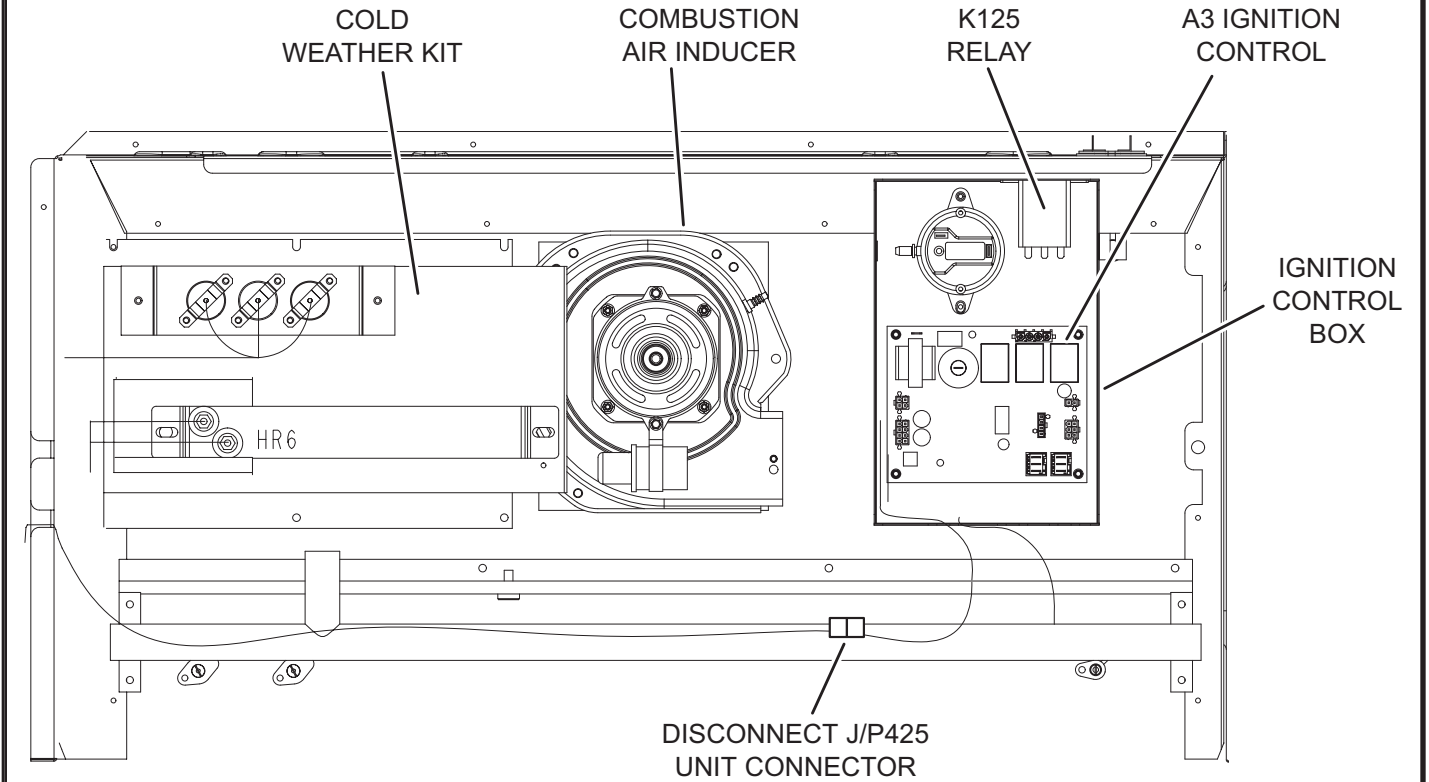


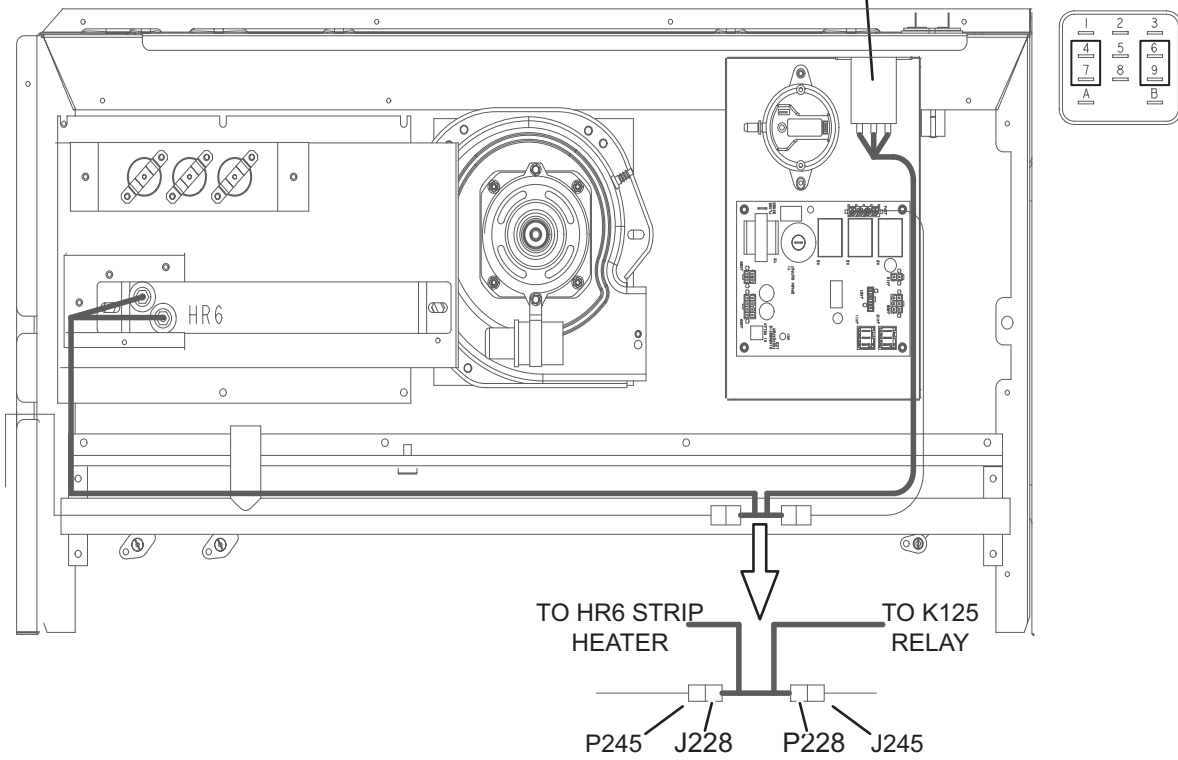
FIGURE 9

**INSTALL HEATER ASSEMBLY - LGM, LGT, LDT 078-150**



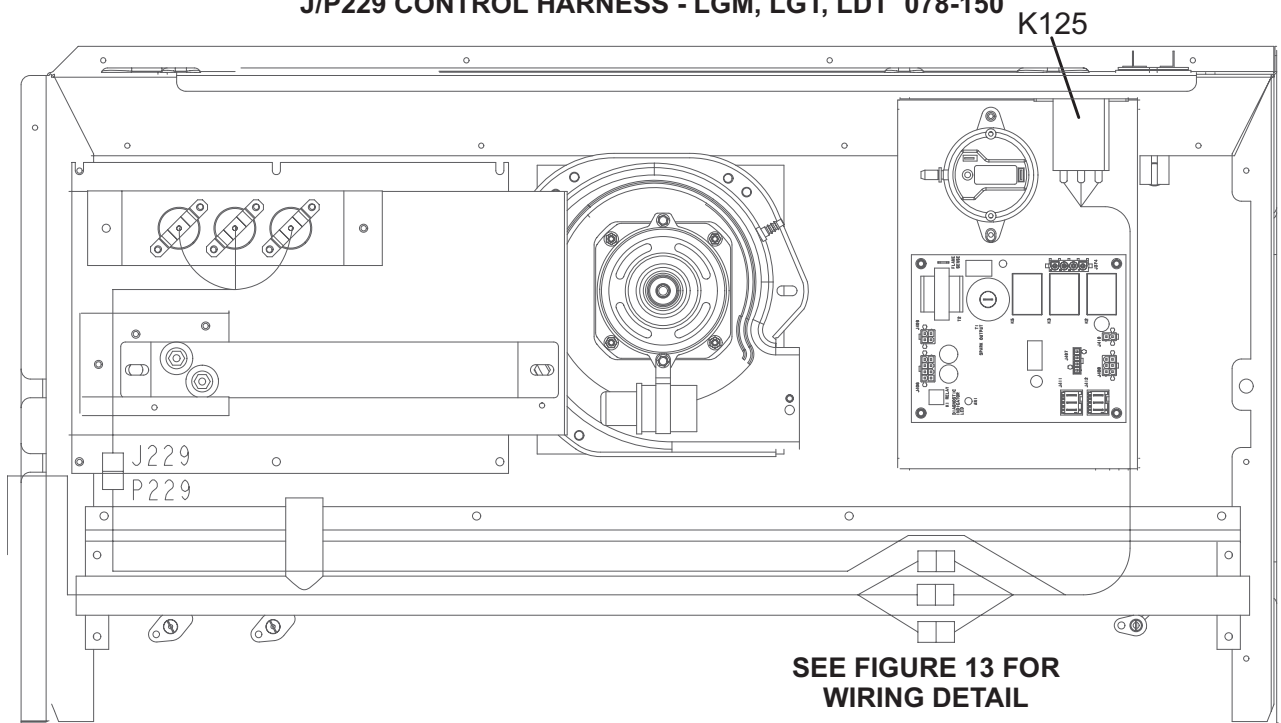
**FIGURE 10**

**J/P228 POWER HARNESS - LGM, LGT, LDT 078-150 K125**



**FIGURE 11**

**J/P229 CONTROL HARNESS - LGM, LGT, LDT 078-150**



**SEE FIGURE 13 FOR  
WIRING DETAIL**

**FIGURE 12**

J/P229 CONTROL HARNESS CONNECTIONS - LGM, LGT, LDT 078-150

TO K125  
RELAY COIL

K125-A (10)  
K125-B (11)



CONTROL  
HARNESS P229

GND-1    GND

A3.POWER.M

A3.POWER.F

UNIT HARNESS

UNIT HARNESS

A55.P393-6  
(LTVH-1)

A3 P406-5  
(LTVH-2)

UNIT HARNESS

UNIT HARNESS

DISCONNECT UNIT  
HARNESS WIRES

FIGURE 13



## Installation - LGH156-300 Units

- 1 - Disconnect all power to unit and open heat access panel.
- 2 - Install both cold weather assemblies as shown in FIGURE 14. Use existing screws.
- 3 - Install both K125 relays in control area above compressors. Secure with #8 screws. See FIGURE 15.
- 4 - Locate harness labeled 106051-01 for standard SCCR units or 105722-01 for high SCCR units. Route as shown in FIGURE 15. Secure with wire ties. Discard unused harnesses.
- 5 - Make wire connections as shown in FIGURE 16.
- 6 - Use wire ties to securely route and tie harness away from gas heat manifold.

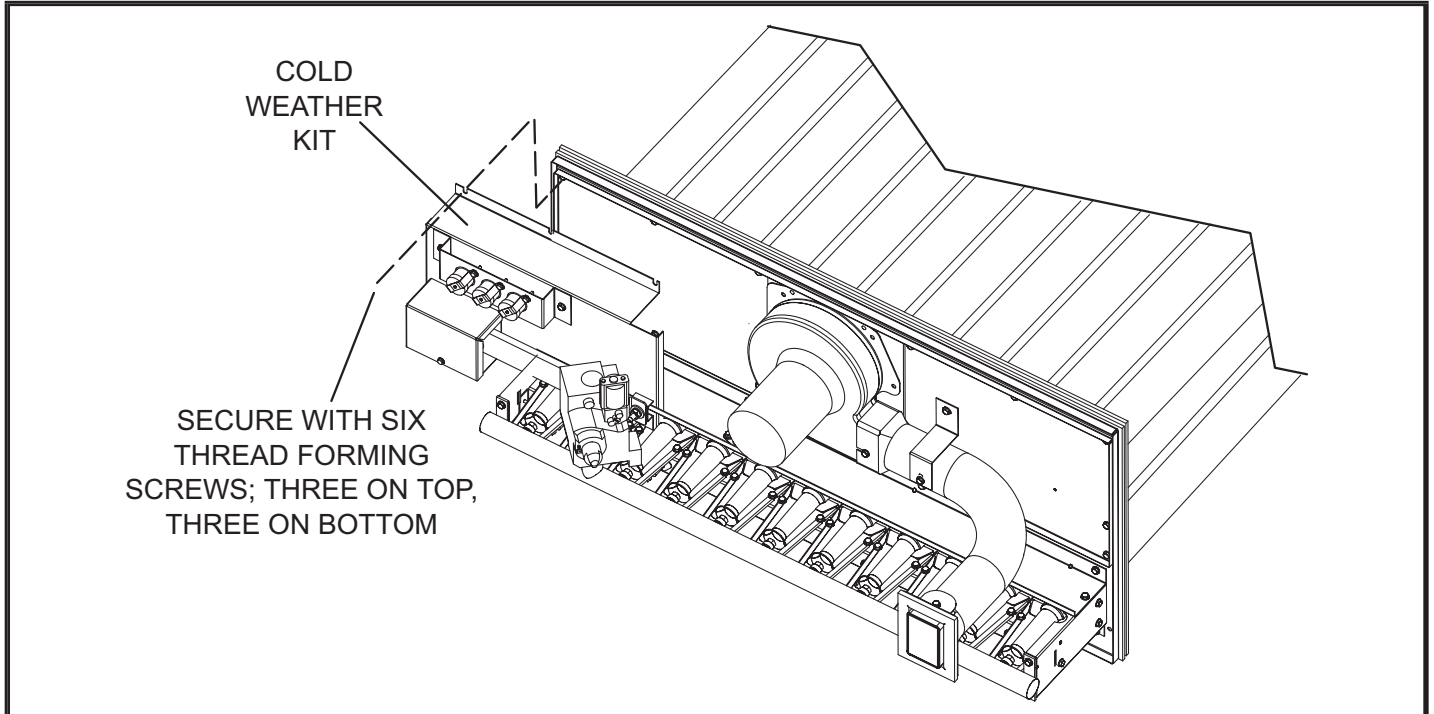


FIGURE 14

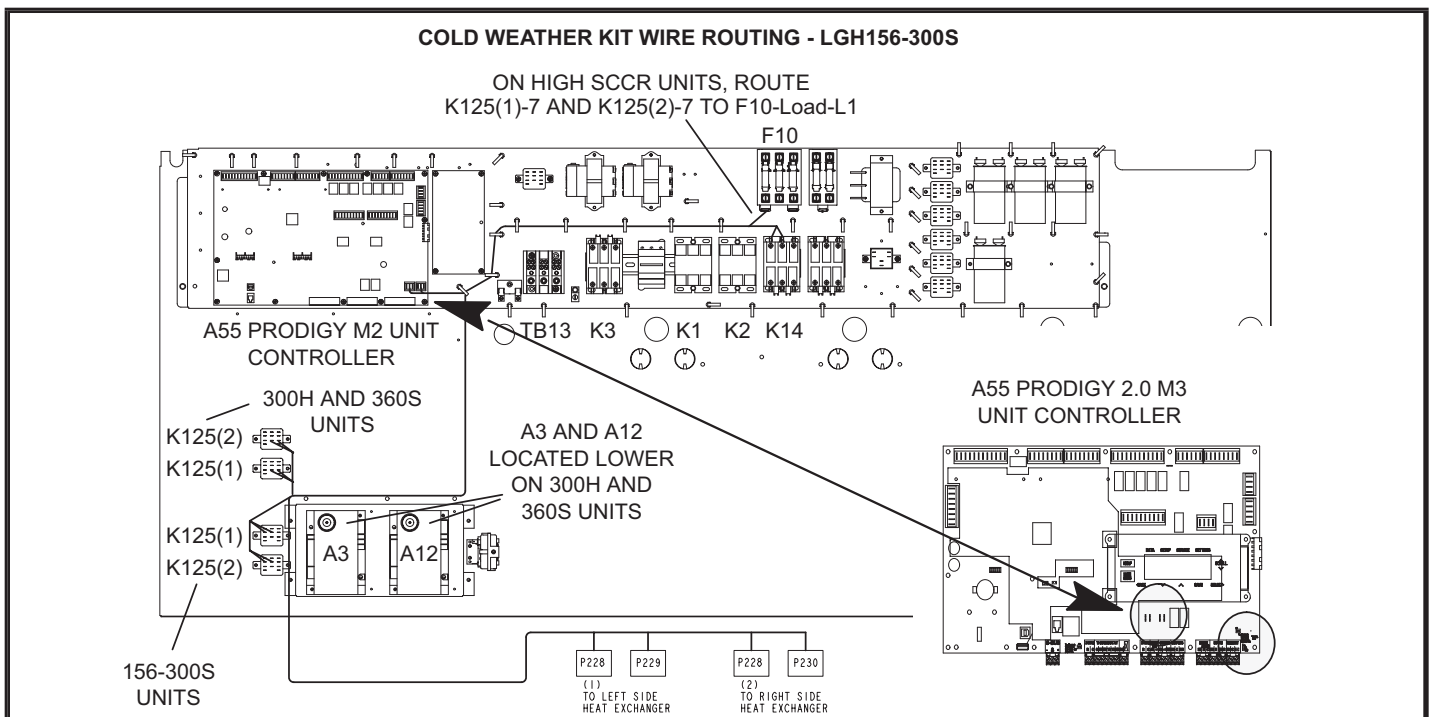


FIGURE 15

**COLD WEATHER KIT WIRING - LGH156-360**

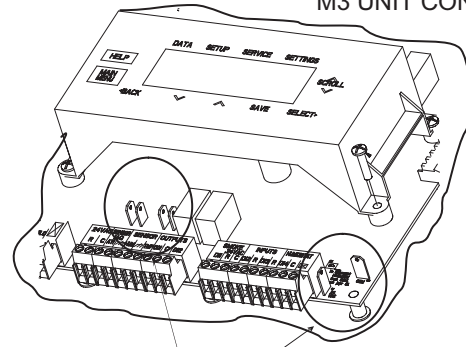
A55 - PRODIGY 2.0  
M3 UNIT CONTROLLER

DISCONNECT WIRES  
FROM IGNITION BOARD  
A3 AND A12

--- KIT HARNESS

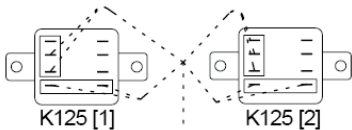
PWR

A3/A12



CONNECT TO A55  
UNIT CONTROLLER

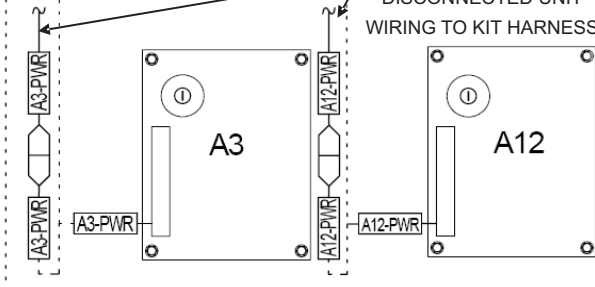
24VAC  
24VAC-COM



K125 [1]

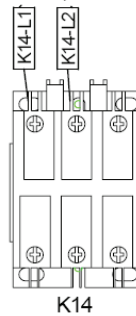
K125 [2]

CONNECT PREVIOUSLY  
DISCONNECTED UNIT  
WIRING TO KIT HARNESS



A3

A12



K14-L1

K14-L2

K14

A55 - PRODIGY  
M2 UNIT CONTROLLER

J228 P228 [1]

J229 P229

VESTIBULE  
HEATER  
ASSEMBLY  
LEFT SIDE

J228 P228 [2]

J230 P230

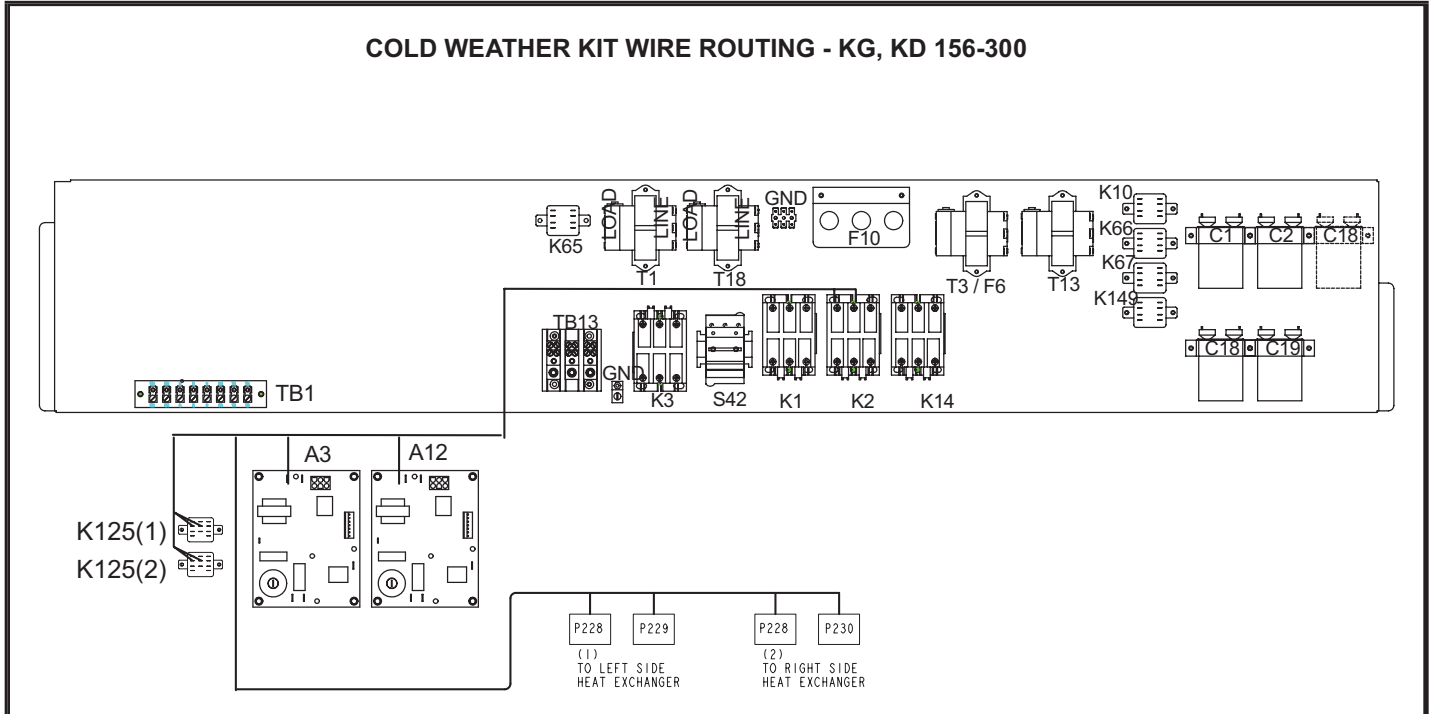
VESTIBULE  
HEATER  
ASSEMBLY  
RIGHT SIDE

**FIGURE 16**

## Installation - KG, KD 156-300 Units

- 1 - Disconnect all power to unit and open compressor access panels.
- 2 - Install both cold weather assemblies as shown in FIGURE 14. Use existing screws.
- 3 - Install both K125 relays in control area above compressors. Secure with #8 screws. See FIGURE 17.

- 4 - Locate harness labeled 604785-01 and route as shown in FIGURE 17. Secure with wire ties. Discard unused harnesses.
- 5 - Make wire connections as shown in FIGURE 18.
- 6 - Use wire ties to securely route and tie harness away from gas heat manifold.



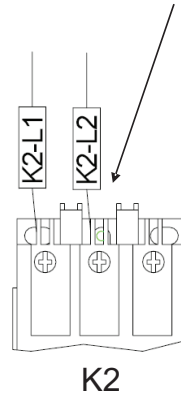
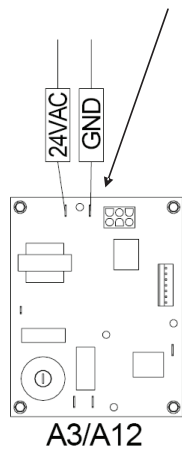
**FIGURE 17**

### COLD WEATHER KIT WIRING - KG, KD 156-300

DISCONNECT WIRES FROM IGNITION BOARD A3 AND A12

DISCONNECT WIRES FROM K2 CONTACTOR

----- KIT HARNESS



DISCONNECT WIRES

S47/S69 ARE LOCATED IN THE WIRE BUNDLE BELOW K125 RELAYS

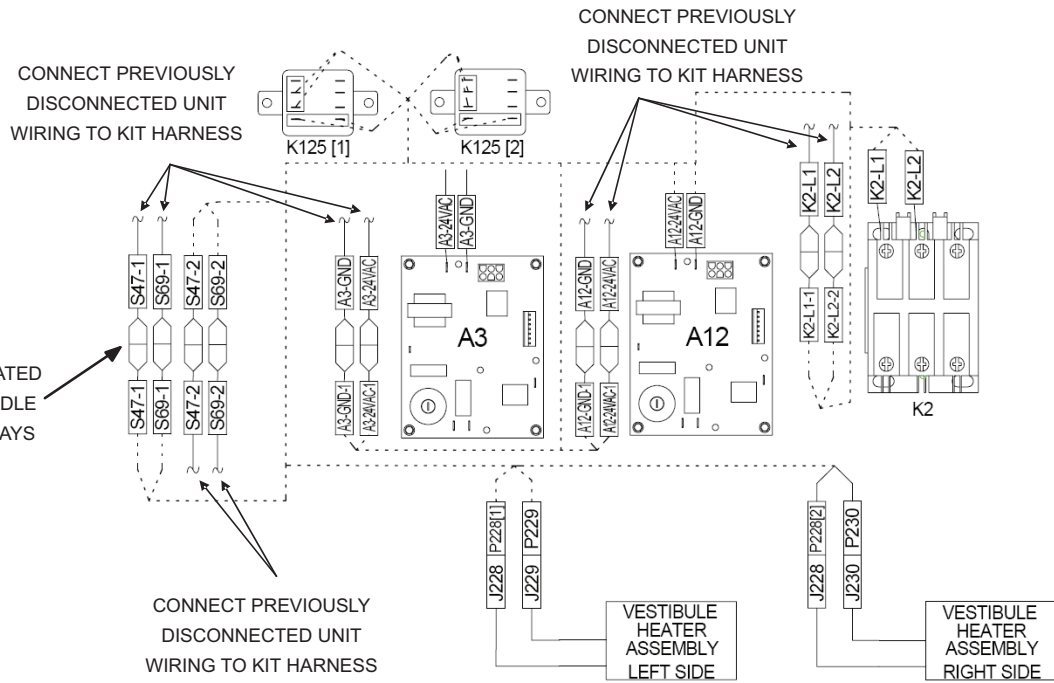
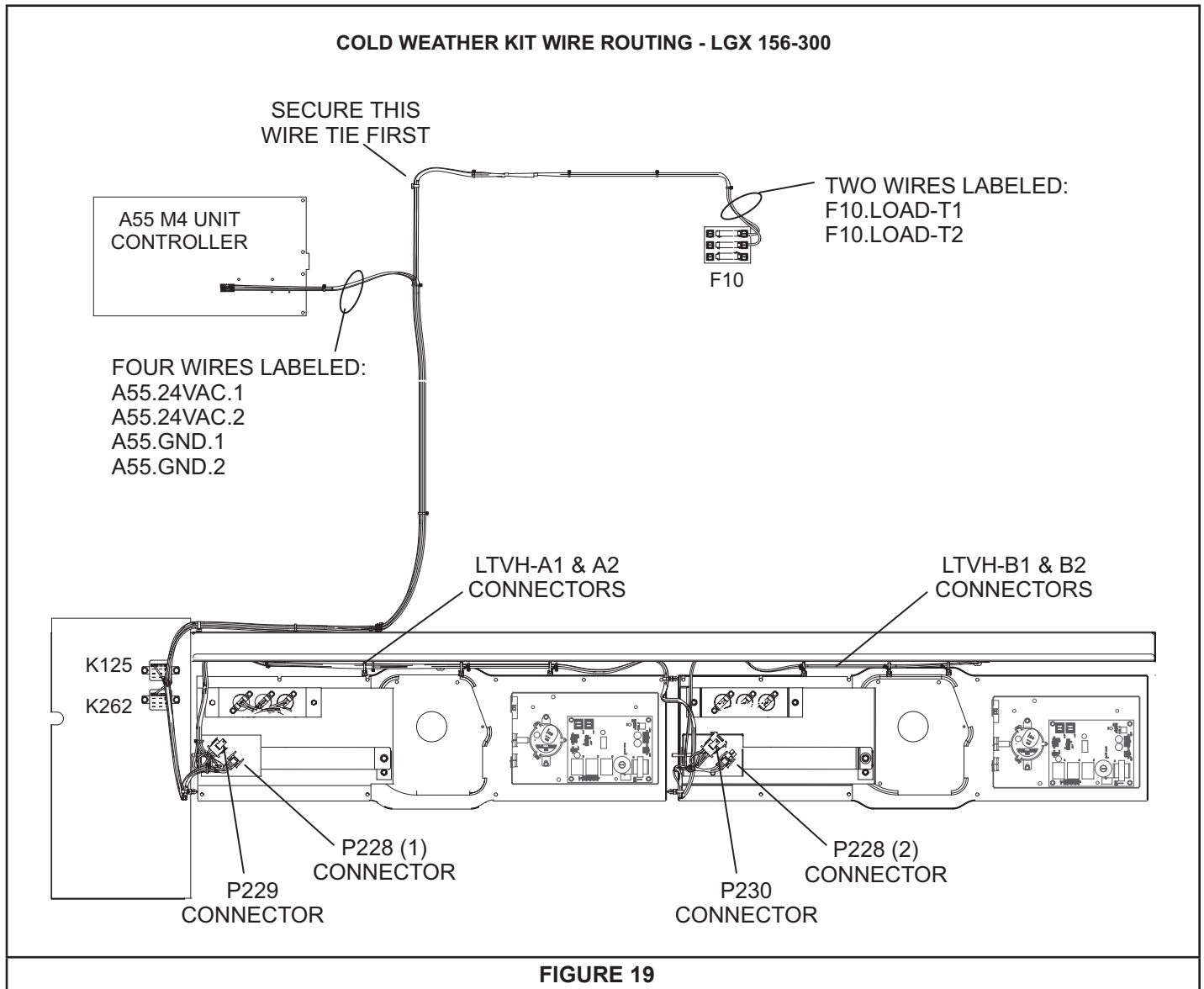


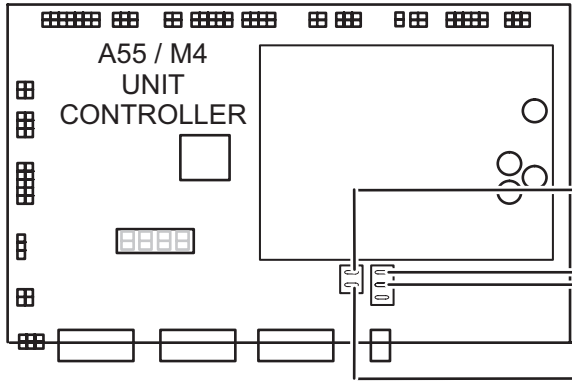
FIGURE 18

## Installation - LGX 156-300 Units

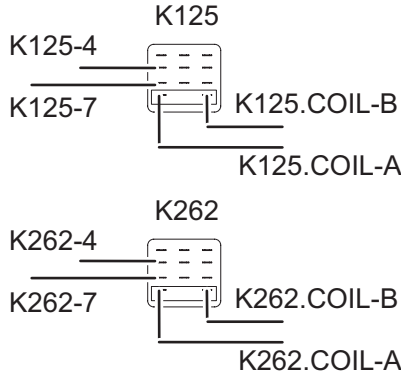
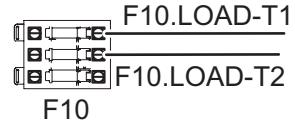
- 1 - Disconnect all power to unit and open heat access panel.
- 2 - Install both cold weather assemblies as shown in FIGURE 14. Use six thread forming screws, provided.
- 3 - Install both relays as shown in FIGURE 19. Secure with #8 screws.
- 4 - Locate harness labeled 106648-01. Route as shown in FIGURE 19. Secure with wire ties. Discard unused harnesses.
- 5 - Make wire connections as shown in FIGURE 20 and FIGURE 21.
- 6 - Use wire ties to securely route and tie harness away from gas heat manifold.



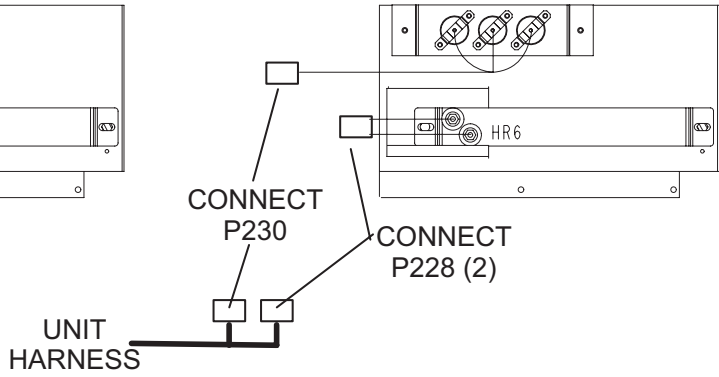
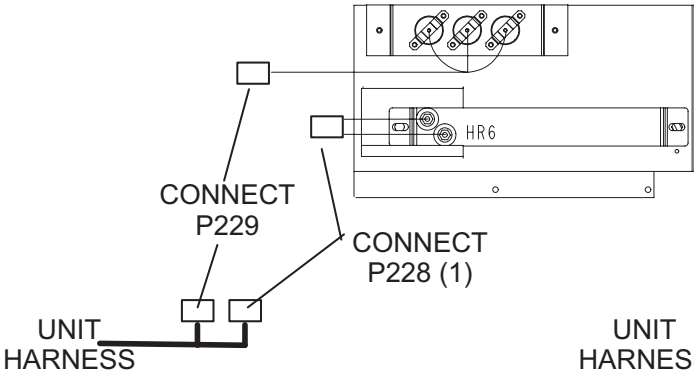
**COLD WEATHER KIT WIRING -  
LGX156-300**



A55.24VAC.1  
A55.GND.1  
A55.GND.2  
A55.24VAC.2

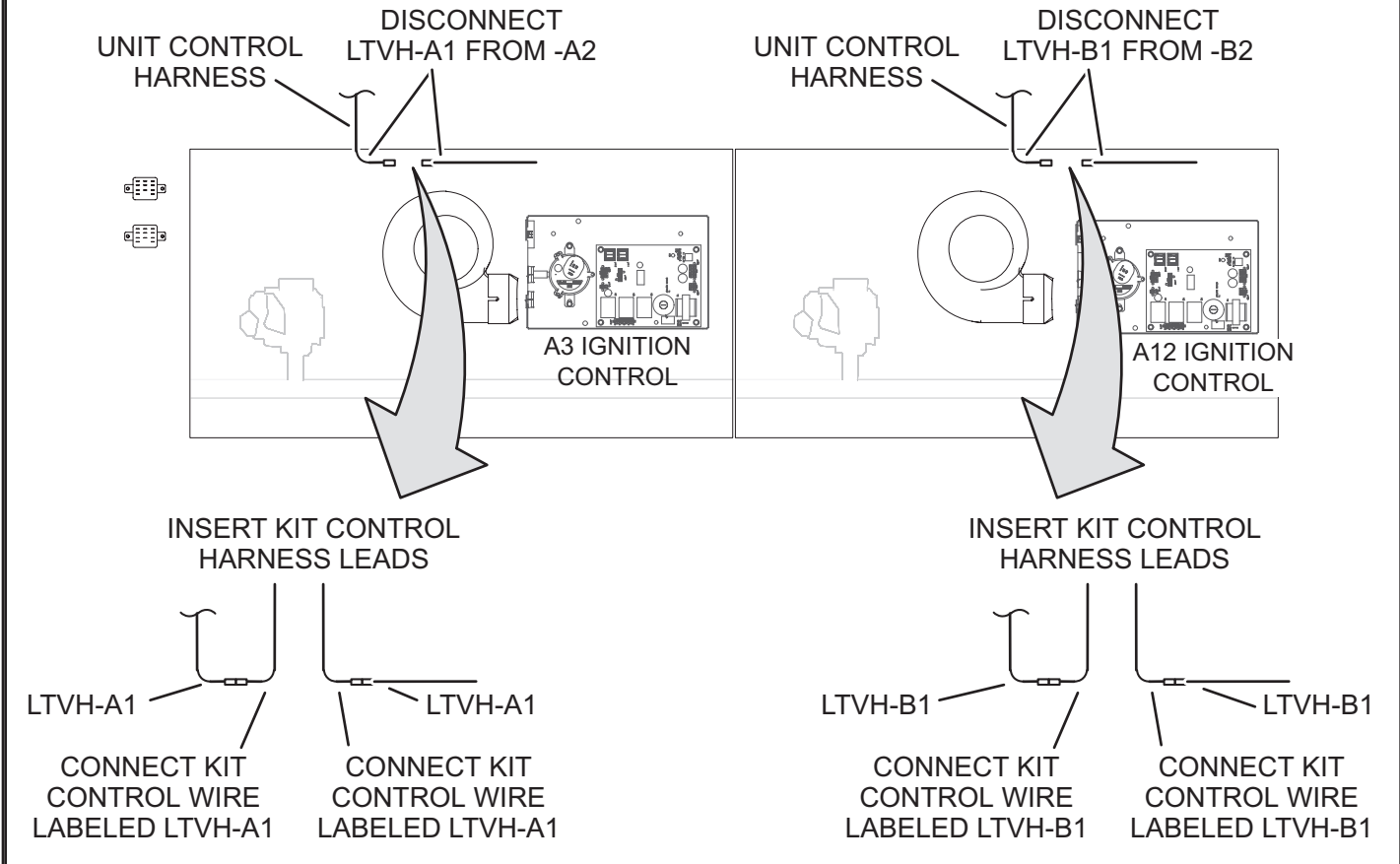


See figure 21 to connect control harness leads labeled:  
LTVH-A1  
LTVH-A2  
LTVH-B1  
LTVH-B2



**FIGURE 20**

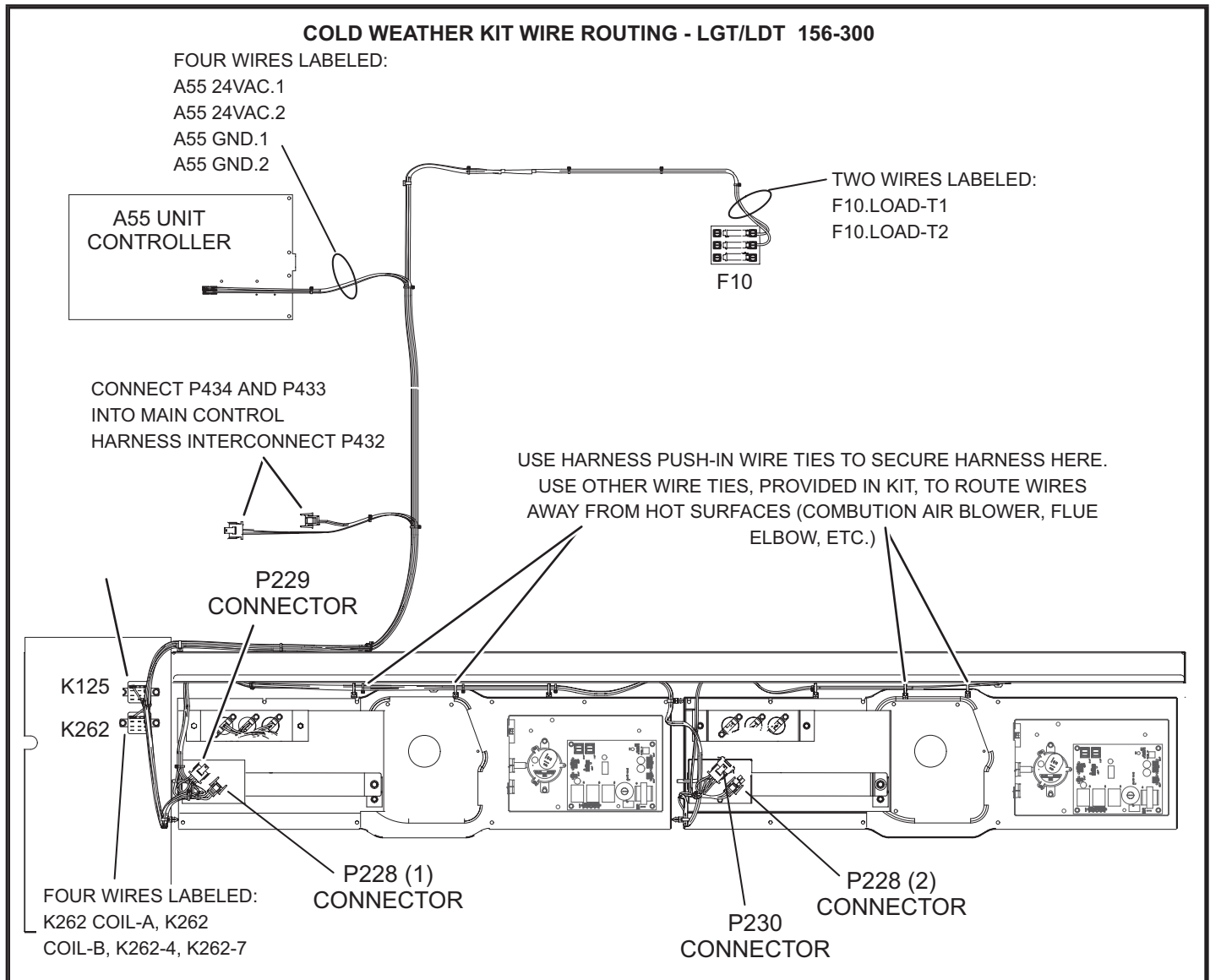
**COLD WEATHER KIT WIRING - (continued)**  
**LGX156-300**



**FIGURE 21**

## Installation - LGT/LDT 156-360 Units

- 1 - Disconnect all power to unit and open heat access panel.
- 2 - Install both cold weather assemblies as shown in FIGURE 14. Use six thread forming screws, provided.
- 3 - Install both relays as shown in FIGURE 22. Secure with #8 screws.
- 4 - Locate harness labeled 107210-01 (108303-01 for LGT/LDT 302-360). Route as shown in FIGURE 22. Secure with wire ties. Discard unused harnesses.
- 5 - Make wire connections as shown in FIGURE 22.
- 6 - Use wire ties to securely route and tie harness away from hot surfaces (collector box cover, combustion blower, flue elbow, etc.).



**FIGURE 22**



## Installation - SG 120 Unit

- 1 - Disconnect all power to unit and open control access panel, see FIGURE 23.
- 2 - Install the heater and control assembly in the control compartment as shown in FIGURE 9. Secure with provided screws.
- 3 - Look for the harness labelled 107824-01 (already in the unit). Disconnect connector from P432.
- 4 - Make wire connection as shown in FIGURE 24.

## Operation

When ambient temperature drops below 20°F (-7°C), S61 closes.

When ambient temperature drops below -10°F (-23°C), S60 closes to energize K125 and bring on HR6 heater.

When ambient temperature rises to 20°F (-7°C), S60 opens to de-energize HR6 heater.

When ambient temperature drops below -20°F (-29°C), S59 opens to disable GV1 gas valve.

S59 closes to allow heating when temperature rises to 10°F (-12°C).

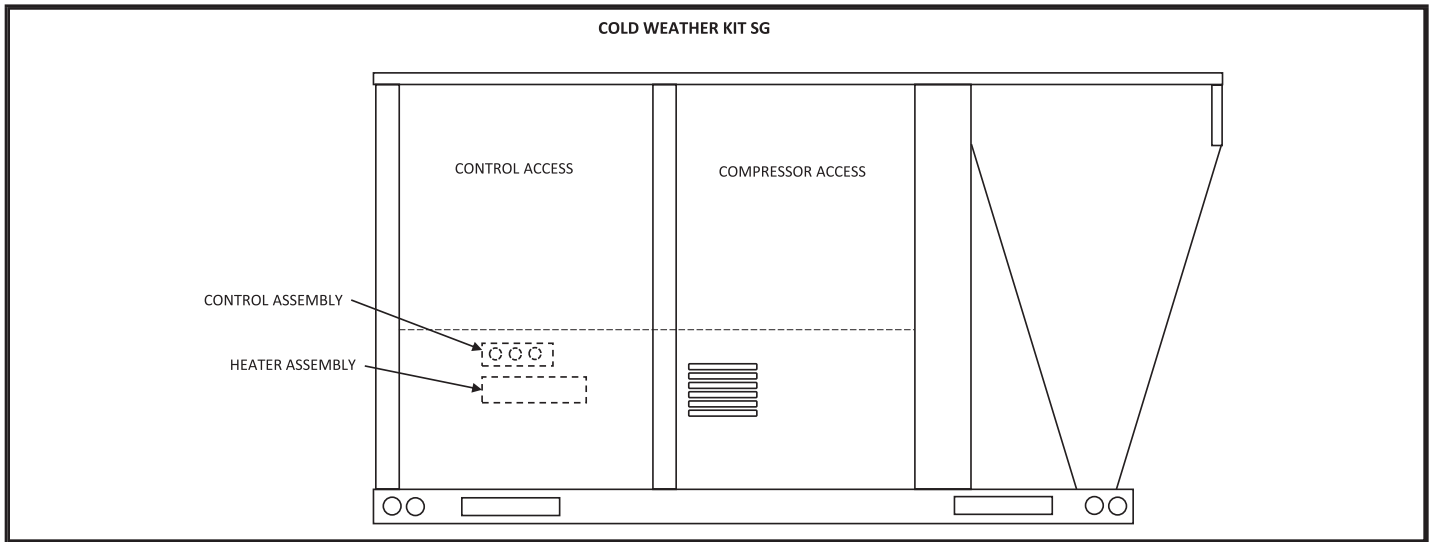


FIGURE 23

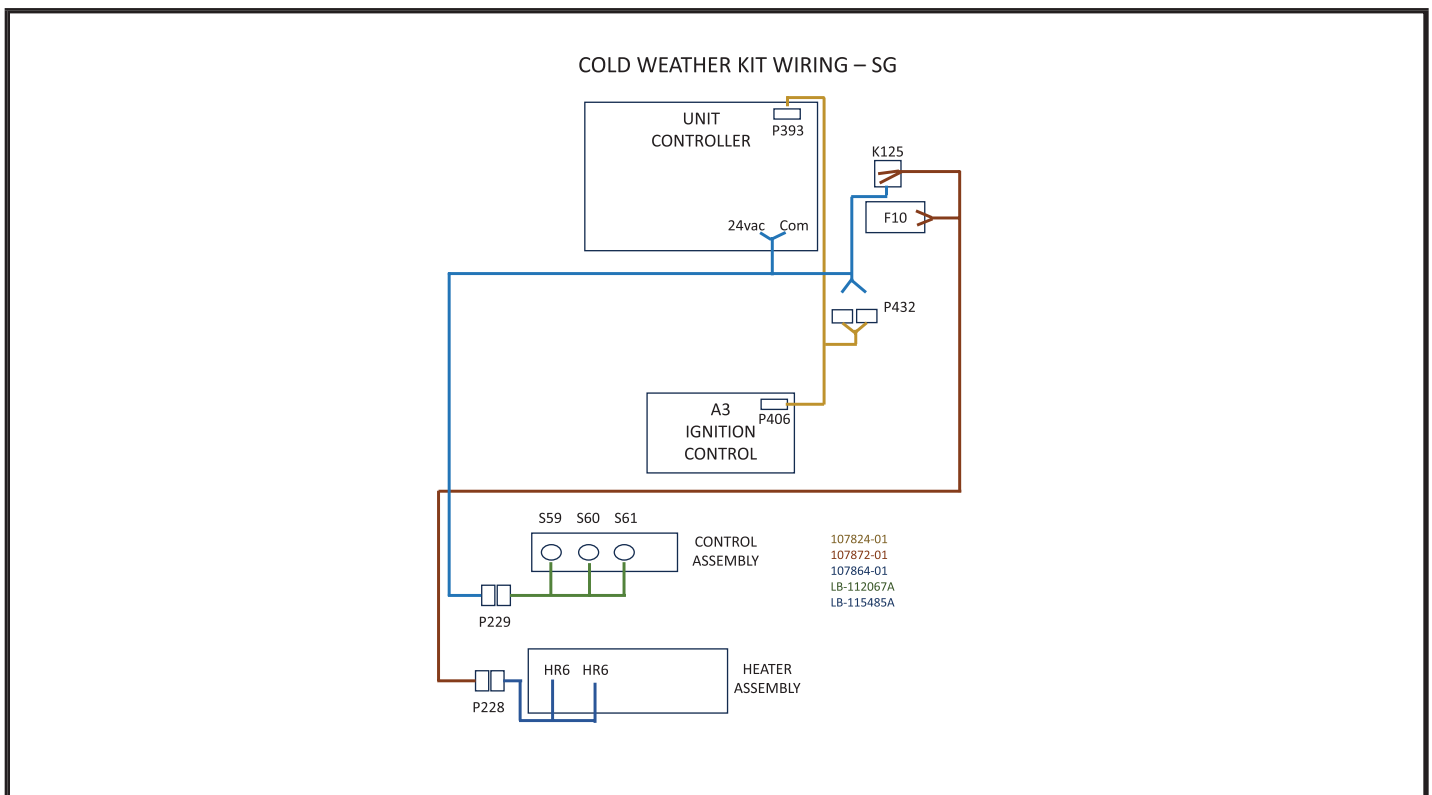


FIGURE 24