

INSTALLATION INSTRUCTIONS

AGENCY REQUIRED

RETAIN THESE INSTRUCTIONS FOR FUTURE REFERENCE



PACKAGED GAS UNITS

508461-01

6/2024

Supersedes 508110-01

LG/LD 036-360 UNITS

3 THROUGH 30 TONS

Table of Contents

| | |
|--|---|
| Safety | 1 |
| Connect Gas Piping | 3 |
| High Altitude Derate | 4 |
| Pressure Test Gas Piping | 4 |
| Two Stage Gas Valve Adjustment | 5 |
| Gas Heat Operation | 5 |
| Proper Gas Flow | 5 |
| Typical Gas Heat Schematic | 6 |
| Typical Unit Schematic | 7 |
| Repair Parts Listing | 8 |

Safety

⚠ WARNING

Improper installation, adjustment, alteration, service or maintenance can cause property damage, personal injury or loss of life. Installation and service must be performed by a licensed professional HVAC installer or equivalent, service agency, or the gas supplier.

Use of this unit as a construction heater or air conditioner is not recommended during any phase of construction. Very low return air temperatures, harmful vapors and operation of the unit with clogged or misplaced filters will damage the unit.

NOTE - On LD dual-fuel units, before making any adjustments, set outdoor thermostat setpoint above the outdoor ambient temperature. This will disable heat pump operation and allow gas heat operation.

If this unit has been used for heating or cooling of buildings or structures under construction, the following conditions must be met or the warranty will be void:

- The vent hood must be installed per these installation instructions.
- A room thermostat must control the unit. The use of fixed jumpers that will provide continuous heating or cooling is not allowed

- A pre-filter must be installed at the entry to the return air duct.
- The return air duct must be provided and sealed to the unit.
- Return air temperature range between 55°F (13°C) and 80°F (27°C) must be maintained.
- Air filters must be replaced and pre-filter must be removed upon construction completion.
- The input rate and temperature rise must be set per the unit rating plate.
- The heat exchanger, components, duct system, air filters and evaporator coil must be thoroughly cleaned following final construction clean-up.
- The unit operating conditions (including airflow, cooling operation, ignition, input rate, temperature rise and venting) must be verified according to these installation instructions.

NOTE - The Commonwealth of Massachusetts stipulates these additional requirements:

- **Gas units shall be installed by a licensed plumber or gas fitter only.**
- **The gas cock must be “T handle” type.**

The unit is certified for installation on noncombustible floors only. However, it may be installed on wood flooring, or on class A, class B, or class C material covered floors when used in horizontal discharge applications or in downflow discharge applications when mounted on an LARMF roof mounting frame.

Adequate clearance shall be provided around air openings into the vestibule area. Provisions shall be made for proper operation and for combustion air and ventilation air supply. Unit must be adjusted for the temperature rise range and within the allowable external static pressure on furnaces with a duct system as listed on unit nameplate.

United States

The unit is ETL/CSA certified for outdoor installations only at the clearances to combustible materials listed on the unit nameplate and in Figure 1, Figure 2 and Figure 3

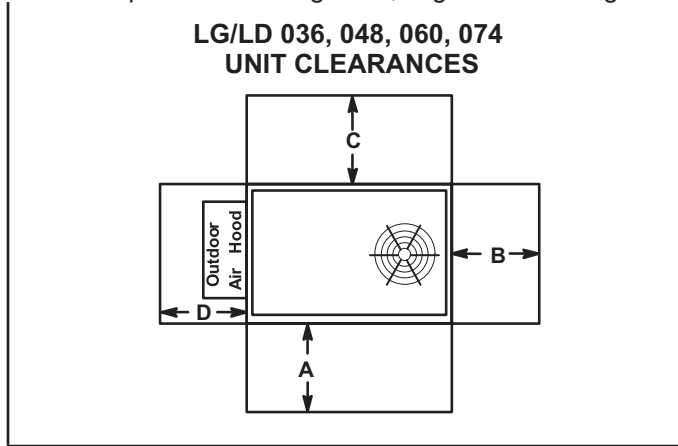

FIGURE 1

| ¹ Unit Clearance | A in.(mm) | B in.(mm) | C in.(mm) | D in.(mm) | Top Clearance |
|-----------------------------|-----------|-----------|-----------|-----------|---------------|
| Service Clearance | 48 (1219) | 36 (914) | 36 (914) | 36 (914) | Unobstructed |
| Clearance to Combustibles | 36 (914) | 1 (25) | 1 (25) | 1 (25) | Unobstructed |
| Minimum Operation Clearance | 36 (914) | 36 (914) | 36 (914) | 36 (914) | Unobstructed |

Note - Entire perimeter of unit base requires support when elevated above mounting surface.

¹Service Clearance - Required for removal of serviceable parts.

Clearance to Combustibles - Required clearance to combustible material.

Minimum Operation Clearance - Required clearance for proper unit operation.

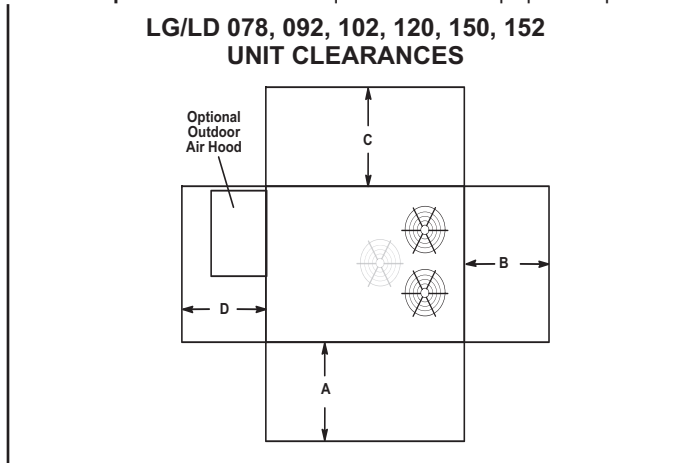

FIGURE 2

| ¹ Unit Clearance | A in.(mm) | B in.(mm) | C in.(mm) | D in.(mm) | Top Clearance |
|-----------------------------|-----------|-----------|-----------|-----------|---------------|
| Service Clearance | 60 (1524) | 36 (914) | 36 (914) | 60 (1524) | Unobstructed |
| Clearance to Combustibles | 36 (914) | 1 (25) | 1 (25) | 1 (25) | Unobstructed |
| Minimum Operation Clearance | 36 (914) | 36 (914) | 36 (914) | 36 (914) | Unobstructed |

Note - Entire perimeter of unit base requires support when elevated above mounting surface.

¹Service Clearance - Required for removal of serviceable parts.

Clearance to Combustibles - Required clearance to combustible material.

Minimum Operation Clearance - Required clearance for proper unit operation.

**LG/LD 156, 180, 210, 240, 360
UNIT CLEARANCES**

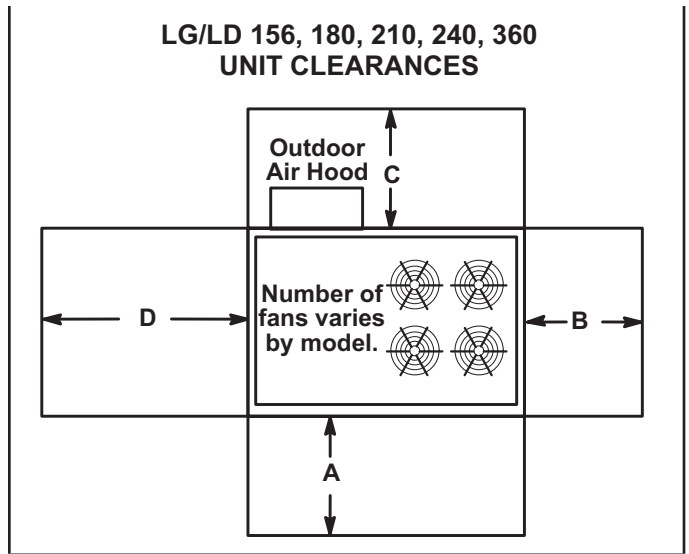

FIGURE 3

| ¹ Unit Clearance | A in.(mm) | B in.(mm) | C in.(mm) | D in.(mm) | Top Clearance |
|-----------------------------|-----------|-----------|-----------|-----------|---------------|
| Service Clearance | 60 (1524) | 36 (914) | 36 (914) | 66 (1676) | Unobstructed |
| Clearance to Combustibles | 36 (914) | 1 (25) | 1 (25) | 1 (25) | Unobstructed |
| Minimum Operation Clearance | 45 (1143) | 36 (914) | 36 (914) | 41 (1041) | Unobstructed |

Note - Entire perimeter of unit base requires support when elevated above mounting surface.

¹Service Clearance - Required for removal of serviceable parts.

Clearance to Combustibles - Required clearance to combustible material.

Minimum Operation Clearance - Required clearance for proper unit operation.

Installation of the ETL/CSA certified units must conform with local building codes. In the absence of local codes, units must be installed according to the current National Fuel Gas Code ANSI Z223.1/NFPA 54.

When installed, the unit must be electrically wired and grounded according to local codes or, in the absence of local codes, with the current National Electric Code, ANSI/NFPA 70.

The current American National Standard (ANSI Z223.1/NFPA 54) National Fuel Gas Code is available from the following address:

American National Standard Institute Inc.
11 West 42nd Street
New York, NY 10036

1 - The current National Electric Code (ANSI/NFPA 70) is available from the following address:

National Fire Protection Association
1 Batterymarch Park
PO Box 9101
Quincy, MA 02269-9101

Use only the type of gas approved for use with this furnace. Refer to unit nameplate.

Never test for gas leaks with an open flame. Check all connections with a commercially available soap solution made specifically for leak detection.

NOTE - Furnace must be adjusted to obtain a temperature rise (high and low fire) within the range(s) specified on the unit nameplate. Failure to do so may cause erratic limit operation.

Canada

The unit is CSA International (CSA) certified for combination heating/cooling for outdoor installations and non-residential use only at the clearances to combustible materials as listed on the unit nameplate.

Installation of CSA international certified units must conform with current standard CSA B149.1, "Natural Gas and Propane Installation Codes" and applicable local codes. Authorities having jurisdiction should be consulted before installation.

The unit must be wired and electrically grounded according to local codes or, in the absence of local codes, current CSA Standard C22.1 Canadian Electrical Code Part 1. Installation of combination heating/cooling units must also conform with current CSA Standard B52 "Mechanical Refrigeration Code."

Connect Gas Piping

A manual main shut-off valve must be installed external to the unit when local codes require the installation of such a valve.

Install a ground joint union between the gas control manifold and the main manual shut-off valve.

When making piping connections a drip leg should be installed on vertical pipe runs to serve as a trap for sediment or condensate.

A 1/8" N.P.T. plugged tap is located on gas valve for test gauge connection. See Figure 4, Figure 5, and Figure 6 for tap location. See Figure 7 for gas supply piping entry through the side of the unit and Figure 8 for gas piping through the bottom of the unit. A kit is required when routing gas supply piping through the bottom of the unit.

Compounds used on threaded joints of gas piping must be resistant to the actions of liquified petroleum gases.

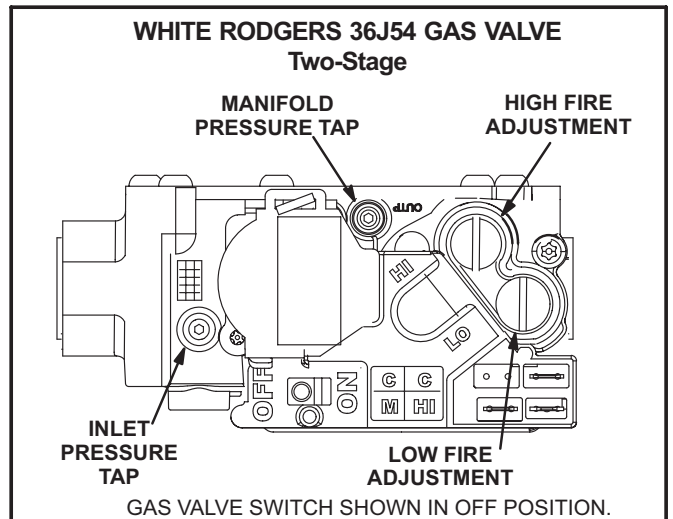

FIGURE 4

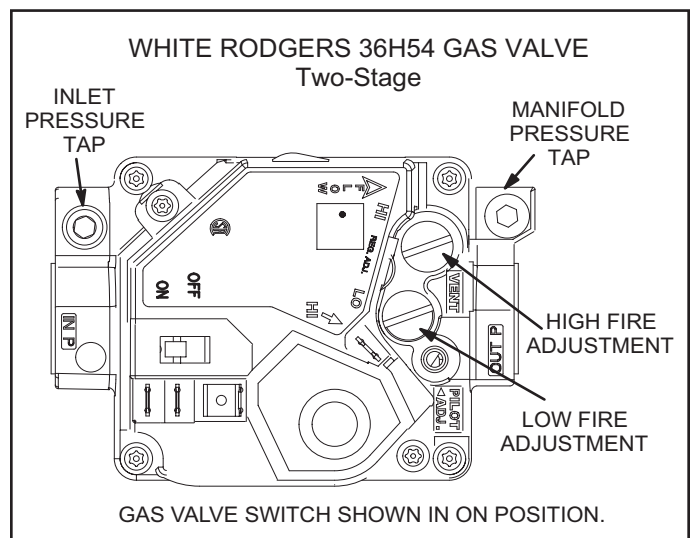

FIGURE 5

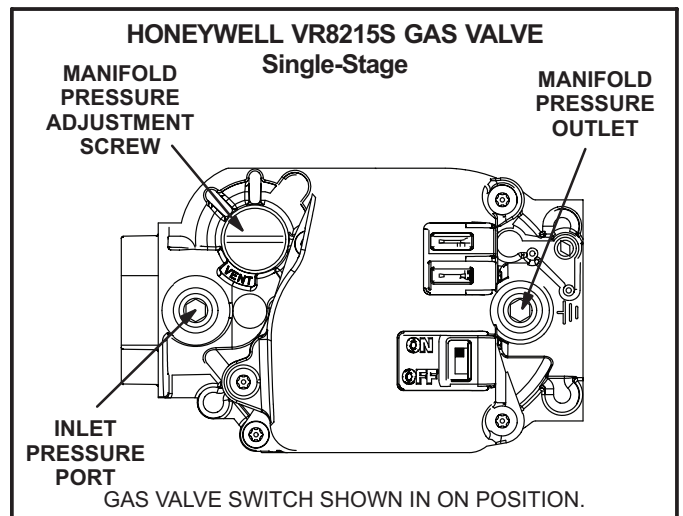

FIGURE 6

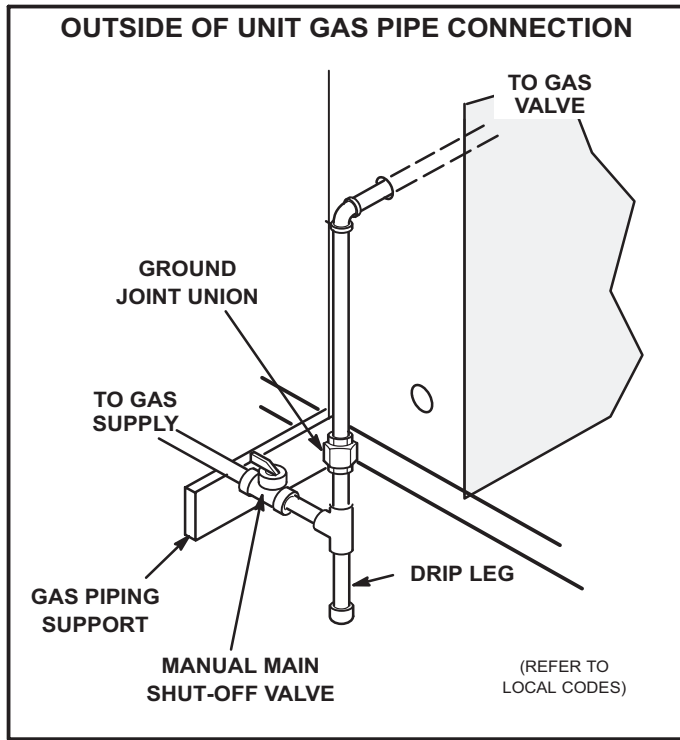

FIGURE 7

High Altitude Derate - Non-ULNOx

Locate the high altitude conversion sticker in the unit literature bag. Fill out the conversion sticker and affix next to the unit nameplate.

Refer to TABLE 1 for high altitude adjustments.

**TABLE 1
HIGH ALTITUDE DERATE**

| Unit | Altitude Ft.* | Gas Manifold Pressure |
|---------|----------------|--------------------------------------|
| All | 2000-4500 | See Unit Nameplate |
| 036-074 | 4500 And Above | Derate 2% / 1000 Ft. Above Sea Level |
| 078-152 | 4500 And Above | Derate 4% / 1000 Ft. Above Sea Level |
| 156-360 | 4500 And Above | Derate 4% / 1000 Ft. Above Sea Level |

*Units installed at 0-2000 feet do not need to be modified.

NOTE - This is the only permissible derate for these units.

High Altitude Derate - ULNOx

Ultra-Low NOx units are approved for installations from 0 - 4500 ft. No modifications are required. Above 2000 ft, the furnace will naturally derate approximately 10%.

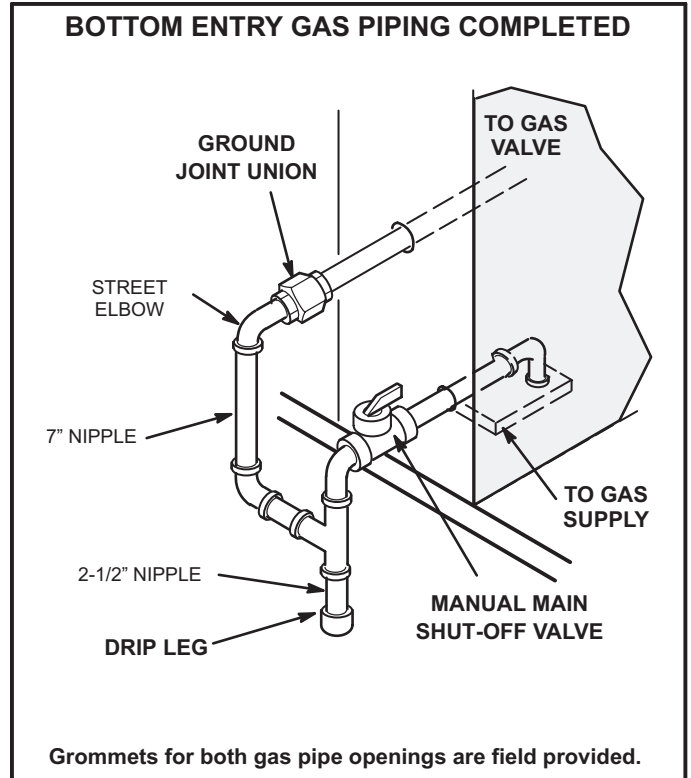

Grommets for both gas pipe openings are field provided.

FIGURE 8

Pressure Test Gas Piping

Operating pressures at the unit gas connection must be as shown in TABLE 2.

**TABLE 2
OPERATING PRESSURE AT GAS CONNECTION "w.c"**

| Model | Natural Gas | | LP/ Propane Gas | |
|---------|-------------|------|-----------------|------|
| | Min. | Max. | Min. | Max. |
| 036-074 | 4.5 | 10.5 | 10.8 | 13.5 |
| 078-360 | 4.7 | 10.5 | 10.8 | 13.5 |

When testing the pressure of gas lines, the gas valve must be disconnected and isolated. Gas valves can be damaged if subjected to more than 0.5 psig.

⚠ WARNING

FIRE OR EXPLOSION HAZARD Failure to follow the safety warnings exactly could result in serious injury, death or property damage. Never test for gas leaks with an open flame. Use a commercially available soap solution made specifically for the detection of leaks to check all connections. A fire or explosion may result causing property damage, personal injury or loss of life.

Two-Stage Gas Valve Adjustment

Gas manifold pressures should match pressures shown in TABLE 3. On two stage gas valves, initiate a W2 thermostat demand to check high fire pressure before low fire pressure. With high fire operating, reduce the thermostat demand to W1 and check the low fire pressure. Refer to the Unit Controller manual to initiate a thermostat demand.

IMPORTANT - Do not set low fire pressure lower than the certified minimum input rating listed in TABLE 3.

TABLE 3
MANIFOLD INPUT PRESSURES in.wg. (kPa)

| Unit | Natural Gas | | Propane (LP)Gas | |
|--------------------------------------|-----------------|-------------------|-----------------|-------------------|
| | 1st Stg ±0.2 | 2nd Stg ± 0.3. | 1st Stg ±0.2 | 2nd Stg ± 0.3. |
| 024, 036, 048, 060, 074 Dual Heat | 2.0 | 3.5 | 5.9 | 10.5 |
| 078-300 | 1.6 | 3.7 | 5.5 | 10.5 |

Gas Heat Operation - Non-ULNOx Units

See the operating instruction plate on the unit for details.

Gas Heat Operation - ULNOx Units

Manifold Pressure

Use the following steps to correctly measure manifold pressure:

- 1- Remove the threaded plug from the outlet side of the gas valve and install a field-provided barbed fitting. Connect measuring device "+" connection to barbed fitting to measure manifold pressure. Start unit and allow 15 minutes for unit to reach steady state.
- 2- After allowing unit to stabilize for 15 minutes, record manifold pressure and compare to value given in TABLE 4. Normally manifold adjustment is not necessary; adjust manifold only if needed.
- 3- Shut unit off and remove manometer as soon as an accurate reading has been obtained.

TABLE 4
MANIFOLD PRESSURE (in.w.c.)

| | |
|-----------|----------|
| High Fire | 3.2-3.6. |
| Low Fire | 1.7-2.1 |

Proper Combustion

Restart unit and check for any gas leaks. Seal any leaks if found. Furnace should operate minimum 15 minutes with correct manifold pressure and gas flow rate before checking combustion. TABLE 5 shows acceptable combustion. The maximum carbon monoxide reading should not exceed 100 ppm.

TABLE 5
CO₂ RATES (ppm)

| | |
|-----------|----------------------------------|
| High Fire | 6.0-7.5 |
| Low Fire | 6.0-7.5 (CO ₂ tracks) |

ULNOx units are not equipped with gas orifices that supply each burner. Instead, a single gas orifice supplies gas to the air/gas elbow. An intake air orifice supplies combustion air to the air/gas elbow. The combustion air blower draws the air/gas mixture from the air/gas elbow into the air/gas plenum box. When the spark ignites the gas, the ignition sensor proves the flame and combustion occurs in the burner premix plate. The burner box liner directs the flames into the burner tube sleeves.

Proper Gas Flow (Approximate)

- 1- Operate unit at least 15 minutes before checking gas flow. Determine the time in seconds for two revolutions of gas through the meter. (Two revolutions assures a more accurate time.) A portable LP gas meter (17Y44) is available for LP applications.
- 2- Divide the number of seconds by two and compare to the time in TABLE 6. If manifold pressure is correct and rate is incorrect, check gas orifices for proper size and restriction.
- 3- Remove temporary gas meter if installed.

NOTE - To obtain accurate reading, shut off all other gas appliances connected to meter.

TABLE 6
GAS METER CLOCKING CHART

| Unit Input Rate (Btuh) | Seconds for One Revolution | | | |
|---------------------------------|----------------------------|--------------------------|-----------------|-----------------|
| | Natural | | LP | |
| | 1 cu ft Dial | 2 cu ft Dial | 1 cu ft Dial | 2 cu ft Dial |
| 60,000 | 60 | 150 | 120 | 300 |
| 65,000 | 55 | 111 | 138 | 277 |
| 70,000 | 51 | 103 | 129 | 257 |
| 100,000 | 36 | 90 | 72 | 180 |
| 108,000 | 33 | 67 | 83 | 167 |
| 130,000 | 28 | 55 | 69 | 138 |
| 150,000 | 24 | 48 | 60 | 120 |
| 169,000 | 21 | 43 | 53 | 107 |
| 180,000 | 20 | 40 | 50 | 100 |
| 240,000 | 15 | 30 | 38 | 75 |
| 260,000 | 14 | 28 | 35 | 69 |
| 360,000 | 10 | 20 | 30 | 50 |
| 480,000 | 8 | 15 | 19 | 38 |
| Natural-1000 btu/cu ft | | LP-2500 btu/cu ft | | |

NOTE - Table assumes standard temperature (60°F), pressure (30in.Hg.), and fuel heating values (Btuh/Ft.3). Apply pressure corrections in altitudes above 2000 ft.

Typical Gas Heat Schematic

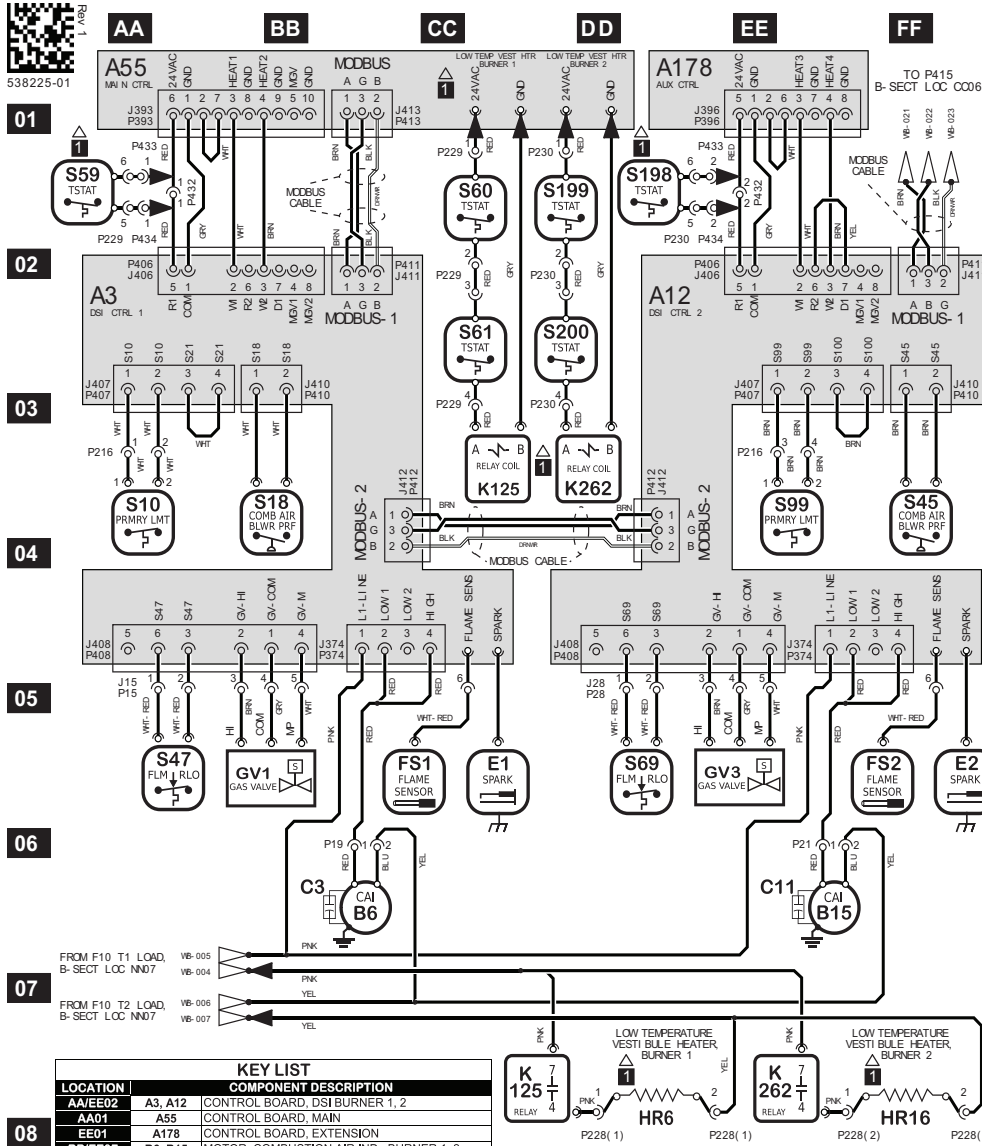

KEY LIST

| LOCATION | COMPONENT DESCRIPTION |
|----------|---|
| AA/EE02 | A3, A12 CONTROL BOARD, DSI BURNER 1, 2 |
| AA01 | A55 CONTROL BOARD, MAIN |
| EE01 | A178 CONTROL BOARD, EXTENSION |
| BB/EE07 | B6, B15 MOTOR, COMBUSTION AIR IND., BURNER 1, 2 |
| BB/EE06 | C3, C11 CAPACITOR, CAI MOTOR 1, 2 |
| CC/FF06 | E1, E2 IGNITER, SPARK, BURNER 1, 2 |
| CC/FF06 | FS1, FS2 SENSOR, FLAME, BURNER 1, 2 |
| BB/EE06 | GV1, GV2 VALVE, GAS, BURNER 1, 2 |
| DD/FF08 | HR6, HR16 HEATER, -50C LOW TEMP VEST. BURNER 1, 2 |
| CC/DD03 | K125, K262 RELAY, LOW TEMP VEST HEATER, BURNER 1, 2 |
| DD/EE08 | K125, K262 RELAY, LOW TEMP VEST HEATER, BURNER 1, 2 |
| AA/EE04 | S10, S99 LIMIT, PRIMARY, BURNER 1, 2 |
| BB/FF04 | S18, S45 SWITCH, COMB AIR BLWR PROOF, BURNER 1, 2 |
| AA/DD06 | S47, S69 SWITCH, FLAME ROLLOUT, BURNER 1, 2 |
| AA/DD02 | S59, S198 TSTAT, OPEN 20F, CLOSE 10F, BURNER 1, 2 |
| CC/DD02 | S60, S199 TSTAT, OPEN 20F, CLOSE 10F, BURNER 1, 2 |
| CC/DD03 | S61, S200 TSTAT, OPEN 50F, CLOSE 20F, BURNER 1, 2 |

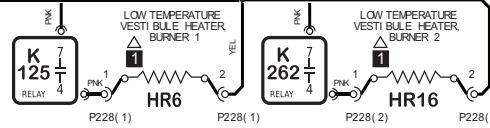

NOTES
 1 -50C LOW TEMPERATURE VESTIBULE HEATER - OPTIONAL

← DENOTES OPTI ONAL COMPONENTS AND W I R I N G

10 Model: LG, LD, SG Series RTU - Gas Heat
 Input Heat Capacity 169k - 480k BtuH
 Voltage: 208-240V/3~60Hz (Y), 460V/3~60Hz (G)
 Supersedes: N/A Form No: 538225- 01 Rev: 1

© 2019

| | | | | |
|-----------|-----------|------------|-----------|-----------|
| HEATING | COOLING | COOLING | ACCS | ACCS |
| SECTION A | SECTION B | SECTION B3 | SECTION C | SECTION D |

WIRING DIAGRAM FLOW

7x10
 CUT
 SIZE

| REV | EC NO. | DATE | BY | APVD | REVISION NOTE |
|-----|------------|------------|------|-------|--|
| --- | CN-010356 | 06-21-2022 | MXR6 | JAL21 | ORIGINATED AT PD&R CARROLLTON, TX |
| 001 | CN-012295C | 04-03-2024 | MXR6 | MXT5 | A) REVISED CAI B6/B15 SYMBOL B) ADDED SG MODEL TO TITLE BLOCK. |

Typical Unit Schematic

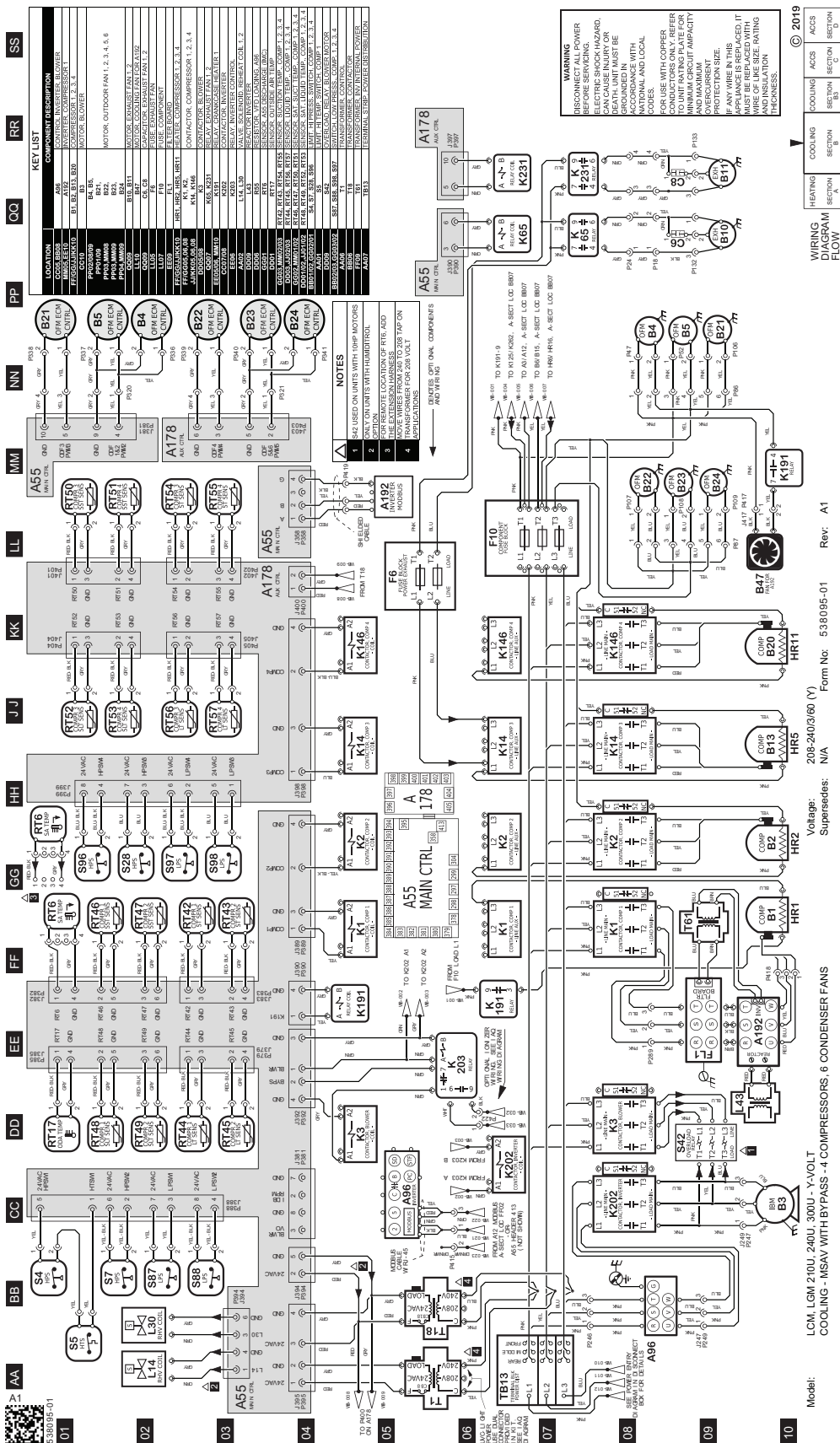

Repair Parts Listing

When ordering repair parts, include the complete model number and serial number listed on the ETL/CSA rating plate - e.g. LGT120H4EH1Y.

Gas Heat Section Parts

Heat Exchanger
Combustion Air Assembly
Combustion Air Proving Switch
Burner Assembly
Burner Manifold Assembly
Main Burner Orifices
Flame Roll-out Switches
Auxiliary Limit Controls
Ignition Electrode Assembly
Ignition Lead
Ignition Sensor Assembly
Sensor Lead
Combination Gas Valve
Limit Controls
Ignition Controller

Cooling Parts

Compressors
Condenser Fan Motors
Condenser Fan Blades
Condenser Fan Run Capacitors*
*Used only with PSC motor applications
Condenser Fan Mounting Bracket
Fan Grille
Indoor Blower Motors
Blower Wheel
Expansion Valve
Distributor
Exhaust Fans (Opt.)
Reversing Valve (LD and reheat units only)

Electrical Control Parts

Compressor Contactors
Circuit Breakers (Opt.)
Transformer (Control)
Transformer (Contactor)
Blower Contactor
Limit, Blower Relay
Heat Relays
Condenser Fan Relays
Capacitor CAB
Relay CAB
Disconnect Switch (Opt.)
Defrost Control (LD only)
Fan Control Board (LD only)

ULNOx Units

Intake Air Screen
Intake Air Orifice
Air/Gas Elbow
Air/Gas Plenum Box
Burner Premix Plate
Burner Box Liner and Tubes
Inlet Reducer
Rubber Coupling