

# INSTALLATION INSTRUCTIONS

**⚠ IMPORTANT**  
 Improper installation, adjustment, alteration, service or maintenance can cause property damage, personal injury or loss of life. Installation and service must be performed by a licensed professional HVAC installer or equivalent, service agency, or the gas supplier

**⚠ WARNING**  
 As with any mechanical equipment, contact with sharp sheet metal edges can result in personal injury. Take care while handling this equipment and wear gloves and protective clothing.

Table of Contents	
Dimensions . . . . .	4
Parts Arrangements . . . . .	6
Shipping and Packing List . . . . .	7
General . . . . .	7
Requirements . . . . .	7
Unit Support . . . . .	8
Duct Connection . . . . .	9
Rigging Unit for Lifting . . . . .	9
Condensate Drains . . . . .	9
Connect Gas Piping. . . . .	10
Pressure Test Gas Piping . . . . .	10
High Altitude Derate . . . . .	11
Electrical Connections - Power Supply . . . . .	11
Electrical Connections - Control Wiring. . . . .	12
Mobile Service App . . . . .	14
Blower Operation and Adjustments . . . . .	16
Refrigerant Leak Detection System . . . . .	23
Cooling Start-Up. . . . .	23
Diagnostic Sensors . . . . .	53
RDS Sensors. . . . .	57
Gas Heat Start-Up (Gas Units) . . . . .	59

- LGM/LCM156U** (13 TON)
- LGM/LCM180U** (15 TON)
- LGM/LCM210U** (17.5 TON)
- LGM/LCM240U** (20 TON)
- LGM/LCM300U** (25 Ton)

**ROOFTOP PACKAGED UNITS**

508465-01  
 10/2024

**R-454B**

Heating Operation and Adjustments . . . . .	60
Electric Heat Start-Up (LCM Units) . . . . .	60
Variable Air Volume Start-Up. . . . .	61
Multi-Stage Air Volume Start-Up . . . . .	63
Multi-Stage Air Volume Operation . . . . .	65
Hot Gas Reheat Start-Up and Operation . . . . .	66
Preventative Maintenance / Repair . . . . .	70
Factory Unit Controller Settings . . . . .	79
Decommissioning. . . . .	79

**⚠ WARNING**  
**To prevent serious injury or death:**  
 1- **Lock-out, tag-out before performing maintenance.**  
 2- **If system power is required (e.g., smoke detector maintenance), disable power to blower, remove fan belt where applicable, and ensure all controllers and thermostats are set to the OFF position before performing maintenance.**  
 3- **Always keep hands, hair clothing, jewelry, tools, etc., away from moving parts.**

**RETAIN THESE INSTRUCTIONS FOR FUTURE REFERENCES**

Attention!

Use this QR code to download the mobile service app. Follow the prompts to pair the app with the Unit Controller. Refer to the “Mobile Service App” section in this manual. The QR code is also available in the unit control area.



The app can be downloaded from the appropriate iOS or Android store. Look for the following icon.



## CAUTION

As with any mechanical equipment, contact with sharp sheet metal edges can result in personal injury. Take care while handling this equipment and wear gloves and protective clothing.

## WARNING

Only manufacturer approved auxiliary devices are permitted to be installed in this unit.

## WARNING

If this appliance is conditioning a space with an area smaller than T<sub>Amin</sub> or stored in a space with an area smaller than A<sub>min</sub> as defined by this instruction, then that space must be without continuously operating open flames (e.g. an operating gas appliance) or other potential ignition sources (e.g. an operating electric heater or similar hot surface). A flame-producing device may be installed in the same space if the device is provided with an effective flame arrest system.

## CAUTION

Auxiliary devices which may be a potential ignition source shall not be installed in the duct work. Examples of such potential ignition sources are hot surfaces with a temperature exceeding 700°C and electric switching devices.

## CAUTION

The appliance is not to be used by persons (including children) with reduced physical, sensory or mental capabilities, or lack of experience and knowledge, unless they have been given supervision or instruction.

## CAUTION

Children should be supervised not to play with the appliance.

## CAUTION

Servicing shall be performed only as recommended by the manufacturer.

## CAUTION

Any personnel installing, decommissioning, or performing maintenance on the unit must be properly trained with A2L refrigerants.

## WARNING

•This appliance must be installed in accordance with local and national wiring regulations.

•If the appliance is not fitted with an option for full disconnection from power, a means of disconnection must be incorporated in the fixed wiring in accordance with national and local wiring regulations.

## CAUTION

Leak Detection System installed. Unit must be powered except for service.

## WARNING

•Do not use means to accelerate the defrosting process or to clean, other than those recommended by the manufacturer.

•The appliance shall be stored in a room without continuously operating ignition sources (for example: open flames, an operating gas appliance, or an operating electric heater).

•Do not pierce or burn.

•Be aware that refrigerants may not contain an odor

## WARNING

Ducts connected to an appliance shall not contain a potential ignition source.

## IMPORTANT

Pipe work, including piping material, pipe routing, and installation shall include protection from physical damage in operation and service, and be in compliance with national and local codes and standards, such as ASHRAE 15, ASHRAE 15.2, IAPMO Uniform Mechanical Code, ICC International Mechanical Code, or CSA B52. All field joints shall be accessible for inspection prior to being covered or enclosed.

## IMPORTANT

Refrigerant sensors for refrigerant detection systems shall only be replaced with sensors specified by the appliance manufacturer.

## CAUTION

This unit is equipped with electrically powered safety measures. To be effective, the unit must be electrically powered at all times after installation, other than when servicing.

## **A2L Refrigerant Considerations**

Ensure that the area is in the open or that it is adequately ventilated before breaking into the system or conducting any hot work. A degree of ventilation shall continue during the period that the work is carried out. The ventilation should safely disperse any released refrigerant and preferably expel it externally into the atmosphere.

Check that cabling will not be subject to wear, corrosion, excessive pressure, vibration, sharp edges or any other adverse environmental effects, taking into account the effects of aging or continual vibration from sources such as compressors or fans.

Under no circumstances shall potential sources of ignition be used when searching for or detection of refrigerant leaks. A halide torch (or any other detector using a naked flame) shall not be used. Electronic leak detectors may be used to detect refrigerant leaks but, in the case of flammable refrigerants, the sensitivity may not be adequate, or may need re-calibration. (Detection equipment shall be calibrated in a refrigerant-free area.) Ensure that the detector is not a potential source of ignition and is suitable for the refrigerant used. Leak detection equipment shall be set at a percentage of the LFL of the refrigerant and shall be calibrated to the refrigerant employed, and the appropriate percentage of gas (25 % maximum) is confirmed. Leak detection fluids are also suitable for use with most refrigerants but the use of detergents containing chlorine shall be avoided as the chlorine may react with the refrigerant and corrode the copper pipe-work. If a leak is suspected, all naked flames shall be removed/extinguished. If a leakage of refrigerant is found which requires brazing, all of the refrigerant shall be recovered from the system, or isolated (by means of shut off valves) in a part of the system remote from the leak.

When breaking into the refrigerant circuit to make repairs – or for any other purpose – conventional procedures shall be used. However, for flammable refrigerants it is important that best practices be followed since flammability is a consideration. The following procedure shall be adhered to:

- Safely remove refrigerant following local and national regulations.

- Evacuate the circuit.

- Purge the circuit with inert gas.

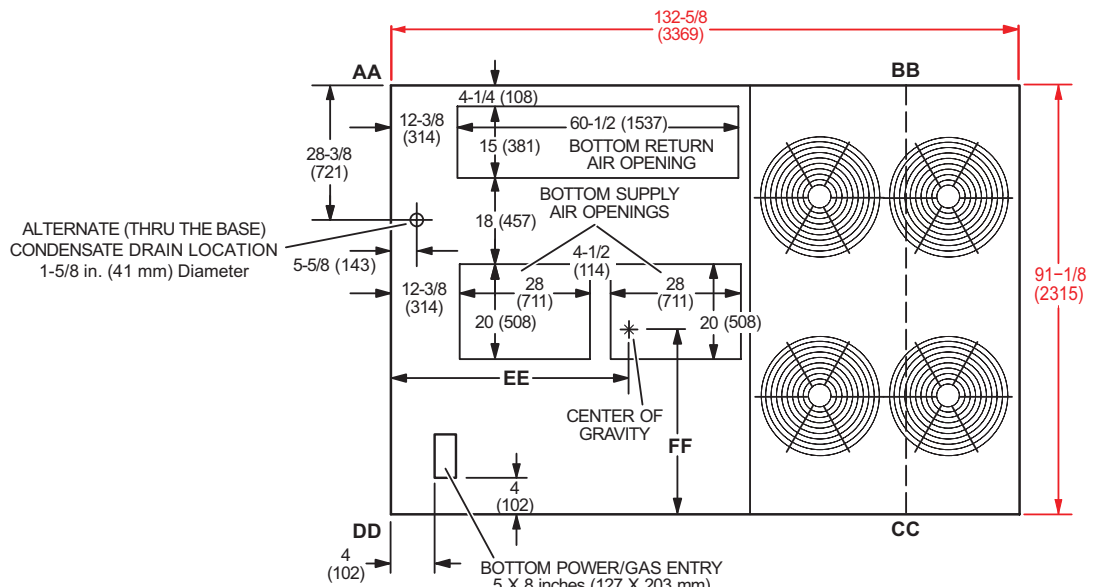
- Evacuate.

- Purge the circuit with inert gas.

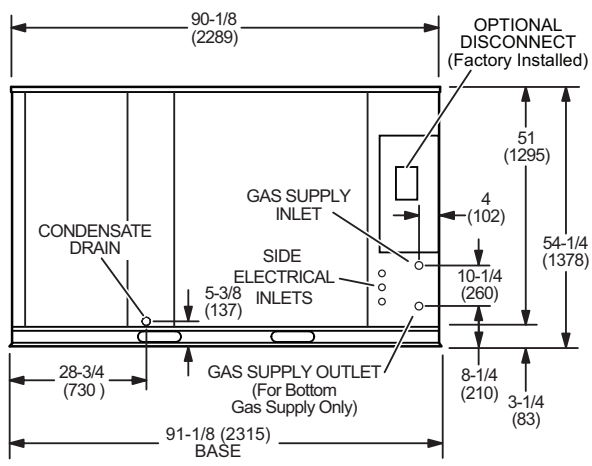
- Open the circuit

The refrigerant charge shall be recovered into the correct recovery cylinders if venting is not allowed by local and national codes. For appliances containing flammable refrigerants, the system shall be purged with oxygen-free nitrogen to render the appliance safe for flammable refrigerants. This process might need to be repeated several times. Compressed air or oxygen shall not be used for purging refrigerant systems. Refrigerants purging shall be achieved by breaking the vacuum in the system with oxygen-free nitrogen and continuing to fill until the working pressure is achieved, then venting to atmosphere, and finally pulling down to a vacuum. This process shall be vented down to atmospheric pressure to enable work to take place. Ensure that the outlet for the vacuum pump is not close to any potential ignition sources and that ventilation is available.

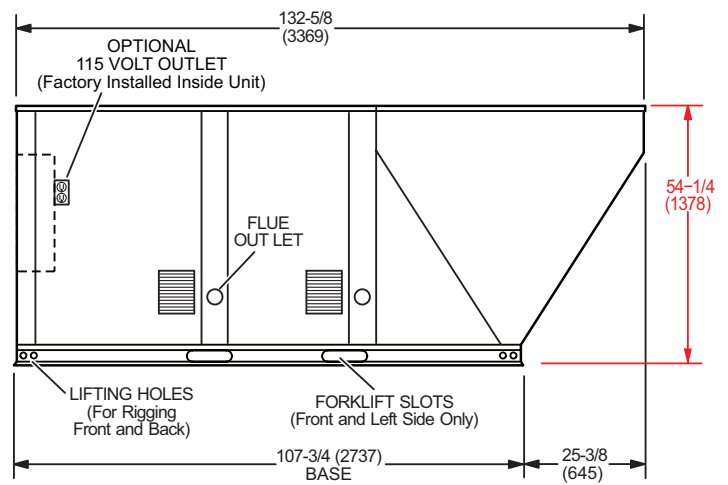
**LGM/LCM156U, 180U DIMENSIONS in. (mm) - Gas heat section shown**



**TOP VIEW**

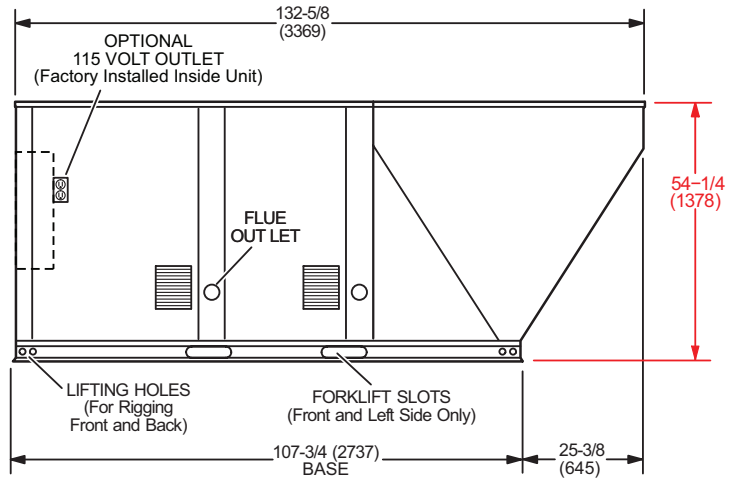
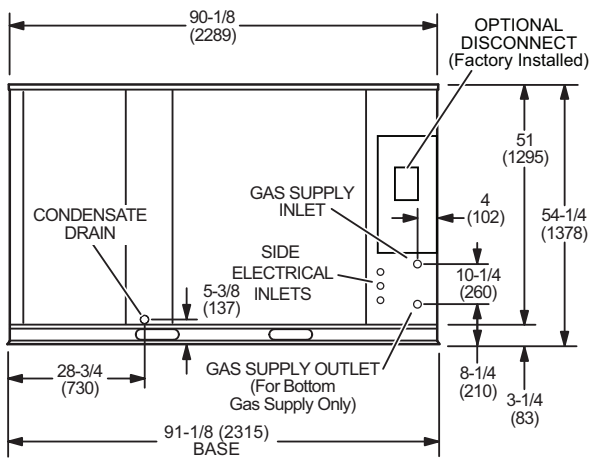
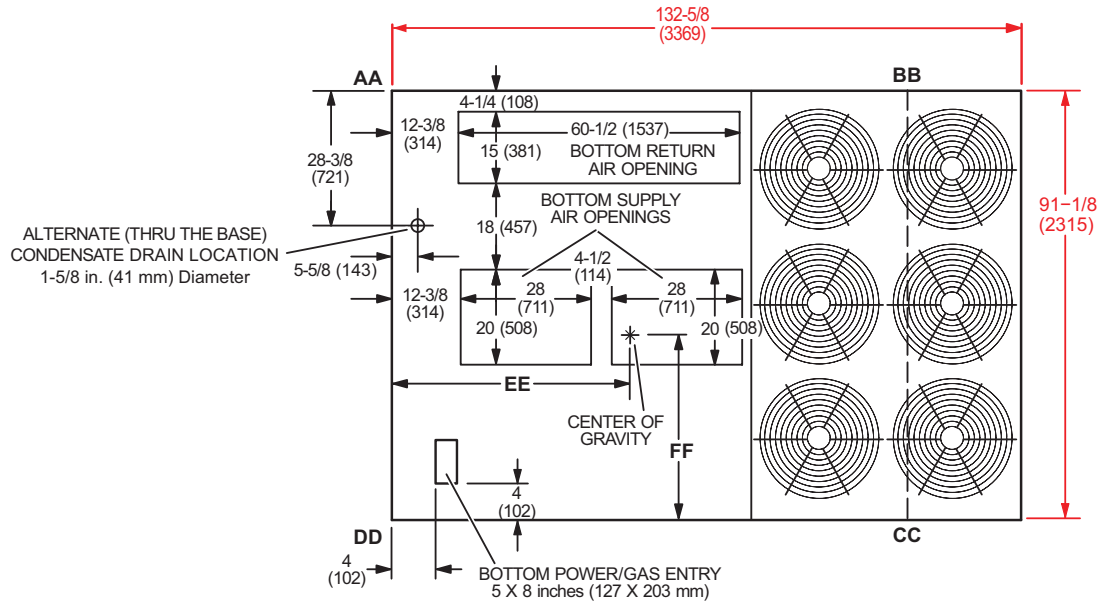


**END VIEW**

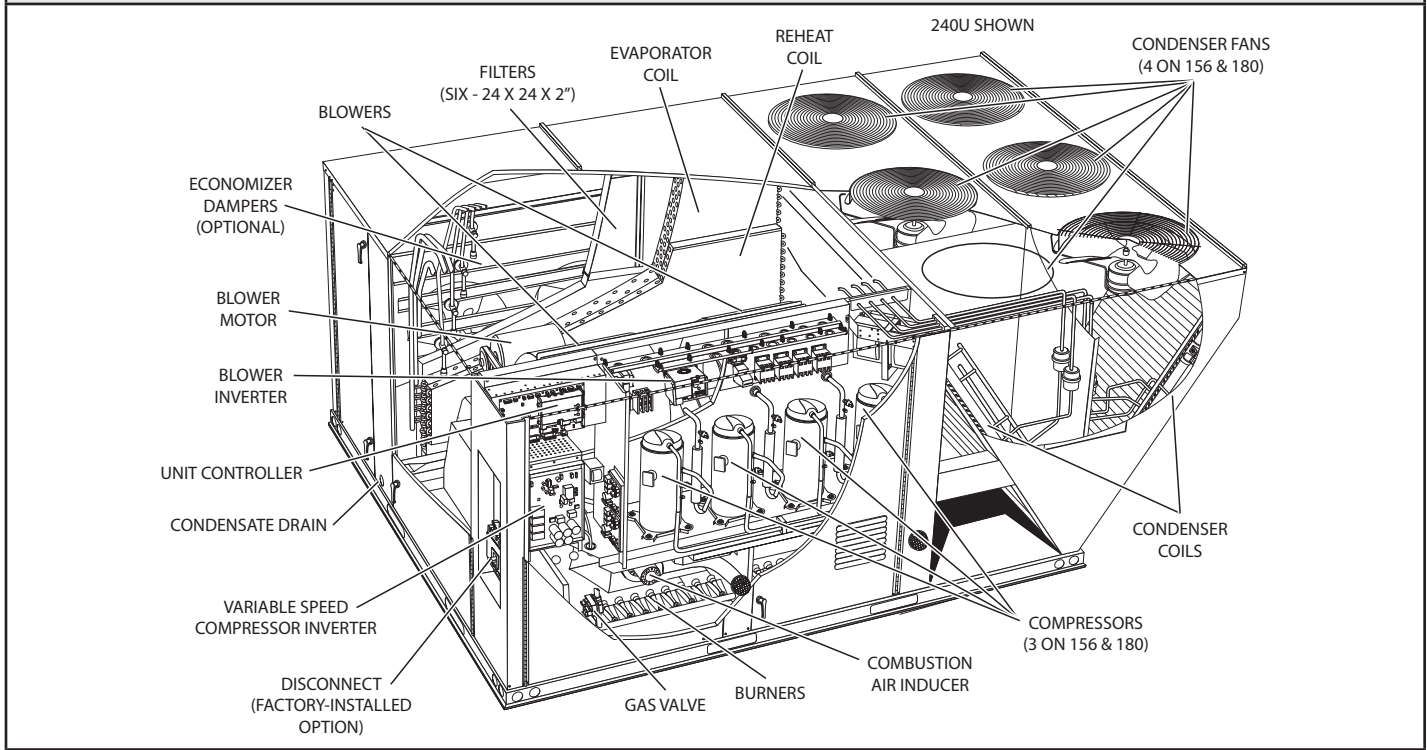


**SIDE VIEW**

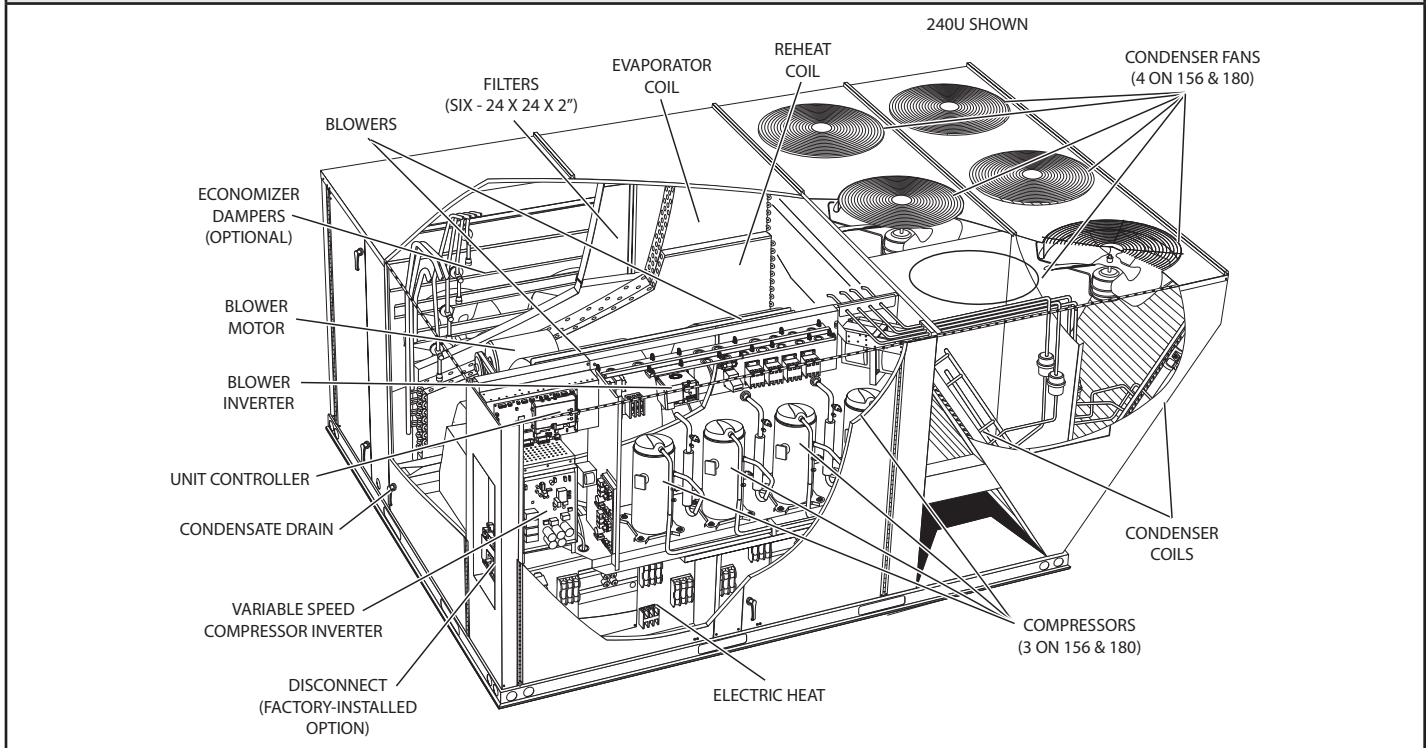
**LGM/LCM210U, 240U & 300U DIMENSIONS in. (mm) - Gas heat section shown**



## LGM156U, 180U, 210U, 240U, 300U PARTS ARRANGEMENT



## LCM156U, 180U, 210U, 240U, 300U PARTS ARRANGEMENT





## Shipping and Packing List

Package 1 of 1 contains:

- 1 - Assembled unit

**Check unit for shipping damage. Receiving party should contact last carrier immediately if shipping damage is found.**

## General

These instructions are intended as a general guide and do not supersede local codes in any way. Authorities having jurisdiction should be consulted before installation.

The LGM156U gas/electric packaged rooftop unit is available in 260,000 & 360,000 Btuh heating input. The LGM180U, 210U, 240U, & 300U gas/electric packaged rooftop units are available in 260,000, 360,000, or 480,000 Btuh heating inputs.

The LCM cooling packaged rooftop unit is the same basic design as the LGM unit except for the heating section. Optional electric heat is factory- or field-installed in LCM units.

LGM and LCM units have identical refrigerant circuits with respective 13, 15, 17-1/2, 20 and 25 ton cooling capacities. 156U and 180U units contain three compressors; one is variable speed and the other two are fixed speed compressors. 210U, 240U and 300U units contain four compressors; one is variable speed and the other three are fixed speed compressors.

Units come standard with a factory-installed all aluminum condenser coil.

Units are available with an optional hot gas reheat coil which provides a dehumidifying mode of operation. Refer to Reheat Operation section.

Units are available with variable air volume or single-zone variable air volume. Refer to the 9th character of the model number to determine type of blower:

V - Variable Air Volume

M - Single-Zone Variable Air Volume

Units use R454B, an ozone-friendly HFC refrigerant. Refer to the Cooling Start-Up section for precautions when installing unit.

## ⚠ WARNING



Electric shock hazard and danger of explosion. Can cause injury, death or product or property damage. Turn off gas and electrical power to unit before performing any maintenance or servicing operations on the unit. Follow lighting instructions attached to unit when putting unit back into operation and after service or maintenance.

## Requirements

See FIGURE 1 for unit clearances.

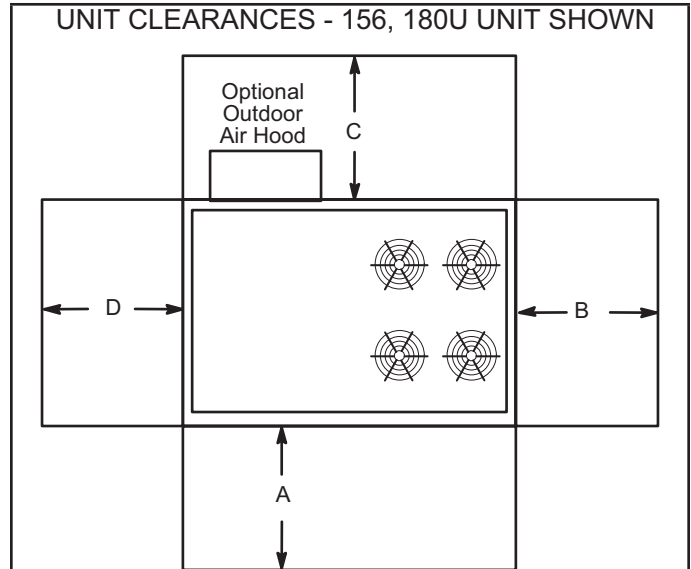


FIGURE 1

<sup>1</sup> Unit Clearance	A in.(mm)	B in.(mm)	C in.(mm)	D in.(mm)	Top Clearance
Service Clearance	60 (1524)	36 (914)	36 (914)	66 (1676)	Unobstructed
Clearance to Combustibles	36 (914)	1 (25)	1 (25)	1 (25)	Unobstructed
Minimum Operation Clearance	36 (914)	36 (914)	36 (914)	41 (1041)	Unobstructed

**NOTE** - Entire perimeter of unit base requires support when elevated above mounting surface.

- <sup>1</sup> Service Clearance - Required for removal of serviceable parts.  
 Clearance to Combustibles - Required clearance to combustible material (gas units). On LCM units, see clearance to combustible materials outlined on heater rating plate.  
 Minimum Operation Clearance - Required clearance for proper unit operation.

## Minimum R454B Space and CFM Requirements

Minimum Airflow <sup>1</sup>		
Unit	Q <sub>min</sub> (CFM)	Q <sub>min</sub> (m <sup>3</sup> /h)
LGM/LCM156	164	278
LGM/LCM180	165	281
LGM/LCM210	155	264
LGM/LCM240	160	272
LGM/LCM300	178	303

<sup>1</sup> **NOTE** - The minimum airflow is the lowest CFM allowed during venting operation (leak mitigation).

Minimum Room Area of Conditioned Space <sup>2</sup>		
Unit	TA <sub>min</sub> (ft <sup>2</sup> )	TA <sub>min</sub> (m <sup>2</sup> )
LGM/LCM156	91	8.4
LGM/LCM180	92	8.5
LGM/LCM210	87	8.0
LGM/LCM240	89	8.2
LGM/LCM300	99	9.2

<sup>2</sup> **NOTE** - The minimum room area of conditioned space is the smallest area the unit can service.

Refrigerant Charge R-454B		
Unit	M <sub>c</sub> (lbs)	M <sub>c</sub> (kg)
LCM/LGM156 Stg 1	6.19	2.81
LCM/LGM156 Stg 2	5.31	2.41
LCM/LGM156 Stg 3	5.69	2.58
LCM/LGM180 Stg 1	6.25	2.83
LCM/LGM180 Stg 2	6.13	2.78
LCM/LGM180 Stg 3	5.50	2.49
LCM/LGM210 Stg 1	5.88	2.66
LCM/LGM210 Stg 2	5.75	2.61
LCM/LGM210 Stg 3	5.00	2.27
LCM/LGM210 Stg 4	5.25	2.38
LCM/LGM240 Stg 1	6.06	2.75
LCM/LGM240 Stg 2	5.68	2.58
LCM/LGM240 Stg 3	5.12	2.32
LCM/LGM240 Stg 4	5.50	2.49
LCM/LGM300 Stg 1	6.75	3.06
LCM/LGM300 Stg 2	6.75	3.06
LCM/LGM300 Stg 3	6.19	2.81
LCM/LGM300 Stg 4	5.94	2.69

Altitude Adjustment Factor <sup>3</sup>									
Halt	0	200	400	600	800	1000	1200	1400	1600
AF	1	1	1	1	1.02	1.05	1.04	1.1	1.12
Halt	1600	1800	2000	2200	2400	2600	2800	3000	3200
AF	1.12	1.15	1.18	1.21	1.25	1.28	1.32	1.36	1.4

<sup>3</sup> **NOTE** - Use the Altitude Adjustment Factor to adjust the values in the tables above to different altitudes. Find the relevant altitude above sea level in the two "Halt" rows and then multiply the value needed from the tables above by the altitude factor number. Example: For the minimum airflow in CFM for an LCM/LGM156 at 1000 ft. above sea level, multiply 164 by 1.05 to get 172.2 CFM as the new Q<sub>min</sub>.



## NOTICE

### Roof Damage!

This system contains both refrigerant and oil. Some rubber roofing material may absorb oil, causing the rubber to swell. Bubbles in the rubber roofing material can cause leaks. Protect the roof surface to avoid exposure to refrigerant and oil during service and installation. Failure to follow this notice could result in damage to roof surface.

Use of this unit as a construction heater or air conditioner is not recommended during any phase of construction. Very low return air temperatures, harmful vapors and operation of the unit with clogged or misplaced filters will damage the unit.

If this unit has been used for heating or cooling of buildings or structures under construction, the following conditions must be met or the warranty will be void:

- The vent hood must be installed per these installation instructions.
- A room thermostat must control the unit. The use of fixed jumpers that will provide continuous heating or cooling is not allowed.
- A pre-filter must be installed at the entry to the return air duct.
- The return air duct must be provided and sealed to the unit.
- Return air temperature range between 55°F (13°C) and 80°F (27°C) must be maintained.
- Air filters must be replaced and pre-filters must be removed upon construction completion.
- The input rate and temperature rise must be set per the unit rating plate.
- The heat exchanger, components, duct system, air filters and evaporator coil must be thoroughly cleaned following final construction clean-up.
- The unit operating conditions (including airflow, cooling operation, ignition, input rate, temperature rise and venting) must be verified according to these installation instructions.

This appliance is not intended for use by persons (including children) with reduced physical, sensory, or mental capabilities, or lack of experience and knowledge, unless they have been given supervision or instruction concerning use of the appliance by a person responsible for their safety.

## Unit Support

In downflow discharge installations, install the unit on a non-combustible surface only. Unit may be installed on combustible surfaces when used in horizontal discharge applications or in downflow discharge applications when installed on an LARMF18/36 roof mounting frame.

**NOTE** - Securely fasten roof frame to roof per local codes.

## CAUTION

To reduce the likelihood of supply / return air by pass and promote a proper seal with the RTU, duct work / duct drops / diffuser assemblies must be supported independently to the building structure.

### A-Downflow Discharge Application

#### Roof Mounting with LARMF18/36

- 1 - The LARMF roof mounting frame must be installed, flashed and sealed in accordance with the instructions provided with the frame.
- 2 - The LARMF roof mounting frame should be square and level to 1/16" per linear foot (5mm per linear meter) in any direction.
- 3 - Duct must be attached to the roof mounting frame and not to the unit; supply and return plenums must be installed before setting the unit.

#### Installer's Roof Mounting Frame

Many types of roof frames can be used to install the unit depending upon different roof structures. Items to keep in mind when using the building frame or supports are:

- 1 - The base is fully enclosed and insulated, so an enclosed frame is not required.
- 2 - The frames or supports must be constructed with non-combustible materials and should be square and level to 1/16" per linear foot (5mm per linear meter) in any direction.
- 3 - Frame or supports must be high enough to prevent any form of moisture from entering unit. Recommended minimum frame height is 14" (356mm).
- 4 - Duct must be attached to the roof mounting frame and not to the unit. Supply and return plenums must be installed before setting the unit.

- 5 - Units require support along all four sides of unit base. Supports must be constructed of steel or suitably treated wood materials.

**NOTE** - When installing a unit on a combustible surface for downflow discharge applications, an LARMF18/36 roof mounting frame is required.

**B-Horizontal Discharge Applications**

- 1 - Units installed in horizontal airflow applications must use an LARMFH18/24 horizontal roof mounting frame. The supply air duct connects to the horizontal supply air opening on the LARMFH18/24. The return air duct connects to the unit horizontal return air opening. Refer to unit dimensions.
- 2 - Specified installation clearances must be maintained when installing units. Refer to FIGURE 1.
- 3 - Top of support slab should be approximately 4” (102mm) above the finished grade and located so no run-off water from higher ground can collect around the unit.
- 4 - Units require support along all four sides of unit base. Supports must be constructed of steel or suitably treated wood materials.

**Duct Connection**

All exterior ducts, joints and openings in roof or building walls must be insulated and weather-proofed with flashing and sealing compounds in accordance with applicable codes. Any duct passing through an unconditioned space must be insulated.

**⚠ CAUTION**  
 In downflow applications, do not drill or punch holes in base of unit. Leaking in roof may occur if unit base is punctured.

**Rigging Unit for Lifting**

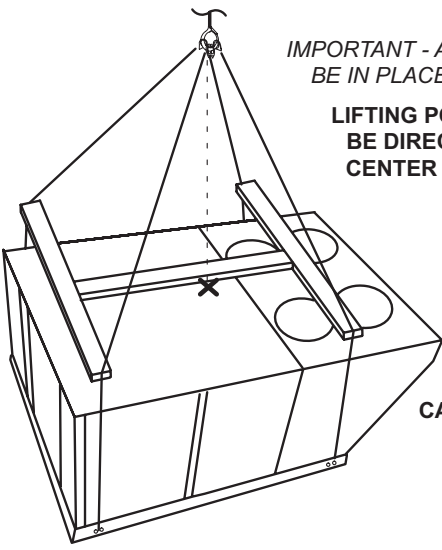
Rig unit for lifting by attaching four cables to holes in unit base rail. See FIGURE 2.

- 1 - Detach wooden base protection before rigging.
- 2 - Connect rigging to the unit base using both holes in each corner.
- 3 - All panels must be in place for rigging.
- 4 - Place field-provided H-style pick in place just above top edge of unit. Frame must be of adequate strength and length. (H-style pick prevents damage to unit.)

**RIGGING**

Unit	*Weight	
	Lbs.	Kg.
LCM/LGM156, 180	2682	1216
LCM/LGM210, 240, 300	3188	1446

\*Maximum weight with all available factory-installed accessories.



**IMPORTANT - ALL PANELS MUST BE IN PLACE FOR RIGGING**

**LIFTING POINT SHOULD BE DIRECTLY ABOVE CENTER OF GRAVITY**

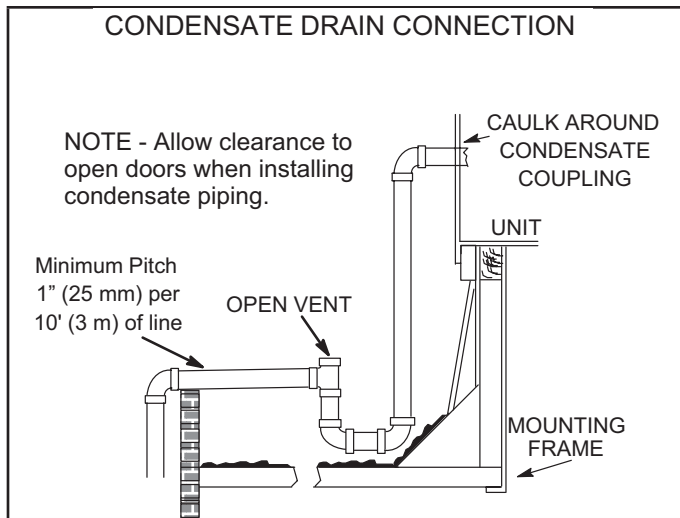
**CAUTION - Do not walk on unit.**

**FIGURE 2**

**Condensate Drains**

Remove cap and make drain connection to the 1” N.P.T. drain coupling provided on unit. A trap must be installed between drain connection and an open vent for proper condensate removal. See FIGURE 3. It is sometimes acceptable to drain condensate onto the roof or grade; however, a tee should be fitted to the trap to direct condensate downward. The condensate line must be vented. Check local codes concerning condensate disposal. Refer to page 4 through page 6 for condensate drain location.

**NOTE** - The drain pan is made with a glass reinforced engineered plastic capable of withstanding typical joint torque but can be damaged with excessive force. Tighten pipe nipple hand tight and turn an additional quarter turn.



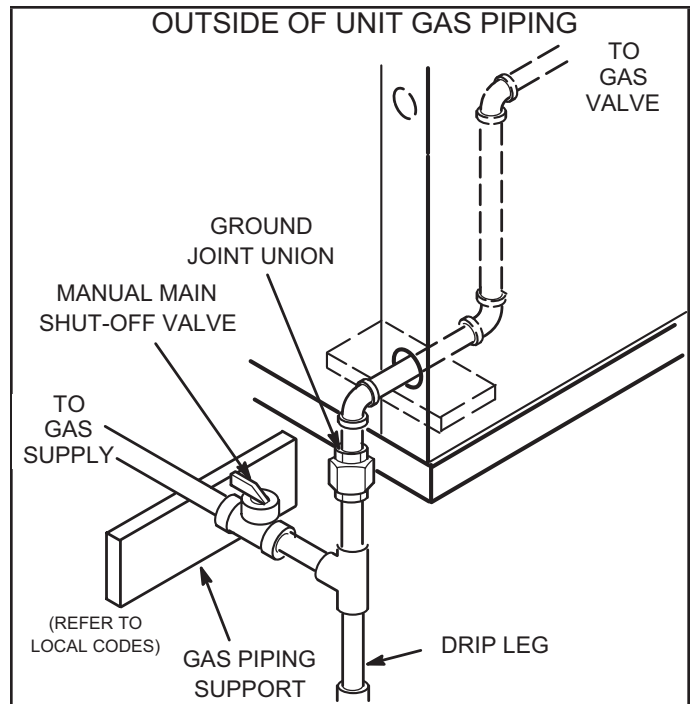
**FIGURE 3**

**Connect Gas Piping**

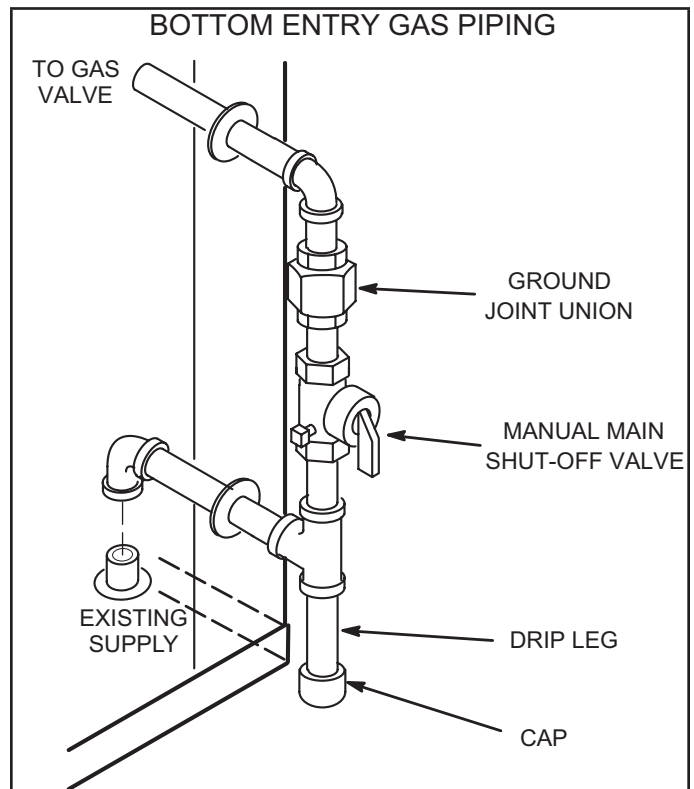
Before connecting piping, check with gas company or authorities having jurisdiction for local code requirements. When installing gas supply piping, length of run from gas meter must be considered in determining pipe size for 0.5" w.c. (.12kPa) maximum pressure drop. Do not use supply pipe smaller than unit gas connection. For natural gas units, operating pressure at the unit gas connection must be a minimum of 4.7" w.c. (1.17kPa) and a maximum of 10.5" (2.60kPa) w.c. For LP/propane gas units, operating pressure at the unit gas connection must be a minimum of 11" w.c. (2.74kPa) and a maximum of 13.5" w.c. (3.36kPa).

When making piping connections a drip leg should be installed on vertical pipe runs to serve as a trap for sediment or condensate. A 1/8" N.P.T. plugged tap is located on gas valve for test gauge connection. Refer to Heating Start-Up section for tap location. Install a ground joint union between the gas control manifold and the main manual shut-off valve. See FIGURE 4 for gas supply piping entering outside the unit. See FIGURE 5 for gas supply entering through bottom of unit.

Compounds used on threaded joints of gas piping shall be resistant to the action of liquefied petroleum gases.



**FIGURE 4**



**FIGURE 5**

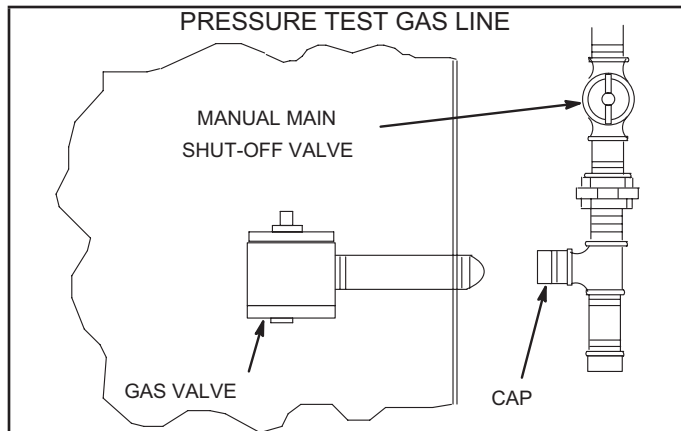
**Pressure Test Gas Piping**

When pressure testing gas lines, the gas valve must be disconnected and isolated. Gas valves can be damaged if subjected to more than 0.5 psig (3.48kPa). See FIGURE 6.

**NOTE** - Codes may require that manual main shut-off valve and union (furnished by installer) be installed in gas line external to unit. Union must be of the ground joint type.

After all connections have been made, check all piping connections for gas leaks. Also check existing unit gas connections up to the gas valve; loosening may occur during installation. Use a leak detection solution or other preferred means. Do not use matches candles or other sources of ignition to check for gas leaks.

**NOTE** - In case emergency shut down is required, turn off the main manual shut-off valve and disconnect main power to unit. These devices should be properly labeled by the installer.



**FIGURE 6**

## CAUTION

Some soaps used for leak detection are corrosive to certain metals. Carefully rinse piping thoroughly after leak test has been completed. Do not use matches, candles, flame or other sources of ignition to check for gas leaks.

## WARNING



Danger of explosion. Can cause injury or product or property damage. Do not use matches, candles, flame or other sources of ignition to check for leaks.

## High Altitude Derate

Locate the high altitude conversion sticker in the unit literature bag. Fill out the conversion sticker and affix next to the unit nameplate. High altitude kits are available for field-installation.

Refer to TABLE 1 for high altitude adjustments.

**TABLE 1  
HIGH ALTITUDE DERATE**

Altitude Ft.*	Gas Manifold Pressure
2000-4500	See Unit Nameplate
4500 & Above	Derate 2% / 1000 Ft. Above Sea Level
4500 & Above	Derate 4% / 1000 Ft. Above Sea Level

\*Units installed at 0-2000 feet do not need to be modified.

**NOTE** - This is the only permissible derate for these units

## Electrical Connections - Power Supply

### A-Wiring

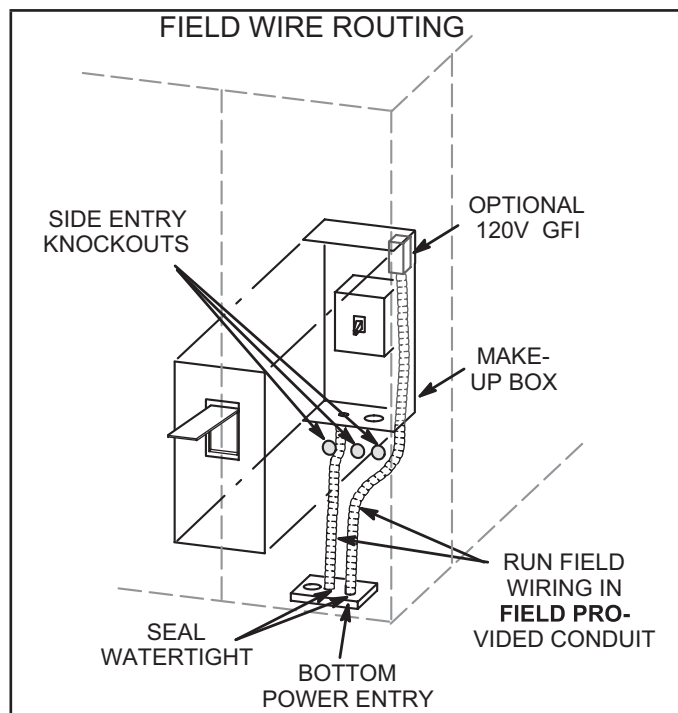
Route field wiring in conduit between bottom power entry and disconnect. See FIGURE 7. This does not supersede local codes or authorities having jurisdiction.

Do not apply power or close disconnect switch until installation is complete. Refer to start-up directions. Refer closely to unit wiring diagram.

Refer to unit nameplate for minimum circuit ampacity and maximum fuse size.

- Units are factory-wired for 240/460/575 volt supply. For 208V supply, remove the insulated terminal cover from the 208V terminal on the control transformer. Move the wire from the transformer 240V terminal to the 208V terminal. Place the insulated terminal cover on the unused 240V terminal.
- Route power through the bottom power entry area and connect to line side of unit disconnect, circuit breaker or terminal block. See unit wiring diagram.
- Units With Optional 120v GFCI Outlet

Route and connect separate 120v wiring to GFCI outlets which do not have factory-installed wiring. Route field wiring in conduit between bottom power entry and GFCI. See FIGURE 7.



**FIGURE 7**

## B-Unbalanced Three-Phase Voltage

Units equipped with an inverter (VFD) are designed to operate on balanced, three-phase power. Operating units on unbalanced three-phase power will reduce the reliability of all electrical components in the unit. Unbalanced power is a result of the power delivery system supplied by the local utility company.

Factory-installed inverters are sized to drive blower motors with an equivalent current rating using balanced three-phase power. When unbalanced three-phase power is supplied; the installer must replace the existing factory-installed inverter with an inverter that has a higher current rating to allow for the imbalance. Use TABLE 2 to determine the appropriate replacement inverter.

**TABLE 2  
INVERTER UP-SIZING**

Factory-Installed Inverter HP	Replacement Inverter HP
2	5
3	7-1/2
5	10
7.5	15
10	20

## Electrical Connections - Control Wiring

Connect either a thermostat, room/zone sensor, or direct digital controller; one of the three are required for unit function. Refer to the literature provided with each device and the following information.

**NOTE** - Optional wireless sensors are available for use with this unit.

### A-Thermostat Location

Room thermostat mounts vertically on a standard 2" X 4" handy box or on any non-conductive flat surface.

Locate thermostat approximately 5 feet (1524mm) above the floor in an area with good air circulation at average temperature. Avoid locating the room thermostat where it might be affected by:

- drafts or dead spots behind doors and in corners
- hot or cold air from ducts
- radiant heat from sun or appliances
- concealed pipes and chimneys

### B-Wire Routing

Route thermostat cable or wires from subbase through knockout provided in unit. Use 18 AWG wire for all applications using remotely installed electro-mechanical and electronic thermostats.

On hot gas reheat units, route wires from RH sensor or remote switch through knockout provided in unit. For sensor installations, use 22AWG stranded, two twisted pairs, individually shielded, 100% aluminum shield with drain wire and Teflon jacket.

**IMPORTANT** - Unless field thermostat wires are rated for maximum unit voltage, they must be routed away from line voltage wiring.

## C-Wire Connections

The Unit Controller will operate the unit from a thermostat or zone sensor based on the System Mode. The default System Mode is the thermostat mode. Refer to the Unit Controller Setup Guide to change the System Mode. Use the mobile service app menu and select:

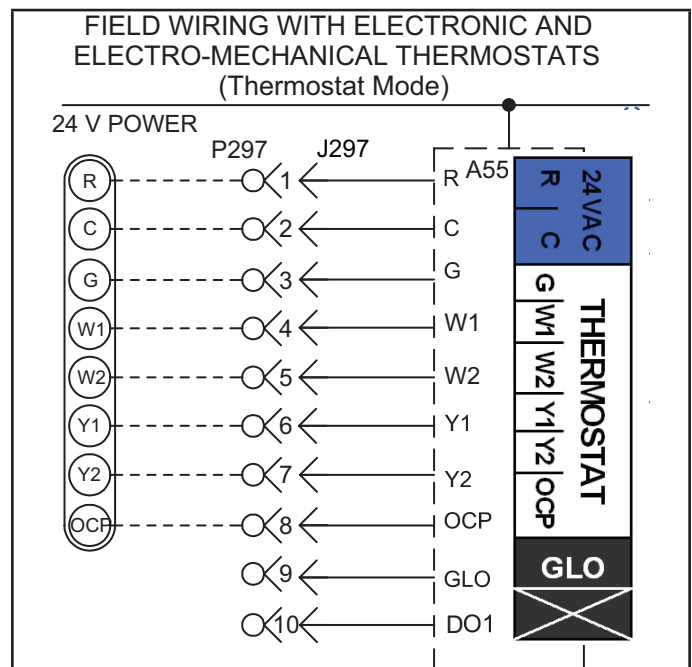
### SETTINGS > INSTALL.

**NOTE** - Unit Controller is capable of up to four stages of cooling in network control mode.

#### 1 - Default Thermostat Mode

The Unit Controller will operate two stages of heating and cooling based on thermostat demands. Install thermostat assembly in accordance with instructions provided with thermostat. See FIGURE 8 for field wiring and refer to wiring diagrams on unit.

**IMPORTANT** - Terminal connections at the wall plate or subbase must be made securely. Loose control wire connections may result in intermittent operation.



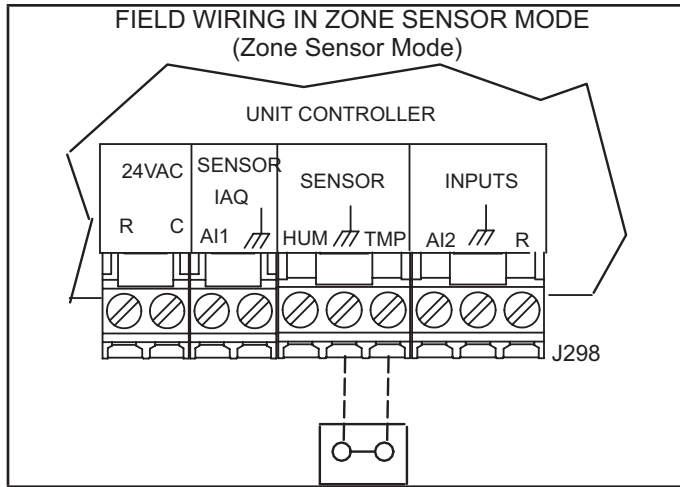
**FIGURE 8**

#### 2 - Zone Sensor Mode

The Unit Controller will operate heating and cooling based on the Unit Controller internal setpoints and the temperature from the A2 zone sensor. An optional Network Control Panel (NCP) can also be used to provide setpoints. A thermostat or return air sensor can be used as a back-up mode. Make zone sensor wiring connections as shown in FIGURE 9.



**NOTE** - Install sensor and make communication wiring connections as shown in literature provided with sensor.



**FIGURE 9**

**D-Hot Gas Reheat Units Only**

- 1 - Install humidity sensor in accordance with instructions provided with sensor. A DDC input may be used to initiate dehumidification instead of a sensor.
- 2 - Make wiring connections as shown in FIGURE 8 for Thermostat Mode and figure 10 for Zone Sensor Mode. In addition, connect either a humidity sensor or a dehumidification input. See FIGURE 10 or FIGURE 11 for humidity sensor wiring and FIGURE 12 for dehumidification input wiring.

**Humidity Sensor Cable Applications**

**Wire runs of 50 feet (mm) or less**

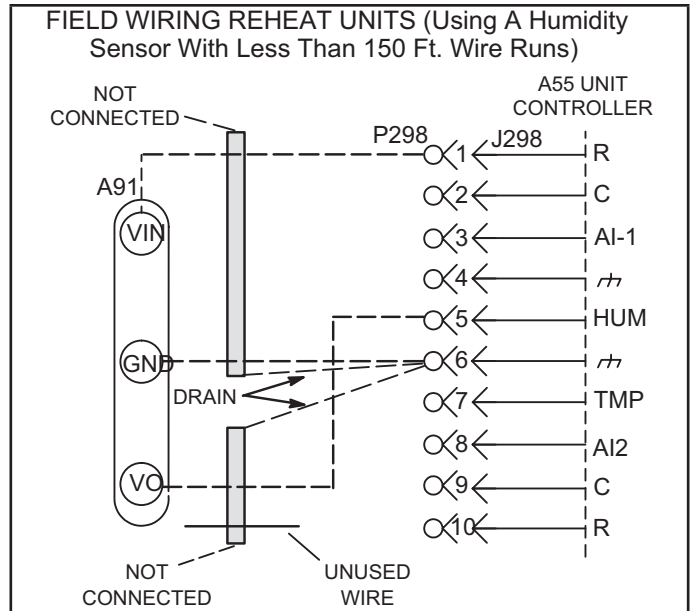
Use two separate shielded cables containing 20AWG minimum, twisted pair conductors with overall shield. Belden type 8762 or 88760 (plenum) or equivalent. Connect both cable shield drain wires to TB1-7 as shown in FIGURE 10.

**Wire runs of 150 feet (mm) or less**

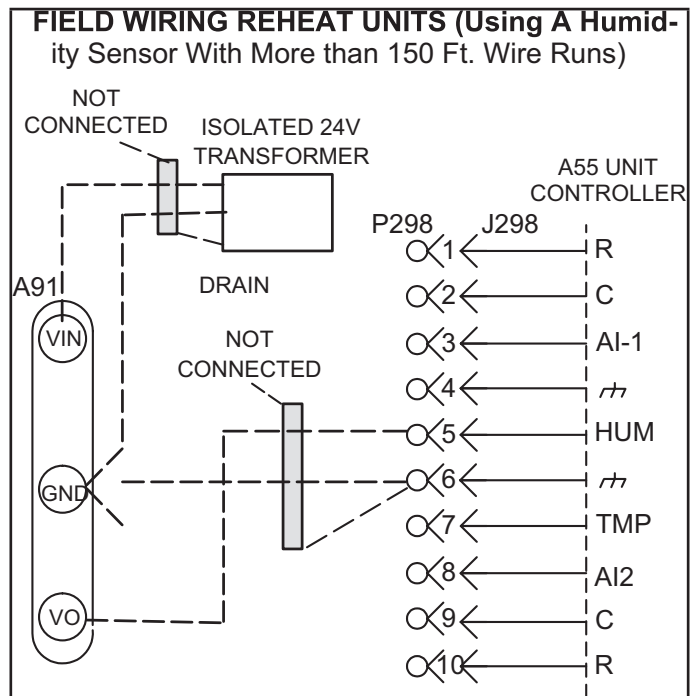
Use two separate shielded cables containing 18AWG minimum, twisted pair conductors with overall shield. Belden type 8760 or 88760 (plenum) or equivalent. Connect both cable shield drain wires to TB1-7 as shown in FIGURE 10.

**Wire runs over 150 feet (mm)**

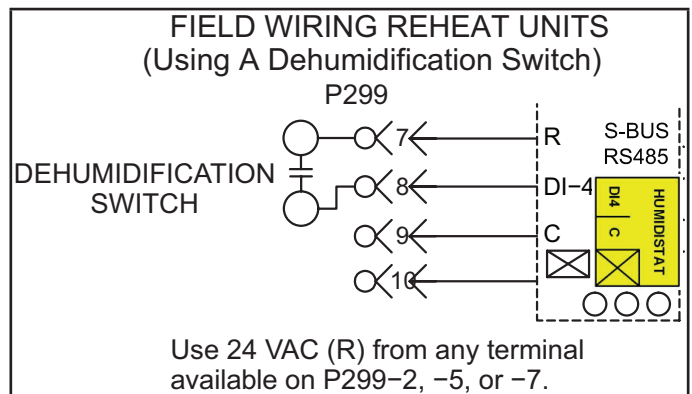
Use a local, isolated 24VAC transformer such as Lennox cat #18M13 (20VA minimum) to supply power to RH sensor as shown in FIGURE 11. Use two shielded cables containing 20AWG minimum, twisted pair conductors with overall shield. Belden type 8762 or 88760 (plenum) or equivalent.



**FIGURE 10**



**FIGURE 11**



Use 24 VAC (R) from any terminal available on P299-2, -5, or -7.

**FIGURE 12**



## Mobile Service App

Setup and configure each rooftop unit using the mobile service app (Android or iOS devices supported).

### A-Mobile Device Requirements

- Bluetooth connection.
- Android hardware requires 2GB RAM and a 2Ghz core processor. Tablets are supported.
- The app is available for both iOS 11.0 or higher (App Store) and Android 9.0 or higher (Google Play).

### B-Download the App

Use your mobile device to scan the QR code from the cover page and download the mobile service app to your mobile device.

### C-Pair the App to the Unit Controller

- 1 - Apply power to the unit and wait until the Unit Controller has booted-up (approximately two minutes).
- 2 - Press and hold the pair button for five seconds. See FIGURE 14.
- 3 - The unit (or list of units) will appear; select the appropriate unit. When the app code matches the four-character code on the Unit Controller display, the unit is paired (within 10 seconds). Note the following:
  - The app will pair with the unit controller when the mobile device is within 50 feet of the unit.
  - The app will list the units by signal strength; the RTU name will be displayed.
  - Once paired, the RTU name, model number, serial number and firmware version will be displayed.

Please refer to the manufacturer's website for additional technical information and self-help support.

## D-App Menus

See FIGURE 13 for the menu overview. Follow the app prompts in the Install, Network Integration, and Test and Balance menus. Verify the app is setup properly for the unit application (including the date and time). Refer to FIGURE 15, FIGURE 16, and FIGURE 17.

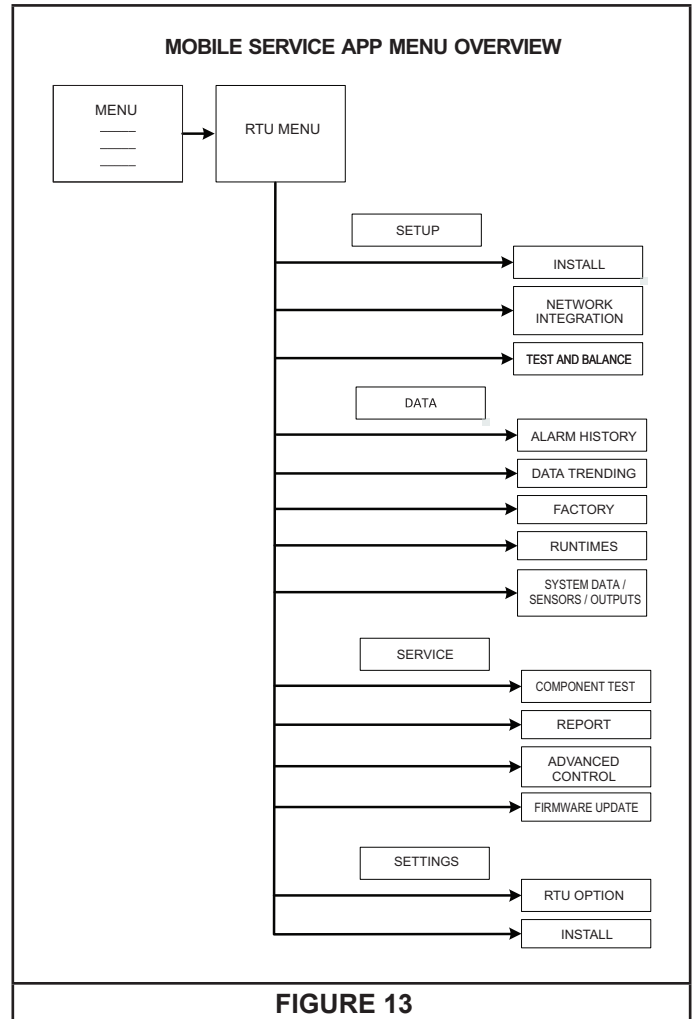


FIGURE 13

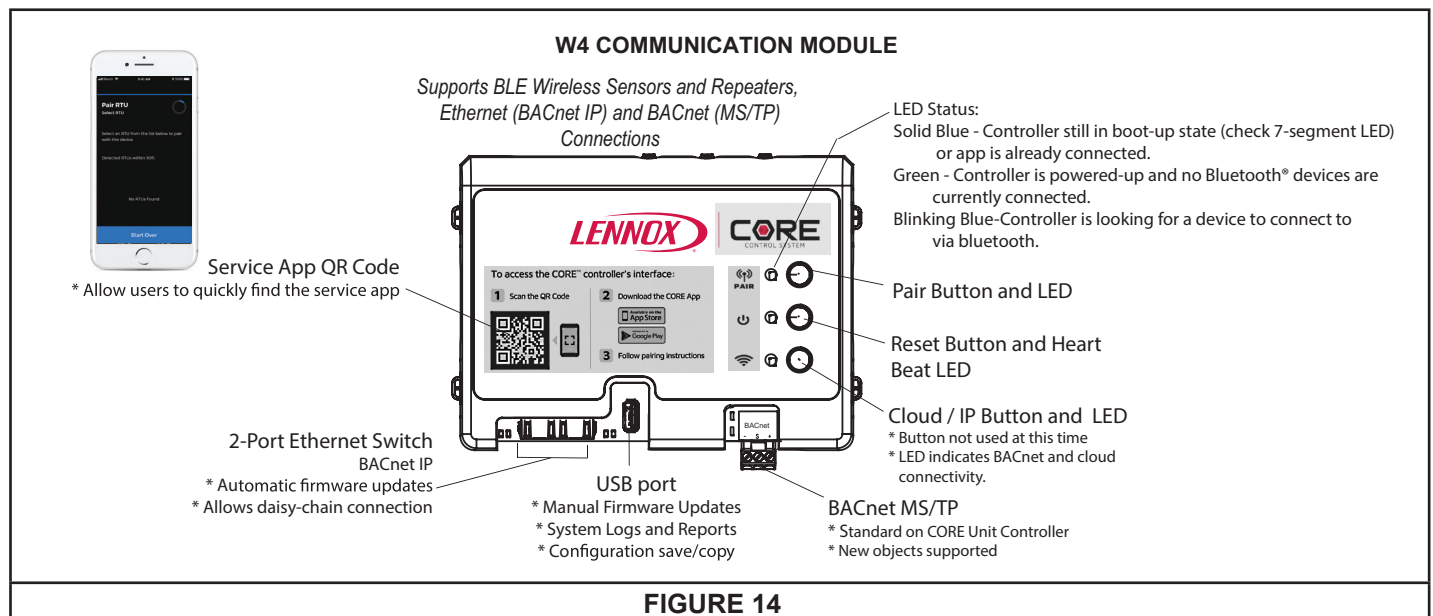
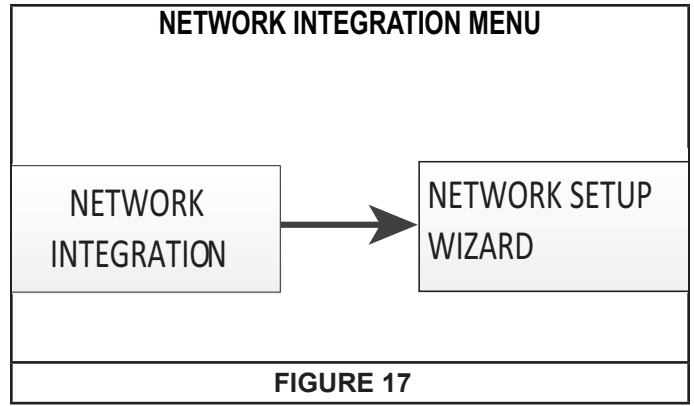
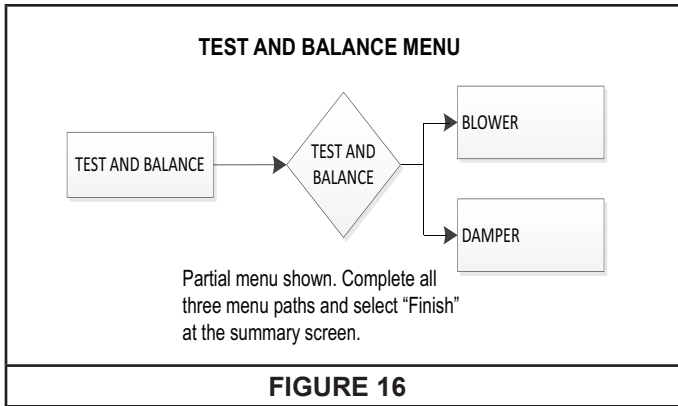
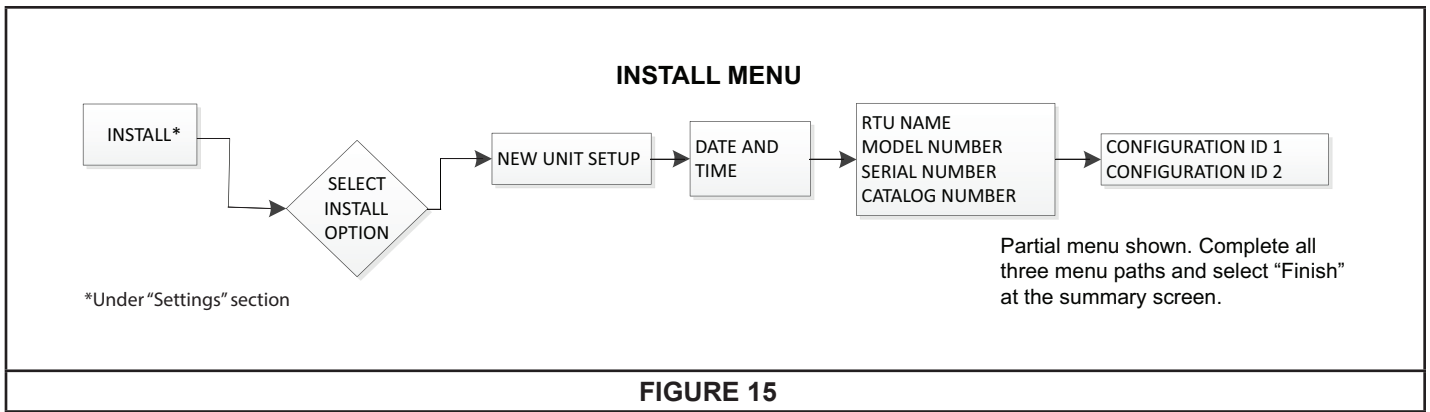
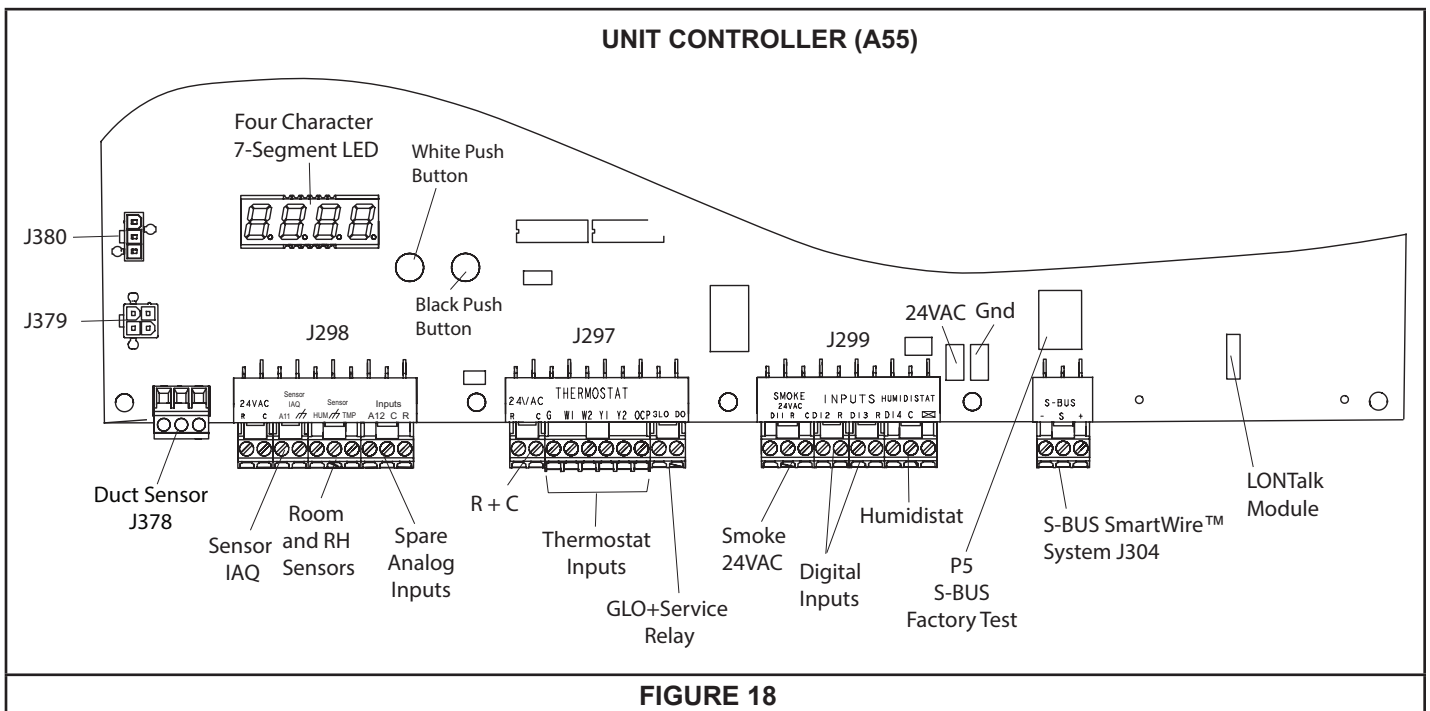


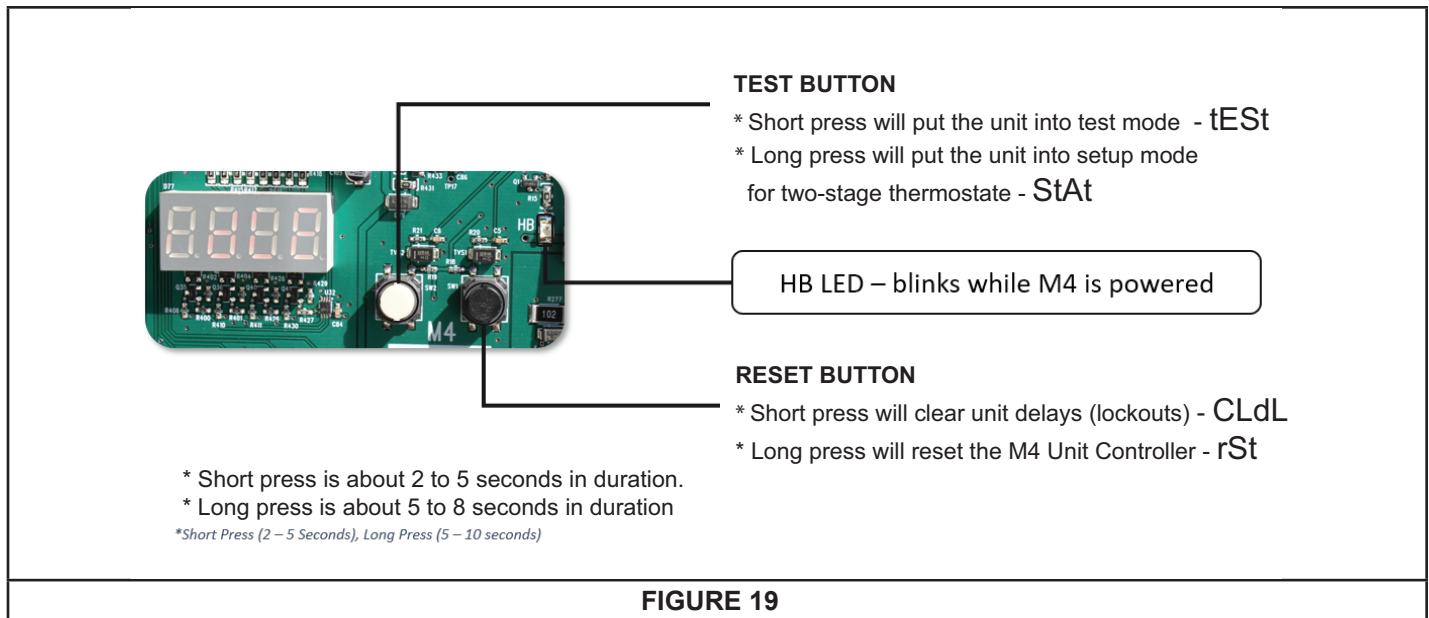
FIGURE 14



## E-Unit Controller Components

See FIGURE 18 for Unit Controller components. See FIGURE 19 and TABLE 3 for pushbutton and LED functions.





**FIGURE 19**

<b>UNIT CONTROLLER PUSHBUTTON CODES</b>		
<b>Code</b>	<b>Cause</b>	<b>Action</b>
CLdL	Black Button: Short Press	Clear Delays
rSt	Black Button: Long Press	Reset
tEst	White Button: Short Press	TSTAT Test
StAt	White Button: Long Press (In Pre-Install state)	TSTAT Override
tEst	White Button: Long Press (NOT in Pre-Install State)	TSTAT Test

Short Press : 2 to 5 seconds.  
 Long Press : 5 to 8 seconds.

**Blower Operation and Adjustments**

Supply Air Staged Units - The blower rotation will always be correct on units equipped with an inverter. Checking blower rotation is not a valid method of determining voltage phasing for incoming power.

Supply Air Staged Units and Units Equipped With Optional Voltage or Phase Detection - The Unit Controller checks the incoming power during start-up. If the voltage or phase is incorrect, the Unit Controller will display an alarm and the unit will not start.

**A-Blower Operation**

Refer to the Unit Controller Setup Guide to energize blower. Use this mobile service app menu:

**SERVICE > TEST > BLOWER**

Instructions provided with the thermostat may also be used to initiate blower only (G) demand. Unit will cycle on thermostat demand. The following steps apply to applications using a typical electro-mechanical thermostat.

- 1 - Blower operation is manually set at the thermostat subbase fan switch. With fan switch in ON position, blowers will operate continuously.
- 2 - With fan switch in AUTO position, the blowers will cycle with demand. Blowers and entire unit will be off when system switch is in OFF position.

**⚠ IMPORTANT**

**Three Phase Scroll Compressor Voltage Phasing**

Three phase scroll compressors must be phased sequentially to ensure correct compressor and blower\* rotation and operation. Compressor and blower are wired in phase at the factory. Power wires are color-coded as follows: line 1-red, line 2-yellow, line 3-blue.

- 1- Observe suction and discharge pressures and blower\* rotation on unit start-up.
- 2- Suction pressure must drop, discharge pressure must rise and blower\* rotation must match rotation marking. If pressure differential is not observed or blower\* rotation is not correct:
- 3- Disconnect all remote electrical power supplies.
- 4- Reverse any two field-installed wires connected to the line side of S48 disconnect or TB13 terminal strip. Do not reverse wires at blower contactor.
- 5- Make sure the connections are tight.

Discharge and suction pressures should operate at their normal start-up ranges.

\*Supply air inverter blower motors should rotate in the correct direction; verify scroll compressor rotation separately. Contact technical support if the blower is rotating incorrectly.

## ⚠ WARNING

- 1- Make sure that unit is installed in accordance with the installation instructions and applicable codes.
- 2- Inspect all electrical wiring, both field and factory-installed, for loose connections. Tighten as required.
- 3- Check to ensure that refrigerant lines do not rub against the cabinet or against other refrigerant lines.
- 4- Check voltage at disconnect switch. Voltage must be within range listed on nameplate. If not, consult power company and have voltage condition corrected before starting unit.
- 5- Make sure filters are new and in place before start-up.

### B-Blower Access

Disconnect jack/plug connector to blower motor. Also disconnect jack/plug connector heating limit switches on gas units.

Remove screws on either side of blower assembly sliding base. See FIGURE 21.

Pull base toward outside of unit.

### C-Determining Unit CFM

**IMPORTANT** - Multi-staged supply air units are factory-set to run the blower at full speed when there is a blower (G) demand without a heating or cooling demand. Refer to the field-provided, design specified CFM for all modes of operation. Use the following procedure to adjust motor pulley to deliver the highest CFM called for in the design spec. See Inverter Start-Up section to set blower CFM for all modes once the motor pulley is set

### Variable Air Volume Units - Refer to the Variable Air Volume Start-Up section.

The following measurements must be made with a dry indoor coil. Run blower (G demand) without a cooling demand. Measure the indoor blower shaft RPM. Air filters must be in place when measurements are taken.

With all access panels in place, measure static pressure external to unit (from supply to return). Blower performance data is based on static pressure readings taken in locations shown in FIGURE 20.

**NOTE** - Static pressure readings can vary if not taken where shown.

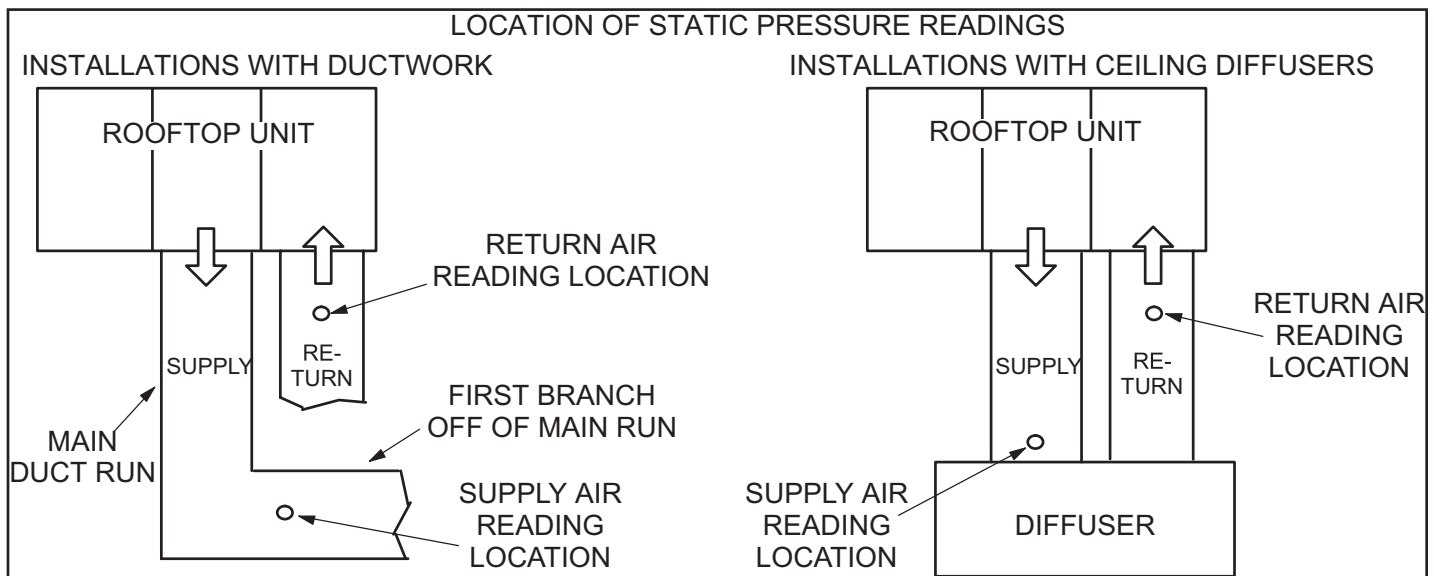
Referring to page 22, use static pressure and RPM readings to determine unit CFM. Use page 23 when installing units with any of the optional accessories listed.

The blower RPM can be adjusted at the motor pulley. Loosen Allen screw and turn adjustable pulley clockwise to increase CFM. Turn counterclockwise to decrease CFM. See FIGURE 21. Do not exceed minimum and maximum number of pulley turns as shown in TABLE 4.

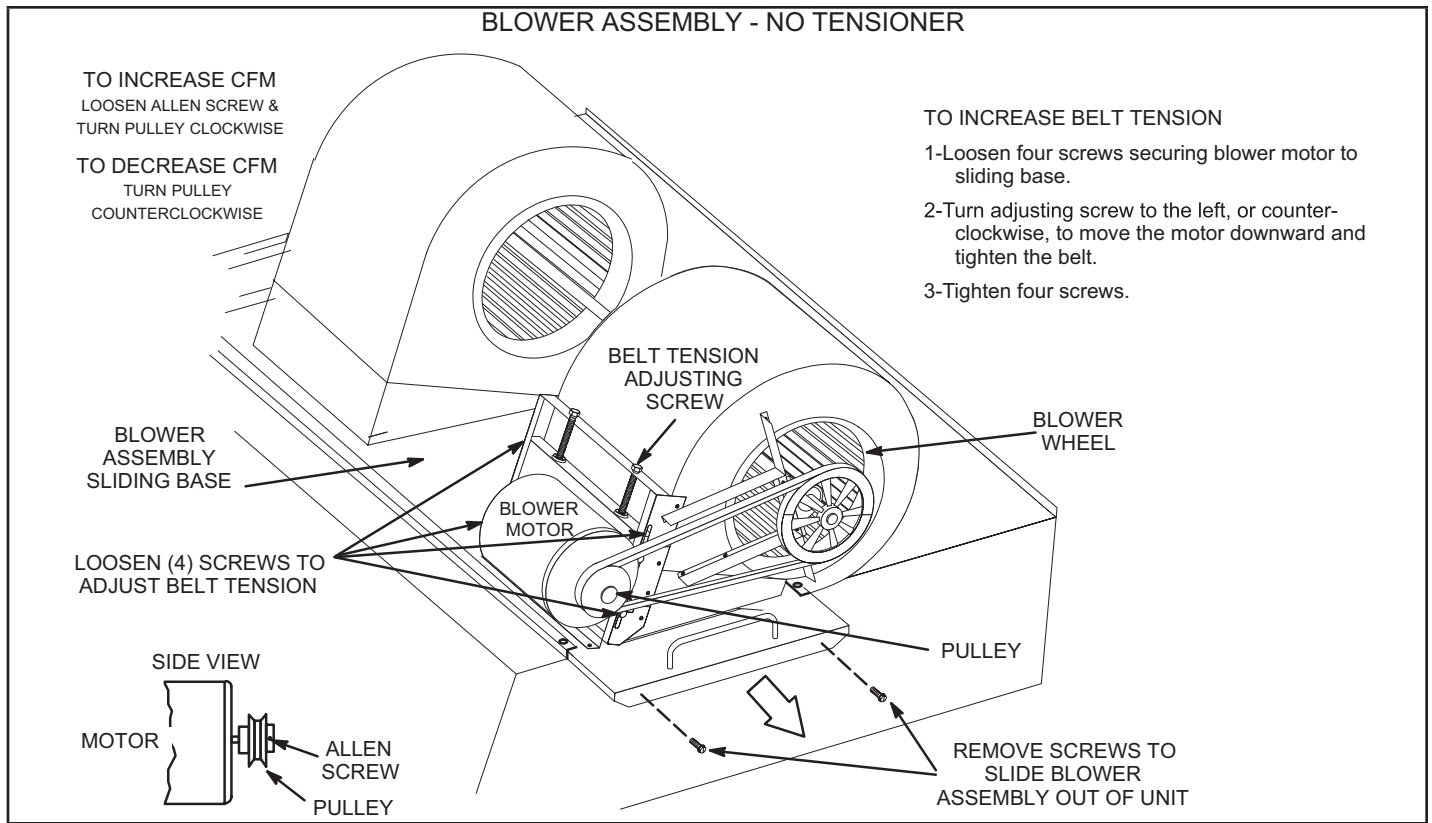
**TABLE 4**  
**MINIMUM AND MAXIMUM PULLEY ADJUSTMENT**

Belt	Minimum Turns Open	Maximum Turns Open
A Section	No minimum	5
B Section	1*	6

\*No minimum number of turns open when B belt is used on pulleys 6" O.D. or larger.



**FIGURE 20**



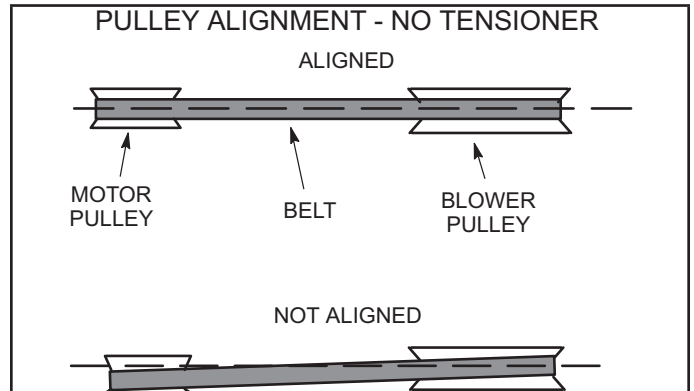
**FIGURE 21**

**D-Blower Belt Adjustment**

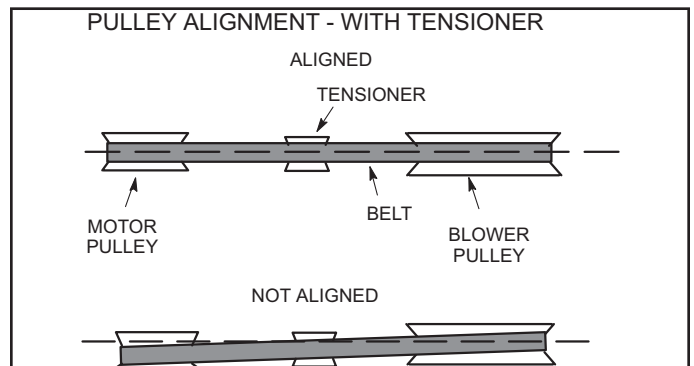
Maximum life and wear can be obtained from belts only if proper pulley alignment and belt tension are maintained. Tension new belts after a 24-48 hour period of operation. This will allow belt to stretch and seat into pulley grooves. Make sure blower and motor pulley are aligned. See FIGURE 22 for blowers not equipped with a tensioner and FIGURE 23 for units equipped with an optional belt tensioner.

**Blowers Without Belt Tensioner**

- 1 - Loosen four screws securing blower motor to sliding base. See FIGURE 21.
- 2 - To increase belt tension  
Turn belt tension adjusting screw to the left, or counterclockwise, to tighten the belt. This increases the distance between the blower motor and the blower housing.  
To loosen belt tension  
Turn the adjusting screw to the right, or clockwise to loosen belt tension.
- 3 - Tighten four screws securing blower motor to sliding base once adjustments have been made.



**FIGURE 22**



**FIGURE 23**

PULLEY ALIGNMENT - WITH TENSIONER

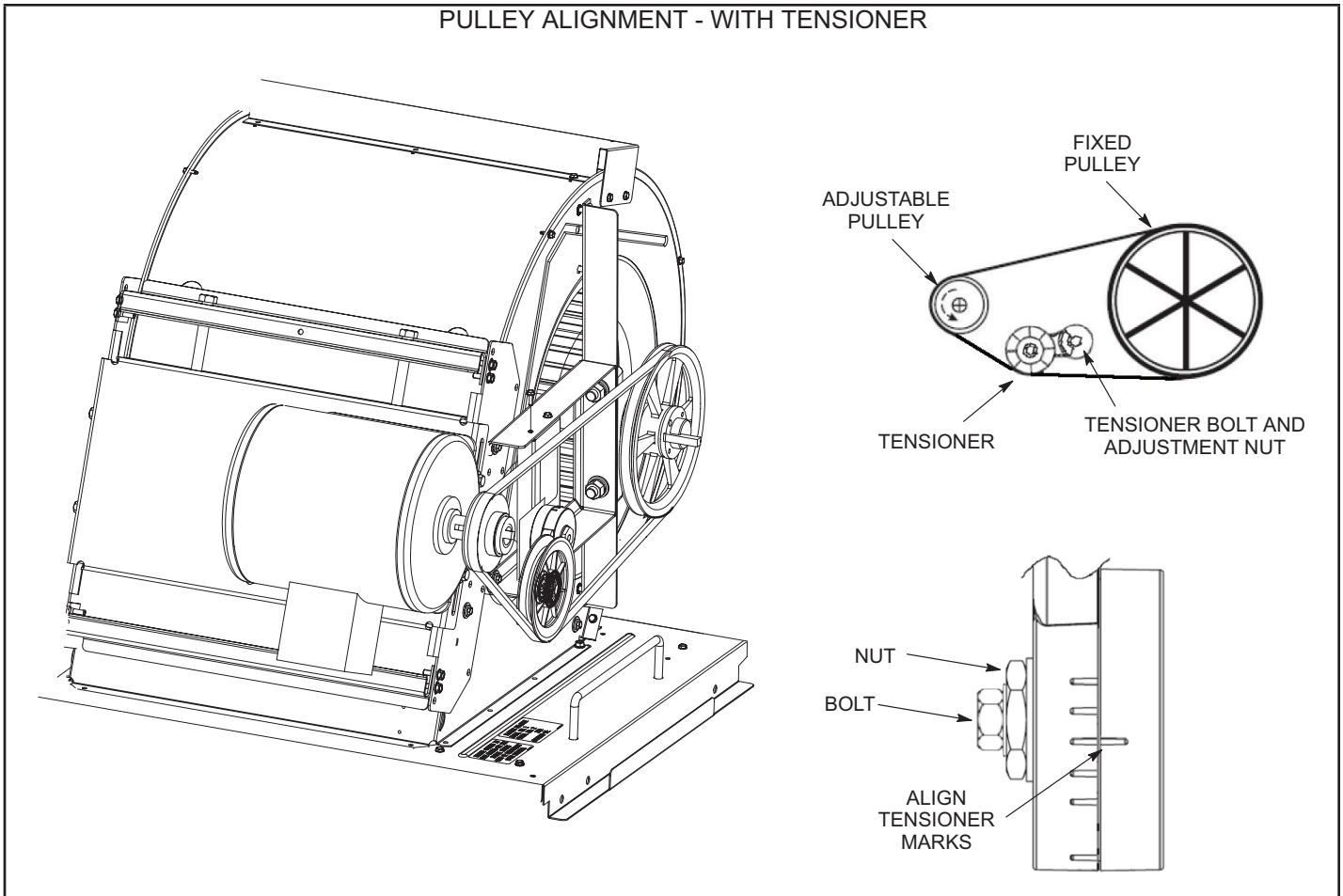


FIGURE 24

**Blowers Equipped With Belt Tensioner**

- 1 - Loosen the bolt in the center of the tensioner. See FIGURE 24.
- 2 - Place belt over all three pulleys.
- 3 - Using a 15/16" wrench, turn the tensioner nut until marks align as shown in figure 18.
- 4 - Hold the tensioner with marks aligned and tighten the bolt to 23 ft.lbs. using the 9/16" wrench.

**E-Check Belt Tension**

Overtensioning belts shortens belt and bearing life. Check belt tension as follows:

- 1 - Measure span length X. See FIGURE 25.
- 2 - Apply perpendicular force to center of span (X) with enough pressure to deflect belt 1/64" for every inch of span length or 1.5mm per 100mm of span length.  
 Example: Deflection distance of a 40" span would be 40/64" or 5/8".  
 Example: Deflection distance of a 400mm span would be 6mm.

- 3 - Measure belt deflection force. For a used belt, the deflection force should be 5 lbs. (35kPa) . A new belt deflection force should be 7 lbs. (48kPa).  
 A force below these values indicates an undertensioned belt. A force above these values indicates an overtensioned belt.

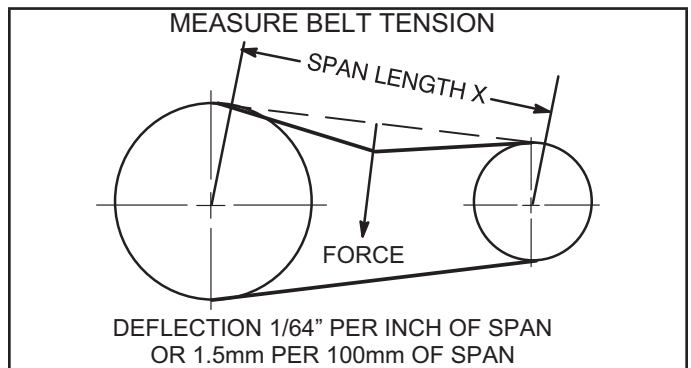


FIGURE 25

**F-Field-Furnished Blower Drives**

For field-furnished blower drives, use page 22 or page 23 to determine BHP and RPM required. Reference TABLE 5 to determine the manufacturer's model number.



# BLOWER DATA

BLOWER TABLE INCLUDES RESISTANCE FOR BASE UNIT ONLY WITH DRY INDOOR COIL & AIR FILTERS IN PLACE. FOR ALL UNITS ADD:

1 - Wet indoor coil air resistance of selected unit. 2 - Any factory installed options air resistance (heat section, Economizer, etc.) 3 - Any field installed accessories air resistance (heat section, duct resistance, diffuser, etc.)

Then determine from blower table blower motor output and drive required. See page 22 for wet coil and option/accessory air resistance data.

See page 22 for wet coil and option/accessory air resistance data.

See page 22 for factory installed drive kit specifications.

## MINIMUM AIR VOLUME REQUIRED FOR DIFFERENT GAS HEAT SIZES

Low (L), Standard (S) and Medium Heat (M) - 4500 cfm minimum. High Heat (H) - 5125 cfm minimum

## MINIMUM AIR VOLUME REQUIRED FOR USE WITH OPTIONAL ELECTRIC HEAT

LCM units with 15-60KW electric heat require 5200 cfm minimum air; units with 90KW require 6000 cfm minimum air.

Air Volume cfm	TOTAL STATIC PRESSURE - Inches Water Gauge (Pa)																											
	0.20		0.40		0.60		0.80		1.00		1.20		1.40		1.60		1.80		2.00		2.20		2.40		2.60			
	RPM	BHP	RPM	BHP	RPM	BHP	RPM	BHP	RPM	BHP	RPM	BHP	RPM	BHP	RPM	BHP	RPM	BHP	RPM	BHP	RPM	BHP	RPM	BHP	RPM	BHP	RPM	BHP
2750	385	0.3	505	0.5	600	0.7	680	0.9	755	1.1	820	1.3	885	1.7	950	2.1	1005	2.55	1060	3	1110	3.3	1160	3.85	1205	4.15	1250	4.45
3000	395	0.35	515	0.55	610	0.75	685	1	760	1.2	825	1.45	885	1.7	950	2.1	1005	2.55	1060	3	1110	3.3	1160	3.85	1205	4.15	1250	4.45
3250	405	0.4	520	0.6	615	0.85	695	1.1	765	1.3	830	1.6	890	1.85	950	2.1	1005	2.55	1060	3	1110	3.3	1160	3.85	1205	4.15	1250	4.45
3500	415	0.45	530	0.7	620	0.95	700	1.2	775	1.45	840	1.7	900	2	955	2.25	1005	2.55	1060	3	1110	3.3	1160	3.85	1205	4.15	1250	4.45
3750	425	0.5	540	0.75	630	1.05	710	1.3	780	1.6	845	1.85	905	2.15	960	2.45	1010	2.7	1060	3	1110	3.3	1160	3.85	1205	4.15	1250	4.45
4000	435	0.55	545	0.85	635	1.1	715	1.4	785	1.7	850	2	910	2.3	965	2.6	1020	2.9	1070	3.25	1115	3.55	1160	3.85	1205	4.15	1250	4.45
4250	445	0.6	555	0.9	645	1.25	725	1.55	795	1.85	855	2.15	915	2.45	970	2.8	1025	3.1	1075	3.45	1120	3.75	1165	4.1	1210	4.45	1250	4.45
4500	455	0.7	565	1	655	1.35	730	1.65	800	2	865	2.35	925	2.65	980	3	1030	3.3	1080	3.65	1130	4.05	1175	4.35	1215	4.7	1250	4.7
4750	470	0.75	575	1.1	660	1.45	740	1.8	810	2.15	870	2.5	930	2.85	985	3.2	1040	3.55	1085	3.9	1135	4.25	1180	4.65	1225	5	1250	5
5000	480	0.85	585	1.25	670	1.6	750	1.95	815	2.3	880	2.7	940	3.05	995	3.4	1045	3.8	1095	4.15	1140	4.5	1185	4.9	1230	5.3	1250	5.3
5250	495	0.95	595	1.35	680	1.7	755	2.1	825	2.5	890	2.9	945	3.25	1000	3.65	1050	4	1100	4.4	1150	4.8	1195	5.2	1235	5.6	1250	5.6
5500	505	1.05	605	1.45	690	1.85	765	2.25	835	2.65	895	3.05	955	3.45	1010	3.85	1060	4.25	1110	4.7	1155	5.1	1200	5.5	1240	5.9	1250	5.9
5750	520	1.15	615	1.6	700	2	775	2.45	840	2.85	905	3.25	960	3.65	1015	4.1	1065	4.5	1115	4.95	1160	5.35	1205	5.8	1250	6.25	1250	6.25
6000	530	1.3	630	1.75	710	2.15	785	2.6	850	3.05	910	3.45	970	3.9	1025	4.35	1075	4.8	1120	5.2	1170	5.65	1215	6.1	1255	6.55	1250	6.55
6250	545	1.4	640	1.9	720	2.35	795	2.8	860	3.25	920	3.7	975	4.15	1030	4.6	1080	5.05	1130	5.5	1175	5.95	1220	6.45	1265	6.9	1250	6.9
6500	560	1.55	650	2.05	730	2.5	805	3	870	3.45	930	3.95	985	4.4	1040	4.85	1090	5.35	1140	5.85	1185	6.3	1225	6.75	1270	7.25	1250	7.25
6750	570	1.7	665	2.2	745	2.7	815	3.2	880	3.7	940	4.2	995	4.65	1045	5.1	1095	5.6	1145	6.1	1190	6.6	1235	7.1	1275	7.6	1250	7.6
7000	585	1.85	675	2.35	755	2.9	825	3.4	890	3.95	950	4.45	1005	4.95	1055	5.4	1105	5.95	1155	6.45	1200	6.95	1240	7.45	1285	8	1250	8
7250	600	2	690	2.6	765	3.1	835	3.65	900	4.15	955	4.65	1015	5.25	1065	5.75	1115	6.25	1160	6.75	1205	7.3	1250	7.85	1290	8.35	1250	8.35
7500	615	2.2	700	2.75	775	3.3	845	3.85	910	4.45	965	4.95	1020	5.5	1075	6.05	1125	6.6	1170	7.15	1215	7.65	1260	8.25	1300	8.75	1250	8.75
7750	630	2.4	715	3	790	3.55	855	4.1	920	4.7	975	5.25	1030	5.8	1080	6.35	1130	6.9	1180	7.5	1225	8.05	1265	8.6	1305	9.15	1250	9.15
8000	640	2.55	725	3.2	800	3.8	865	4.35	930	4.95	985	5.5	1040	6.1	1090	6.7	1140	7.25	1185	7.85	1230	8.4	1275	9	1315	9.6	1250	9.6
8250	655	2.8	740	3.4	810	4	880	4.65	940	5.25	995	5.85	1050	6.45	1100	7.05	1150	7.65	1195	8.25	1240	8.85	1280	9.4	1325	10.05	1250	10.05
8500	670	3	750	3.65	825	4.3	890	4.9	950	5.55	1005	6.15	1060	6.8	1110	7.4	1160	8.05	1205	8.65	1250	9.25	1290	9.85	1330	10.45	1250	10.45
8750	685	3.25	765	3.9	835	4.55	900	5.2	960	5.85	1015	6.45	1070	7.15	1120	7.75	1165	8.35	1215	9.05	1255	9.65	1300	10.3	1330	10.3	1250	10.3
9000	700	3.5	780	4.2	850	4.85	910	5.5	970	6.15	1025	6.8	1080	7.5	1130	8.15	1175	8.75	1220	9.4	1265	10.1	1310	10.8	1330	10.8	1250	10.8
9250	715	3.75	790	4.45	860	5.15	925	5.85	985	6.55	1040	7.2	1090	7.85	1140	8.55	1185	9.2	1230	9.85	1275	10.55	1315	11.2	1330	11.2	1250	11.2
9500	730	4	805	4.75	875	5.45	935	6.15	995	6.9	1050	7.6	1100	8.25	1150	8.95	1195	9.6	1240	10.3	1285	11.05	1315	11.5	1330	11.5	1250	11.5
9750	745	4.3	820	5.05	885	5.75	950	6.55	1005	7.2	1060	7.95	1110	8.65	1160	9.4	1205	10.05	1250	10.85	1295	11.5	1315	11.5	1330	11.5	1250	11.5
10,000	760	4.6	835	5.4	900	6.15	960	6.85	1015	7.6	1070	8.35	1120	9.05	1170	9.8	1215	10.5	1260	11.25	1295	11.5	1315	11.5	1330	11.5	1250	11.5
10,250	775	4.9	845	5.65	910	6.45	970	7.2	1030	8	1080	8.75	1135	9.55	1180	10.25	1225	11	1265	11.25	1295	11.5	1315	11.5	1330	11.5	1250	11.5
10,500	790	5.2	860	6	925	6.85	985	7.65	1040	8.4	1095	9.2	1145	10	1190	10.7	1235	11.45	1275	11.45	1295	11.5	1315	11.5	1330	11.5	1250	11.5
10,750	805	5.55	875	6.4	940	7.25	1000	8.05	1055	8.85	1105	9.65	1155	10.45	1200	11.2	1245	11.2	1285	11.2	1295	11.5	1315	11.5	1330	11.5	1250	11.5
11,000	820	5.9	890	6.8	950	7.6	1010	8.45	1065	9.3	1115	10.05	1165	10.9	1210	11.65	1255	11.2	1295	11.2	1295	11.5	1315	11.5	1330	11.5	1250	11.5

## BLOWER DATA

### FACTORY INSTALLED BELT DRIVE KIT SPECIFICATIONS

Nominal hp	Maximum hp	Drive Kit Number	RPM Range
3	3.45	1	535 - 725
3	3.45	2	710 - 965
5	5.75	3	685 - 856
5	5.75	4	850 - 1045
5	5.75	5	945 - 1185
7.5	8.63	6	850 - 1045
7.5	8.63	7	945 - 1185
7.5	8.63	8	1045 - 1285
10	11.50	7	945 - 1185
10	11.50	10	1045 - 1285
10	11.50	11	1135 - 1330

**NOTE** - Using total air volume and system static pressure requirements determine from blower performance tables rpm and motor output required. Maximum usable output of motors furnished are shown. In Canada, nominal motor output is also maximum usable motor output. If motors of comparable output are used, be sure to keep within the service factor limitations outlined on the motor nameplate.

**NOTE** - Units equipped with Multi-Stage Air Volume option are limited to a motor service factor of 1.0.

### FACTORY INSTALLED OPTIONS/FIELD INSTALLED ACCESSORY AIR RESISTANCE

Air Volume cfm	Wet Indoor Coil		Condensator Reheat Coil	Gas Heat Exchanger			Electric Heat	Econo-mizer	Filters		Horizontal Roof Curb	
	156, 180	210, 240, 300		Low/Standard Heat	Medium Heat	High Heat			156 thru 240U	300U		
	in. w.g.	in. w.g.	in. w.g.	in. w.g.	in. w.g.	in. w.g.	in. w.g.	in. w.g.	MERV 8	MERV 13	in. w.g.	in. w.g.
2750	0.01	0.02	0.01	0.02	0.04	0.05	---	---	0.01	0.03	0.03	-
3000	0.01	0.02	0.01	0.03	0.04	0.05	---	---	0.01	0.03	0.04	-
3250	0.01	0.03	0.01	0.03	0.05	0.06	---	---	0.01	0.04	0.04	0.01
3500	0.01	0.03	0.02	0.03	0.05	0.06	---	---	0.01	0.04	0.05	0.01
3750	0.01	0.03	0.02	0.04	0.06	0.07	---	---	0.01	0.04	0.05	0.01
4000	0.02	0.04	0.02	0.04	0.06	0.07	---	---	0.01	0.04	0.06	0.02
4250	0.02	0.04	0.02	0.04	0.06	0.08	---	---	0.01	0.05	0.07	0.02
4500	0.02	0.05	0.02	0.05	0.07	0.09	---	---	0.01	0.05	0.07	0.02
4750	0.02	0.05	0.02	0.05	0.08	0.1	---	---	0.02	0.05	0.08	0.03
5000	0.02	0.05	0.02	0.05	0.09	0.11	---	---	0.02	0.06	0.08	0.03
5250	0.02	0.06	0.03	0.06	0.1	0.12	---	---	0.02	0.06	0.09	0.04
5500	0.02	0.07	0.03	0.06	0.1	0.13	---	---	0.02	0.06	0.1	0.04
5750	0.03	0.07	0.03	0.06	0.11	0.14	---	---	0.02	0.07	0.11	0.05
6000	0.03	0.08	0.03	0.07	0.12	0.15	0.01	---	0.03	0.07	0.11	0.06
6250	0.03	0.08	0.03	0.07	0.12	0.16	0.01	0.01	0.03	0.07	0.12	0.07
6500	0.03	0.09	0.04	0.08	0.13	0.17	0.01	0.02	0.03	0.08	0.13	0.08
6750	0.04	0.1	0.04	0.08	0.14	0.18	0.01	0.03	0.03	0.08	0.14	0.08
7000	0.04	0.1	0.04	0.09	0.15	0.19	0.01	0.04	0.04	0.08	0.15	0.09
7250	0.04	0.11	0.04	0.09	0.16	0.2	0.01	0.05	0.04	0.09	0.16	0.1
7500	0.05	0.12	0.05	0.1	0.17	0.21	0.01	0.06	0.04	0.09	0.17	0.11
8000	0.05	0.13	0.05	0.11	0.19	0.24	0.02	0.09	0.05	0.1	0.19	0.13
8500	0.06	0.15	0.05	0.12	0.2	0.26	0.02	0.11	0.05	0.1	0.21	0.15
9000	0.07	0.16	0.06	0.13	0.23	0.29	0.04	0.14	0.06	0.11	0.24	0.17
9500	0.08	0.18	0.07	0.14	0.25	0.32	0.05	0.16	0.07	0.12	0.26	0.19
10,000	0.08	0.2	0.07	0.16	0.27	0.35	0.06	0.19	0.07	0.12	0.29	0.21
10,500	0.09	0.22	0.08	0.17	0.3	0.38	0.09	0.22	0.08	0.13	0.31	0.24
11,000	0.11	0.24	0.08	0.18	0.31	0.4	0.11	0.25	0.09	0.14	0.34	0.27

**TABLE 5  
MANUFACTURER'S NUMBERS**

Drive No.	H.P.	DRIVE COMPONENTS											
		RPM		ADJUSTABLE SHEAVE		FIXED SHEAVE		BELTS (STD.)		BELTS (WITH TENSIONER)		SPLIT BUSHING	
		Min.	Max.	Supplier No,	OEM Part No.	Supplier No,	OEM Part No.	Supplier No,	OEM Part No.	Supplier No,	OEM Part No.	Supplier No,	OEM Part No.
1	3	535	725	1VP40x7/8	79J0301	BK95 x 1-3/16	105617-02	BX59	59A5001	BX60	100245-10	N/A	N/A
2	3	710	965	1VP40x7/8	79J0301	BK72 x 1-3/16	105617-01	BX55	63K0501	BX57	78L5301	N/A	N/A
3	5	685	865	1VP50x1-1/8	P-8-1977	BK100 x 1-3/16	105617-03	BX61	93J9801	5VX660	100245-20	N/A	N/A
4	5	850	1045	1VP65x1-1/8	100239-03	BK110H	100788-06	BX65	100245-08	BX66	97J5901	H-1-3/16	105616-02
5	5	945	1185	1VP60x1-1/8	41C1301	BK90H x 1-7/16	100788-04	BX61	93J9801	BX62	57A7701	H-1-3/16	105616-02
6	7.5	850	1045	1VP65x1-3/8	78M7101	BK110H	100788-06	BX66	97J5901	BX67	100245-09	H-1-3/16	105616-02
7	7.5 & 10	945	1185	1VP60x1-3/8	78L5501	BK90H x 1-7/16	100788-04	BX62	57A7701	BX64	97J5801	H-1-3/16	105616-02
8	7.5	1045	1285	1VP65x1-3/8	78M7101	BK90H x 1-7/16	100788-04	BX64	97J5801	5VX670	100245-21	H-1-3/16	105616-02
10	10	1045	1285	1VP65x1-3/8	78M7101	1B5V86	78M8301	5VX660	100245-20	5VX670	100245-21	B-1-3/16	105616-01
11	10	1105	1330	1VP71 X 1-3/8	100239-06	1B5V90	100240-02	5VX660	100245-35	5VX660	100245-20	B-1-3/16	105616-01

## Refrigerant Leak Detection System

### A-System Test

- 1 - Initiate Refrigerant Leak Detection System Test by using the following mobile service app menu path:

**RTU MENU > COMPONENT TEST > LEAK DETECTION > START TEST**

- 2 - Ensure that indoor blower, outdoor fan, and combustion air blower (LGT only) are energized.

## Cooling Start-Up

**IMPORTANT**-The crankcase heater must be energized for 24 hours before attempting to start compressor. Set thermostat so there is no demand to prevent compressors from cycling. Apply power to unit.

**NOTE** - These units must not be used as a "construction heater" at any time during any phase of construction. Very low return air temperatures, harmful vapors and misplacement of the filters will damage the unit and its efficiency. Additionally, a unit which will be subject to cold temperatures when not in operation must have a vapor barrier installed to seal the duct connections. Failure to protect the unit from moisture laden air or harmful vapors (generated from the construction process and temporary combustion heating equipment) will cause corrosive condensation within the unit. Failure to properly protect the unit in this situation will cause electrical and electronic component failure and could affect the unit warranty status.

### A-Preliminary Checks

- 1 - Make sure that unit is installed in accordance with the installation instructions and applicable codes.
- 2 - Inspect all electrical wiring, both field and factory-installed, for loose connections. Tighten as required.
- 3 - Check to ensure that refrigerant lines do not rub against the cabinet or against other refrigerant lines.
- 4 - Check voltage at disconnect switch. Voltage must be within range listed on nameplate. If not, consult power company and have voltage condition corrected before starting unit.
- 5 - Make sure filters are in place before start-up.

### B-Start-Up

*Supply Air Staged Blower - Refer to the Multi-Staged Air Volume Start-Up section.*

- 1 - Initiate first and second stage cooling demands using this mobile service app menu path:

**SERVICE > TEST > COOLING > COOL4**

Instructions provided with the thermostat may also be used to initiate cooling.

- 2 - First-stage thermostat demand will energize indoor blower in Low Cooling CFM. Second-stage thermostat demand will energize indoor blower in High Cooling CFM. Both demands energize compressor 1 (variable speed compressor). The remaining compressors will be energized to modulate the discharge air temperature.

- 3 - 156, 180 -

Units contain three refrigerant circuits or systems. See FIGURE 26.

210, 240, 300 -

Units contain four refrigerant circuits or systems. See FIGURE 27.

- 4 - Each refrigerant circuit is separately charged with R454B refrigerant. See unit rating plate for correct amount of charge.
- 5 - Refer to the Refrigerant Check and Charge section to check refrigerant charge.

### C-R454B Refrigerant

Units charged with R454B refrigerant operate at lower pressures than R410A. The expansion valve and liquid line dryer provided with the unit are approved for use with R454B.

R454B refrigerant is stored in a gray cylinder.

## IMPORTANT

Mineral oils are not compatible with R454B. If oil must be added, it must be a polyol ester oil.

Manifold gauge sets used with systems charged with R454B refrigerant must be capable of handling various system operating pressures. The gauges should be rated for use with pressures of 0-800 on the high side and a low side of 30" vacuum to 250 psi with dampened speed to 500 psi. Gauge hoses must be rated for use at up to 800 psi of pressure with a 4000 psi burst rating.

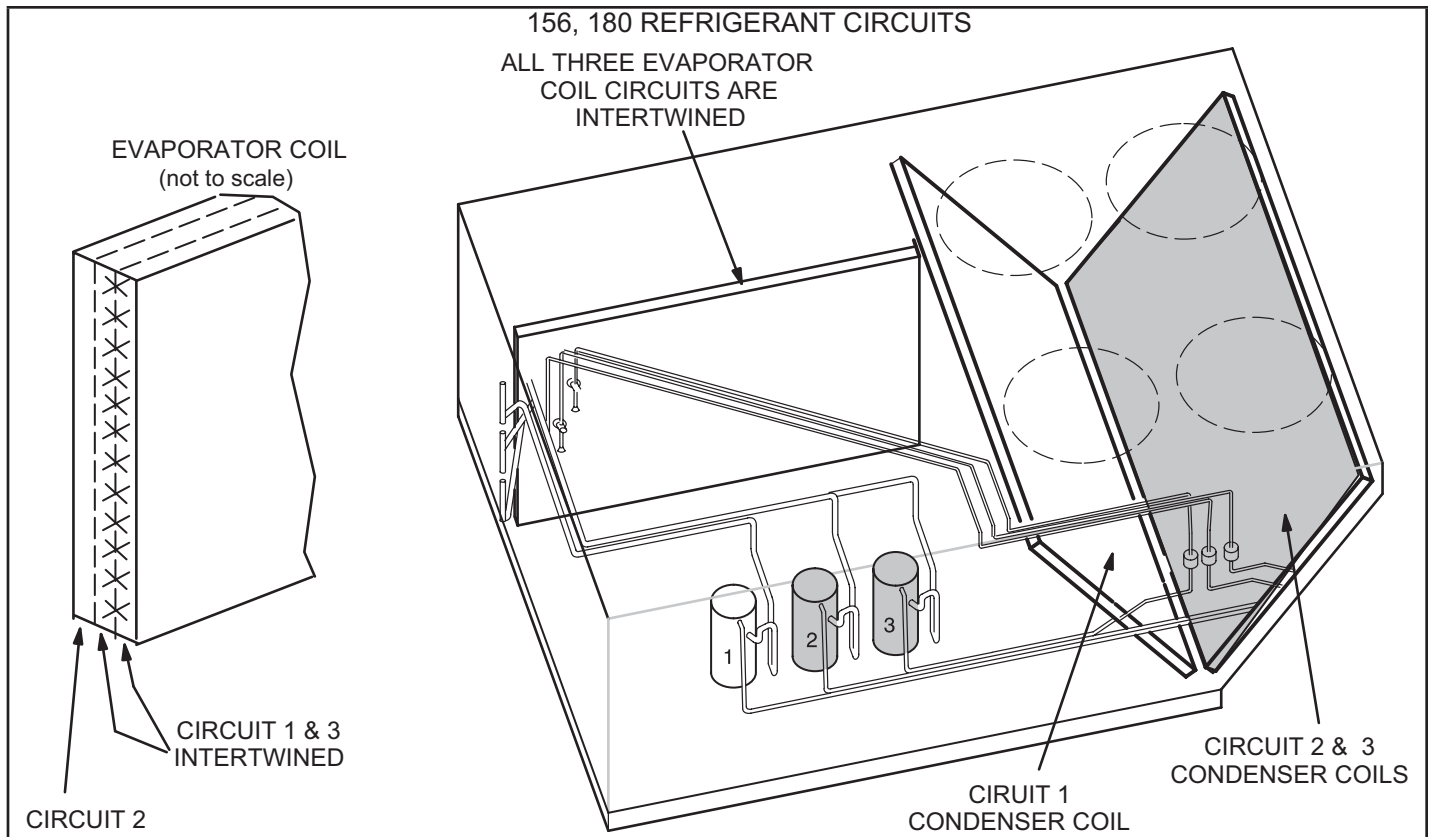


FIGURE 26

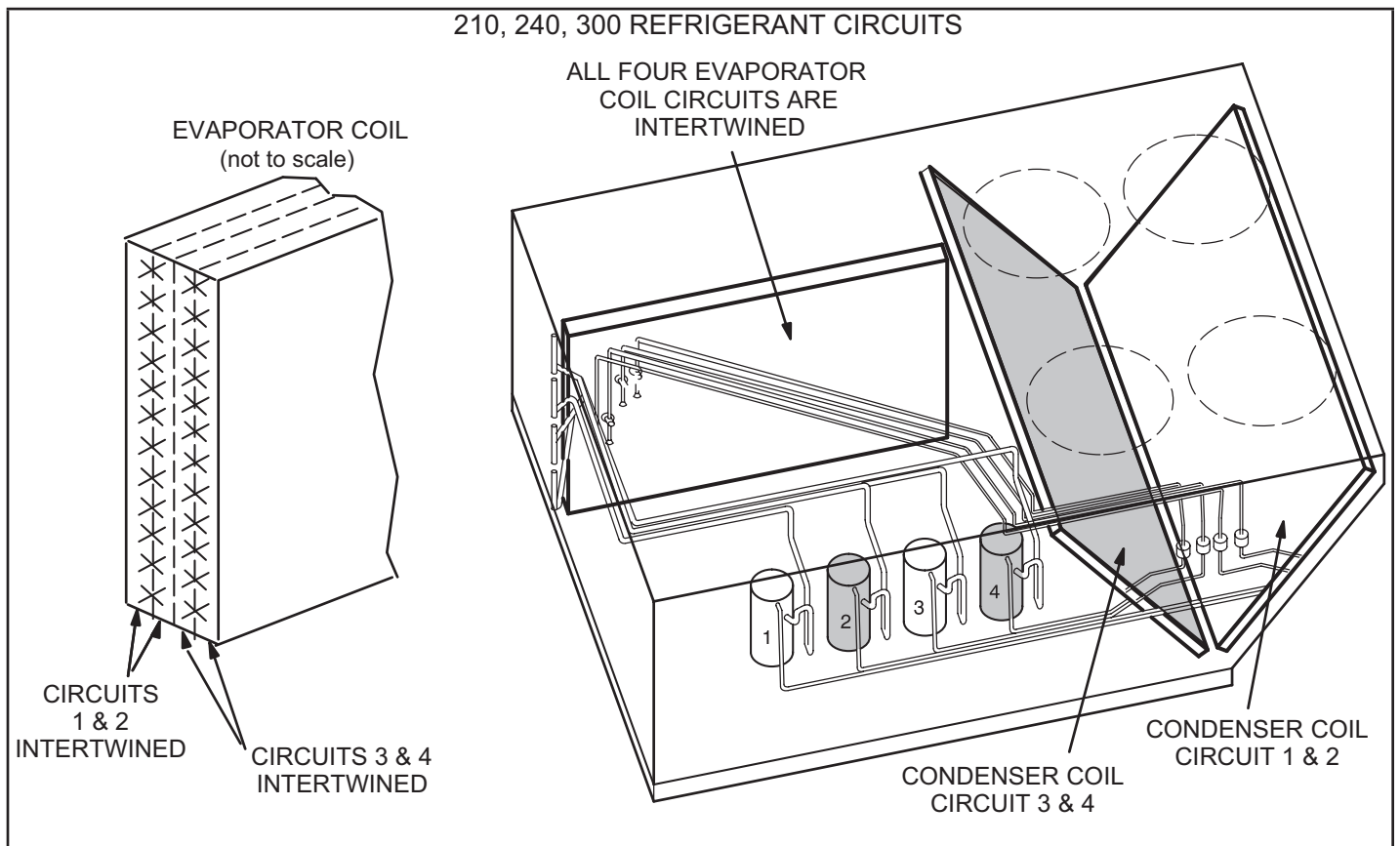


FIGURE 27



**D-Refrigerant Charge and Check - All Aluminum Coil**  
**WARNING-Do not exceed nameplate charge under any condition.**

This unit is factory charged and should require no further adjustment. If the system requires additional refrigerant, reclaim the charge, evacuate the system, and add required nameplate charge.

**NOTE - System charging is not recommended below 60cF (15cC). In temperatures below 60cF (15cC), the charge must be weighed into the system.**

If weighing facilities are not available, or to check the charge, use the following procedure:

**IMPORTANT - Charge unit in normal cooling mode.**

- 1 - Attach gauge manifolds to discharge and suction lines. With the economizer disabled, operate the unit in **cooling mode at high speed** using the following mobile service app menu path:

**SERVICE>TEST>COOL>COOL 4**

- 2 - Use a thermometer to accurately measure the outdoor ambient temperature.
- 3 - Apply the outdoor temperature to TABLE 5 through TABLE 14 to determine normal operating pressures. Pressures are listed for sea level applications at 80°F dry bulb and 67°F wet bulb return air.
- 4 - Compare the normal operating pressures to the pressures obtained from the gauges.

Minor variations in the pressures may be expected due to differences in installations. Significant differences could mean that the system is not properly charged or that a problem exists with some component in the system. Correct any system problems before proceeding.

- 5 - If discharge pressure is high, remove refrigerant from the system. If discharge pressure is low, add refrigerant to the system.
  - Add or remove charge in increments.
  - Allow the system to stabilize each time refrigerant is added or removed.

- 6 - Confirm charge amount using liquid temperature plots. Fine tune charge amount(s) to match liquid temperature plots as needed per the next section.

**E-Charge Confirmation and Fine Tuning - Liquid Temperature Check**

**NOTE - Pressures are listed for sea level applications.**

- 1 - Use the same thermometer to accurately measure the liquid temperature (in the outdoor section).
  - If measured liquid temperature is higher than the target liquid temperature, add refrigerant to the system.
  - If measured liquid temperature is lower than the target liquid temperature, recover some refrigerant from the system.

- 2 - Add or remove charge in increments. Allow the system to stabilize each time refrigerant is added or removed.
- 3 - Continue the process until measured liquid temperature agrees with the target liquid temperature. Do not go below the target liquid temperature when adjusting charge. Note that suction pressure can change as charge is adjusted.
- 4 - Example: At 95°F outdoor ambient and a measured suction pressure of 130psig, the target liquid temperature is 98°F. For a measured liquid temperature of 106°F, add charge in increments until measured liquid temperature agrees with the target liquid temperature.

Refrigerant Charge R-454B		
Unit	M <sub>c</sub> (lbs)	M <sub>c</sub> (kg)
LCM/LGM156 Stg 1	6.19	2.81
LCM/LGM156 Stg 2	5.31	2.41
LCM/LGM156 Stg 3	5.69	2.58
LCM/LGM180 Stg 1	6.25	2.83
LCM/LGM180 Stg 2	6.13	2.78
LCM/LGM180 Stg 3	5.50	2.49
LCM/LGM210 Stg 1	5.88	2.66
LCM/LGM210 Stg 2	5.75	2.61
LCM/LGM210 Stg 3	5.00	2.27
LCM/LGM210 Stg 4	5.25	2.38
LCM/LGM240 Stg 1	6.06	2.75
LCM/LGM240 Stg 2	5.68	2.58
LCM/LGM240 Stg 3	5.12	2.32
LCM/LGM240 Stg 4	5.50	2.49
LCM/LGM300 Stg 1	6.75	3.06
LCM/LGM300 Stg 2	6.75	3.06
LCM/LGM300 Stg 3	6.19	2.81
LCM/LGM300 Stg 4	5.94	2.69

In addition to conventional charging procedures, the following requirements shall be followed.

- Ensure that contamination of different refrigerants does not occur when using charging equipment. Hoses or lines shall be as short as possible to minimize the amount of refrigerant contained in them.
- Cylinders shall be kept in an appropriate position according to the instructions.
- Ensure that the unit is earth grounded prior to charging the system with refrigerant.
- Label the system when charging is complete (if not already).
- Extreme care shall be taken not to overfill the unit.

Prior to recharging the system, it shall be pressure-tested with the appropriate purging gas. The system shall be leak-tested on completion of charging but prior to commissioning. A follow up leak test shall be carried out prior to leaving the site.



- When removing refrigerant from a system, either for servicing or decommissioning, it is recommended good practice that all refrigerants are removed safely.
- When transferring refrigerant into cylinders, ensure that only appropriate refrigerant recovery cylinders are employed. Ensure that the correct number of cylinders for holding the total system charge is available. All cylinders to be used are designated for the recovered refrigerant and labelled for that refrigerant (i. e. special cylinders for the recovery of refrigerant). Cylinders shall be complete with pressure-relief valve and associated shut-off valves in good working order. Empty recovery cylinders are evacuated and, if possible, cooled before recovery
- The recovery equipment shall be in good working order with a set of instructions concerning the equipment that is at hand and shall be suitable for the recovery of all appropriate refrigerants including, when applicable, flammable refrigerants. In addition, a set of calibrated weighing scales shall be available and in good working order. Hoses shall be complete with leak-free disconnect couplings and in good condition. Before using the recovery machine, check that it is in satisfactory working order, has been properly maintained and that any associated electrical components are sealed to prevent ignition in the event of a refrigerant release. Consult manufacturer if in doubt.
- The recovered refrigerant shall be returned to the refrigerant supplier in the correct recovery cylinder, and the relevant waste transfer note arranged. Do not mix refrigerants in recovery units and especially
- If compressors or compressor oils are to be removed, ensure that they have been evacuated to an acceptable level to make certain that flammable refrigerant does not remain within the lubricant. The evacuation process shall be carried out prior to returning the compressor to the suppliers. Only electric heating to the compressor body shall be employed to accelerate this process. When oil is drained from a system, it shall be carried out safely.

**NOTE** - System charging is not recommended below 60°F (15°C). In temperatures below 60°F (15°C), the charge must be weighed into the system.

If weighing facilities are not available, or to check the charge, use the following procedure:

- 1 - Make sure outdoor coil is clean. Attach gauge manifolds and operate unit at full CFM in cooling mode with economizer disabled until system stabilizes (approximately five minutes). Make sure all outdoor air dampers are closed.

- 2 - Compare the normal operating pressures to the pressures obtained from the gauges. Check unit components if there are significant differences.
- 3 - Measure the outdoor ambient temperature and the suction pressure. Refer to the charging curve to determine a target liquid temperature.

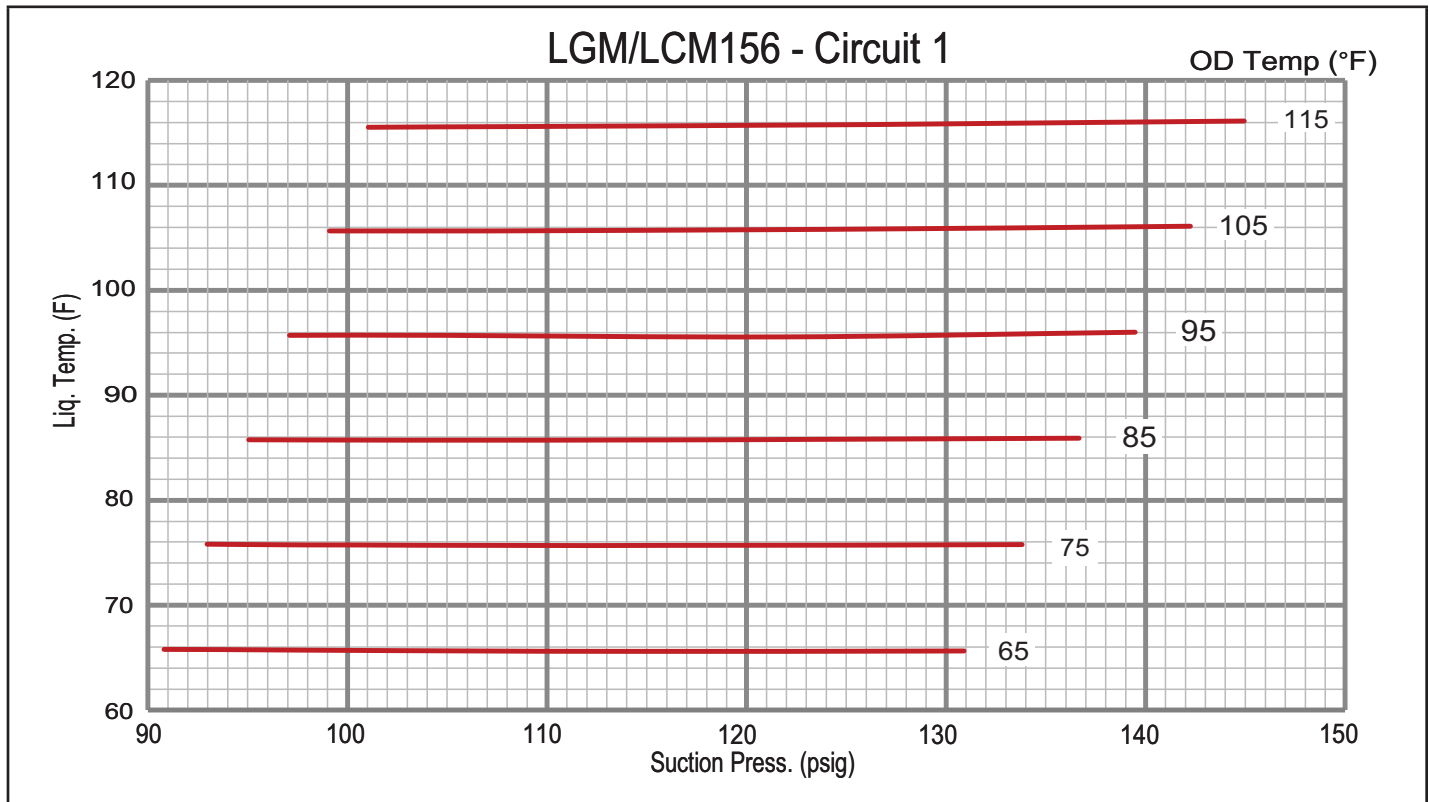
**NOTE** - Pressures are listed for sea level applications.

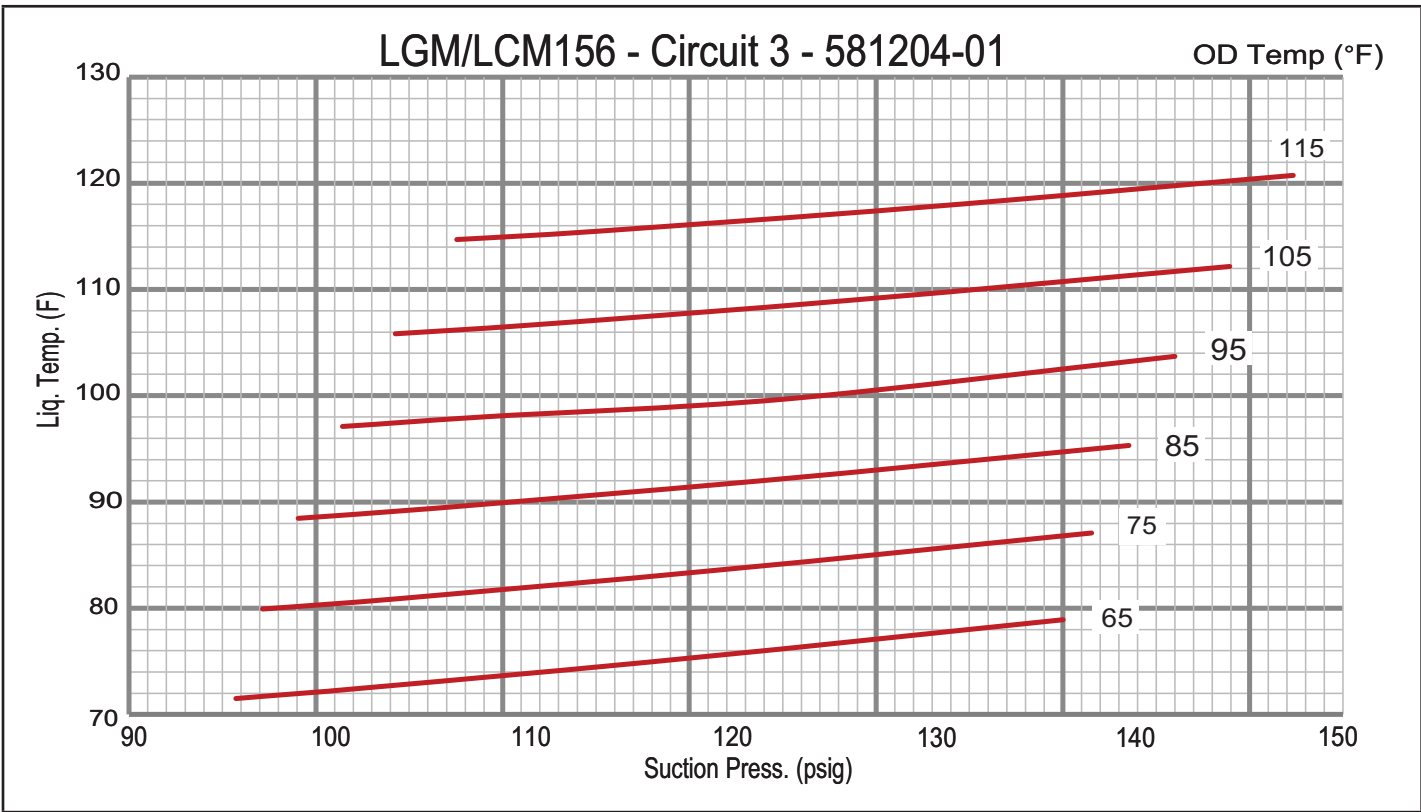
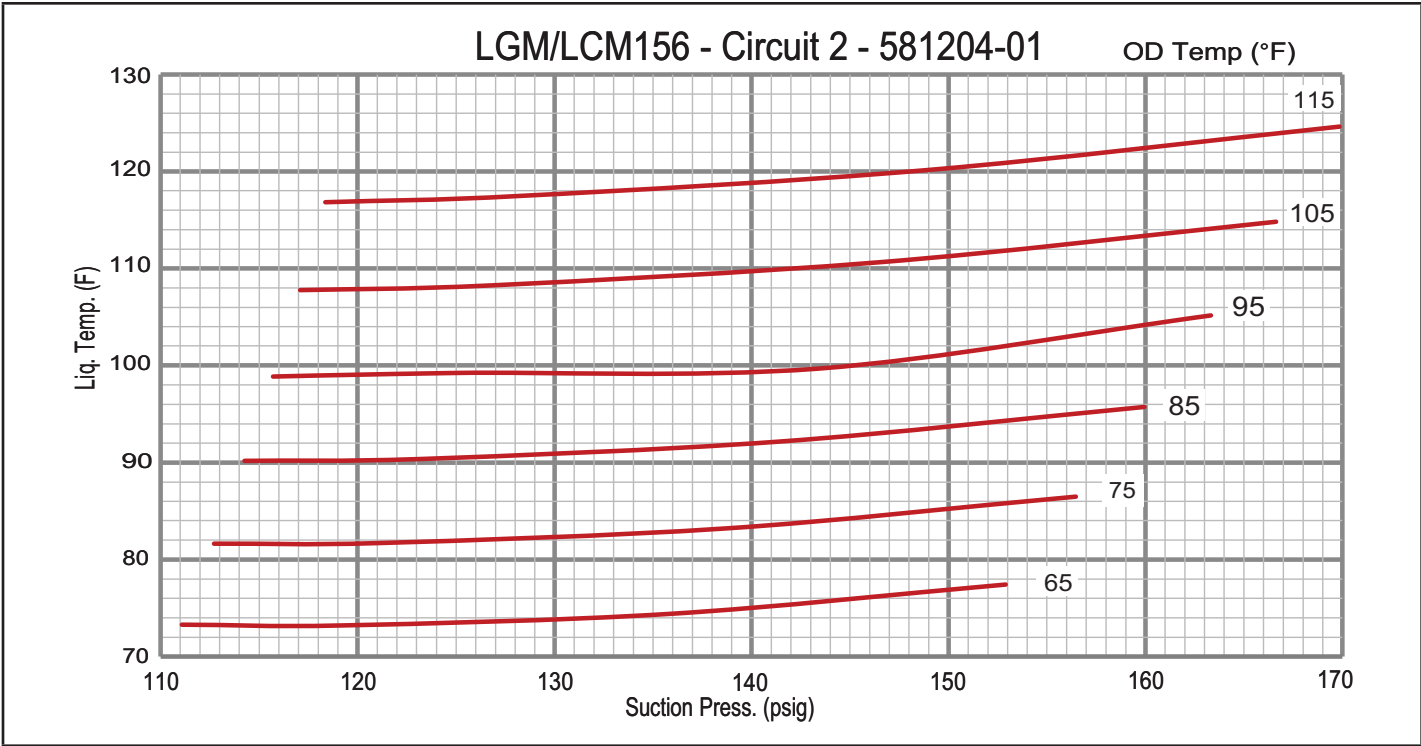
- 4 - Use the same thermometer to accurately measure the liquid temperature (in the outdoor section).
  - If measured liquid temperature is higher than the target liquid temperature, add refrigerant to the system.
  - If measured liquid temperature is lower than the target liquid temperature, recover some refrigerant from the system..
- 5 - Add or remove charge in increments. Allow the system to stabilize each time refrigerant is added or removed.
- 6 - Continue the process until measured liquid temperature agrees with the target liquid temperature. Do not go below the target liquid temperature when adjusting charge. Note that suction pressure can change as charge is adjusted.
- 7 - Example: At 95°F outdoor ambient and a measured suction pressure of 130psig, the target liquid temperature is 97°F. For a measured liquid temperature of 106°F, add charge in increments until measured liquid temperature agrees with the target liquid temperature.

**TABLE 6**

**LGM/LCM156 All-Aluminum OD Coil, No Reheat, Normal Operating Pressures - 581203-01**

	Outdoor Coil Entering Air Temperature											
	65°F		75°F		85°F		95°F		105°F		115°F	
	Suct (psig)	Disc (psig)	Suct (psig)	Disc (psig)	Suct (psig)	Disc (psig)	Suct (psig)	Disc (psig)	Suct (psig)	Disc (psig)	Suct (psig)	Disc (psig)
Circuit 1	91	211	93	244	95	282	97	324	99	371	101	422
	98	211	100	244	103	282	105	325	107	372	109	423
	114	213	116	247	119	286	122	328	124	376	126	428
	131	218	134	252	137	291	139	335	142	383	145	435
Circuit 2	111	216	113	252	114	293	116	338	117	388	118	441
	119	218	121	255	123	296	125	341	127	390	128	444
	136	223	139	259	141	300	143	346	146	395	149	449
	153	227	156	264	160	305	163	350	167	400	170	453
Circuit 3	96	217	97	253	99	293	101	336	104	384	108	435
	103	220	105	256	107	296	109	340	112	388	115	439
	120	225	122	261	124	302	125	346	129	395	132	447
	140	230	142	267	144	308	146	353	149	402	152	455

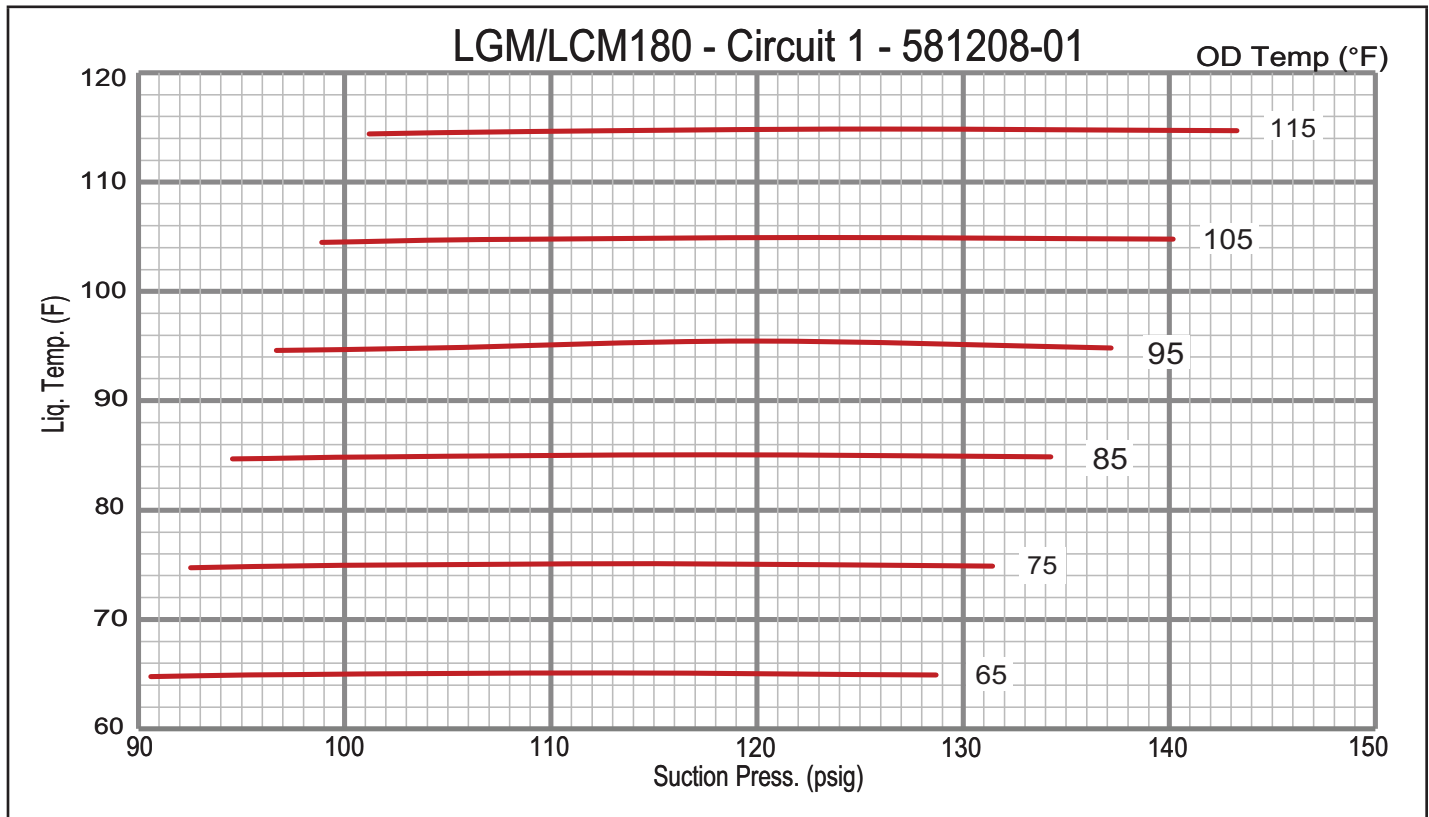


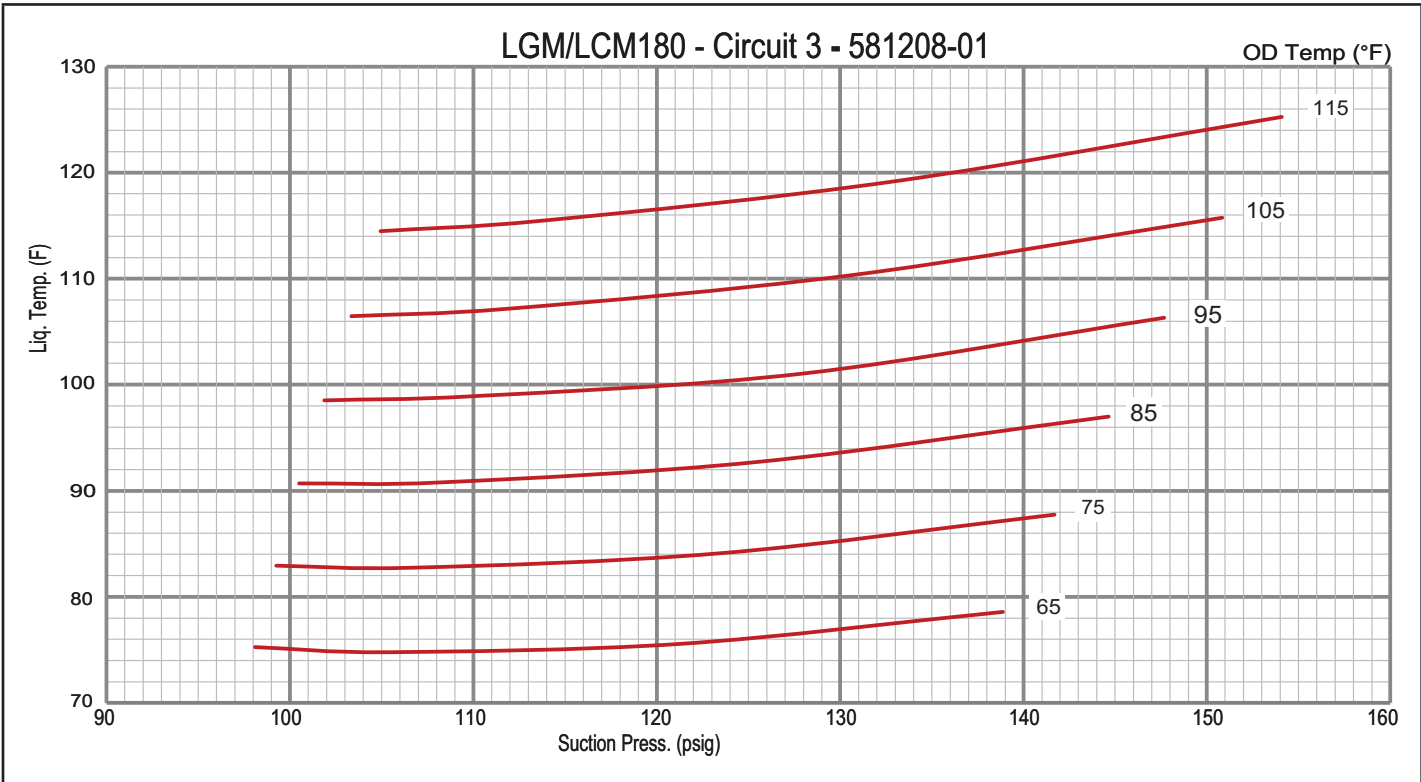
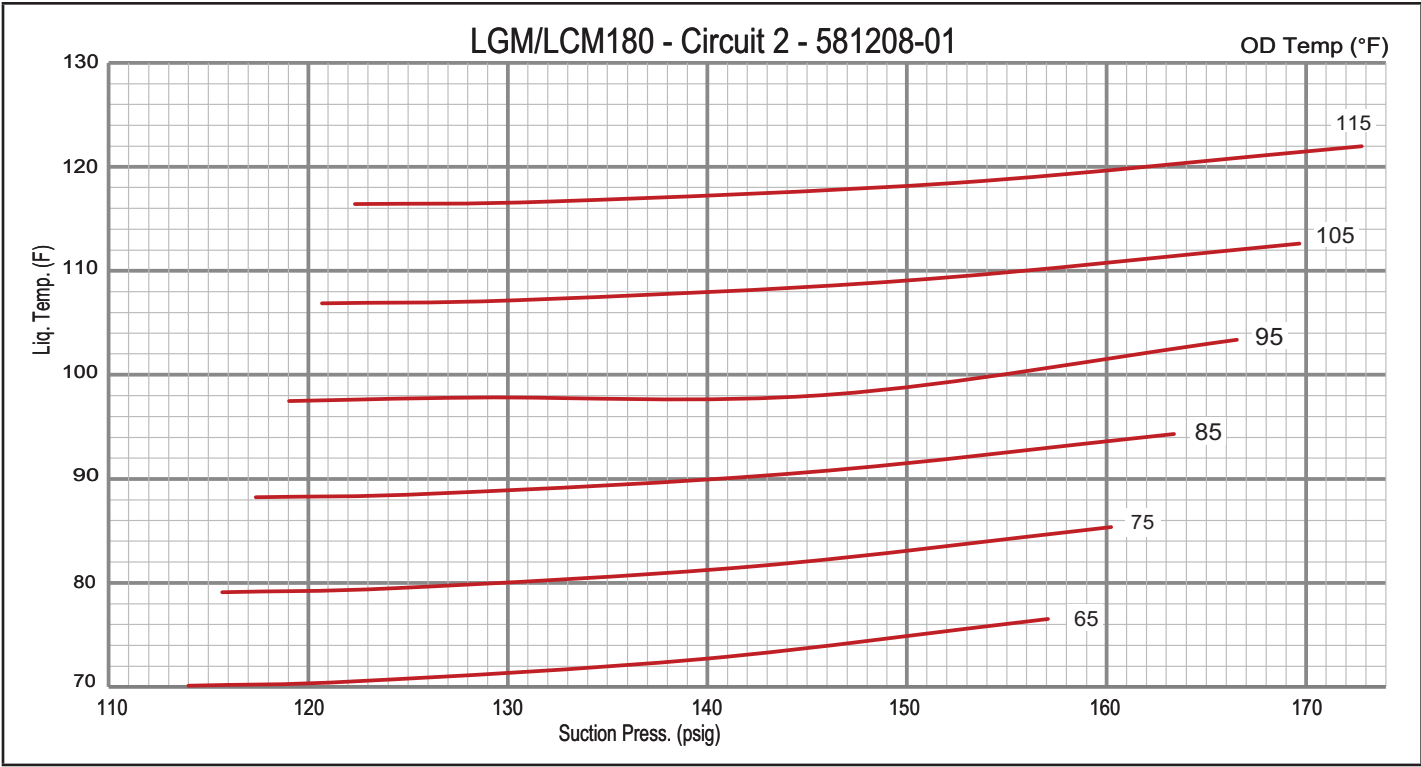


**TABLE 7**

**LGM/LCM180 All-Aluminum OD Coil, No Reheat, Normal Operating Pressures- 581207-01**

	Outdoor Coil Entering Air Temperature											
	65°F		75°F		85°F		95°F		105°F		115°F	
	Suct (psig)	Disc (psig)	Suct (psig)	Disc (psig)	Suct (psig)	Disc (psig)	Suct (psig)	Disc (psig)	Suct (psig)	Disc (psig)	Suct (psig)	Disc (psig)
Circuit 1	91	222	93	246	95	290	97	354	99	439	101	543
	98	227	100	249	102	292	104	354	107	437	109	540
	113	236	115	255	118	295	120	346	123	434	126	533
	129	245	131	261	134	297	137	353	140	429	143	526
Circuit 2	114	216	116	251	117	292	119	337	121	388	122	445
	123	219	125	254	127	294	129	340	130	391	132	447
	140	224	142	259	145	299	146	346	150	395	153	451
	157	228	160	263	163	303	167	348	170	398	173	454
Circuit 3	98	222	99	258	101	299	102	345	103	394	105	448
	105	226	107	262	108	303	110	348	112	398	114	452
	121	232	123	269	126	310	128	357	131	405	133	459
	139	238	142	275	145	315	148	361	151	410	154	465

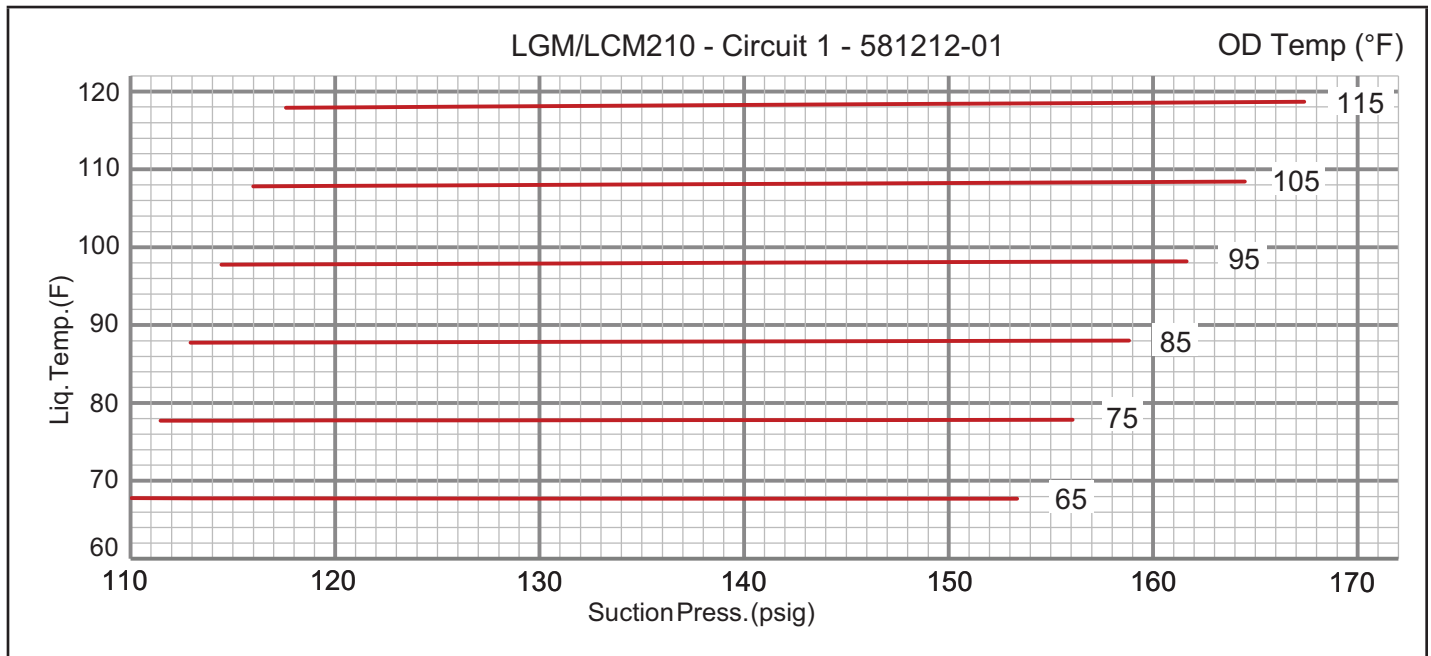




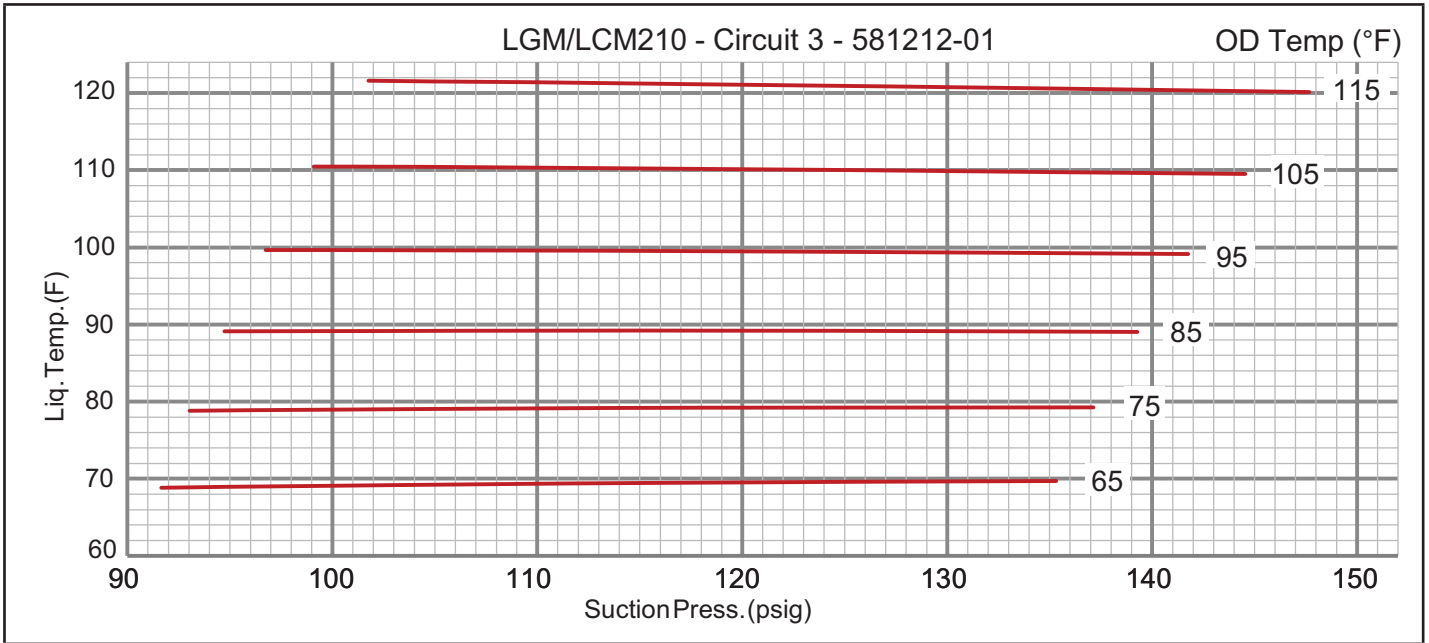
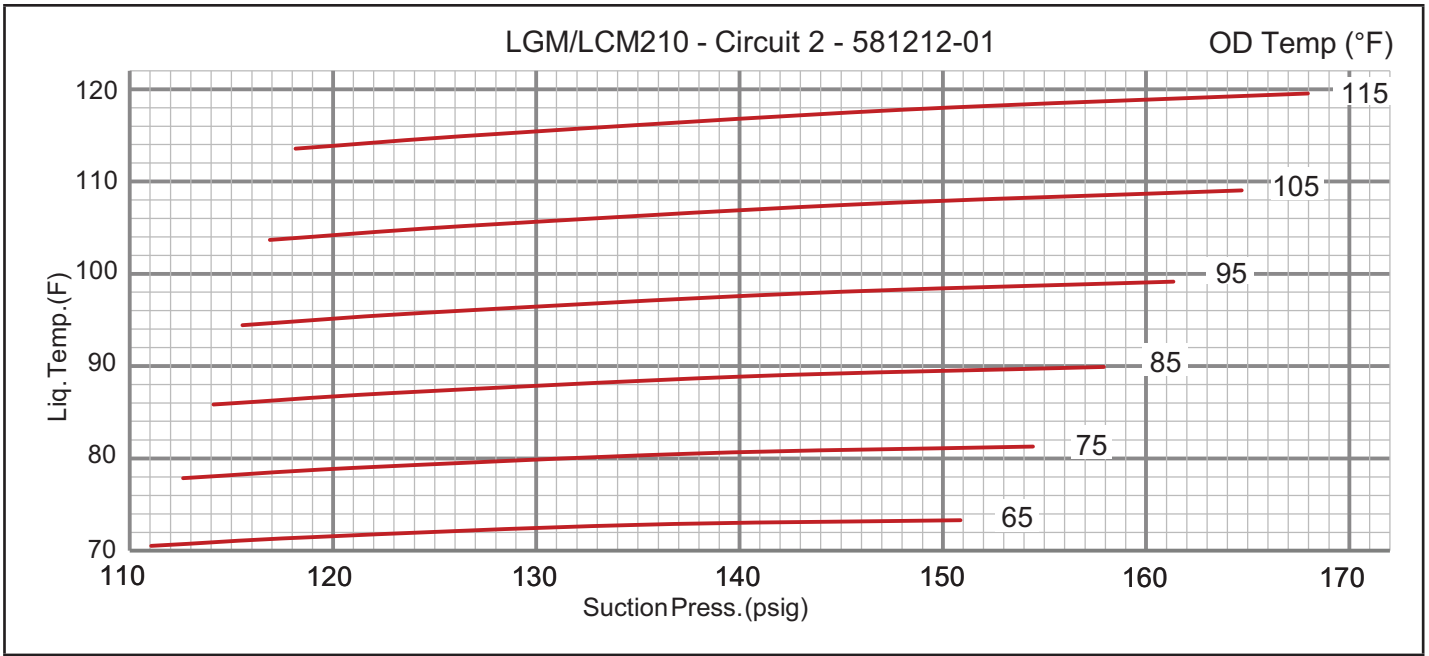
**TABLE 8**

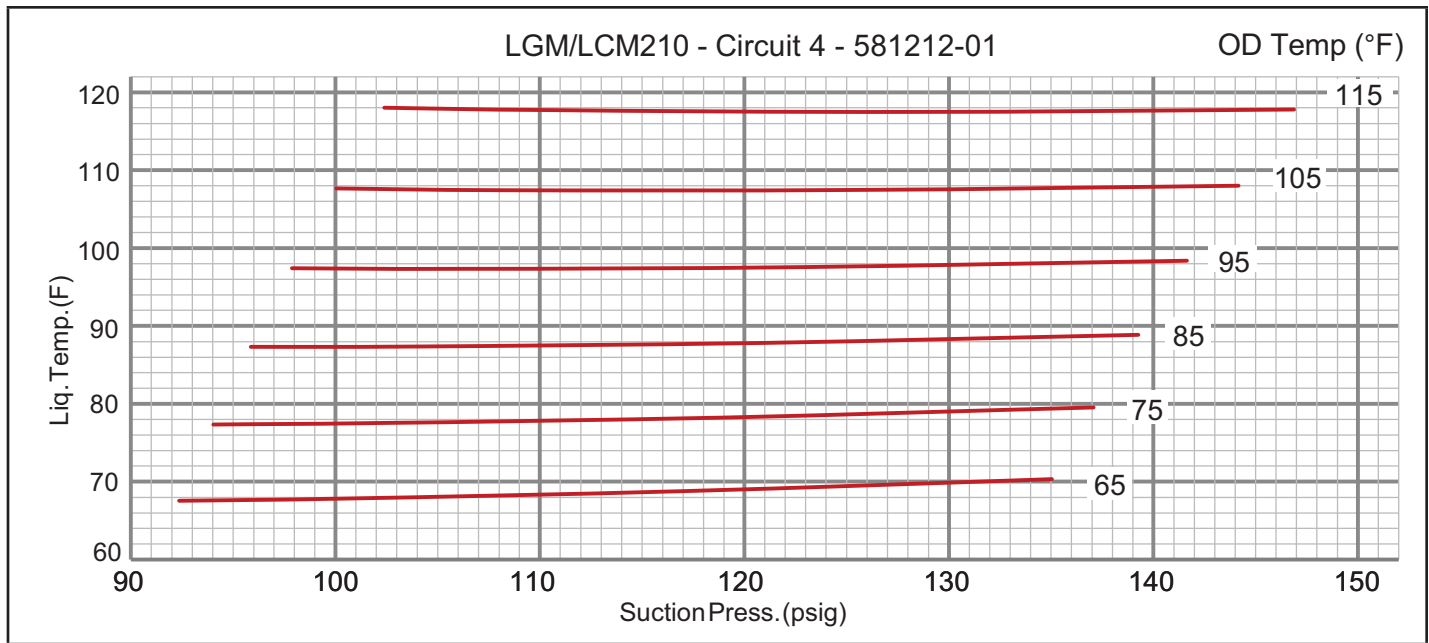
**LGT/LCT210 All-Aluminum OD Coil, No Reheat, Normal Operating Pressures- 581211-01**

	Outdoor Coil Entering Air Temperature											
	65°F		75°F		85°F		95°F		105°F		115°F	
	Suct (psig)	Disc (psig)	Suct (psig)	Disc (psig)	Suct (psig)	Disc (psig)	Suct (psig)	Disc (psig)	Suct (psig)	Disc (psig)	Suct (psig)	Disc (psig)
Circuit 1	110	219	111	258	113	304	114	355	116	412	118	476
	118	218	120	255	121	299	123	349	125	405	127	467
	135	221	137	256	139	296	142	344	144	397	146	456
	153	232	156	264	159	302	162	346	164	397	167	453
Circuit 2	111	216	113	253	114	292	116	334	117	377	118	421
	119	218	121	256	123	296	125	337	126	380	128	426
	135	223	138	262	140	302	143	344	145	388	148	433
	151	228	154	267	158	307	161	350	165	394	168	441
Circuit 3	92	219	93	257	95	308	97	370	99	444	102	530
	99	221	101	258	103	306	105	366	107	437	110	520
	116	228	118	260	120	303	122	358	125	425	128	503
	135	237	137	264	139	302	142	352	145	414	148	488
Circuit 4	92	222	94	257	96	304	98	364	100	435	102	519
	100	224	102	258	104	304	106	362	108	432	111	514
	117	231	119	261	121	304	123	359	126	427	128	506
	135	239	137	267	139	307	142	359	144	423	147	500





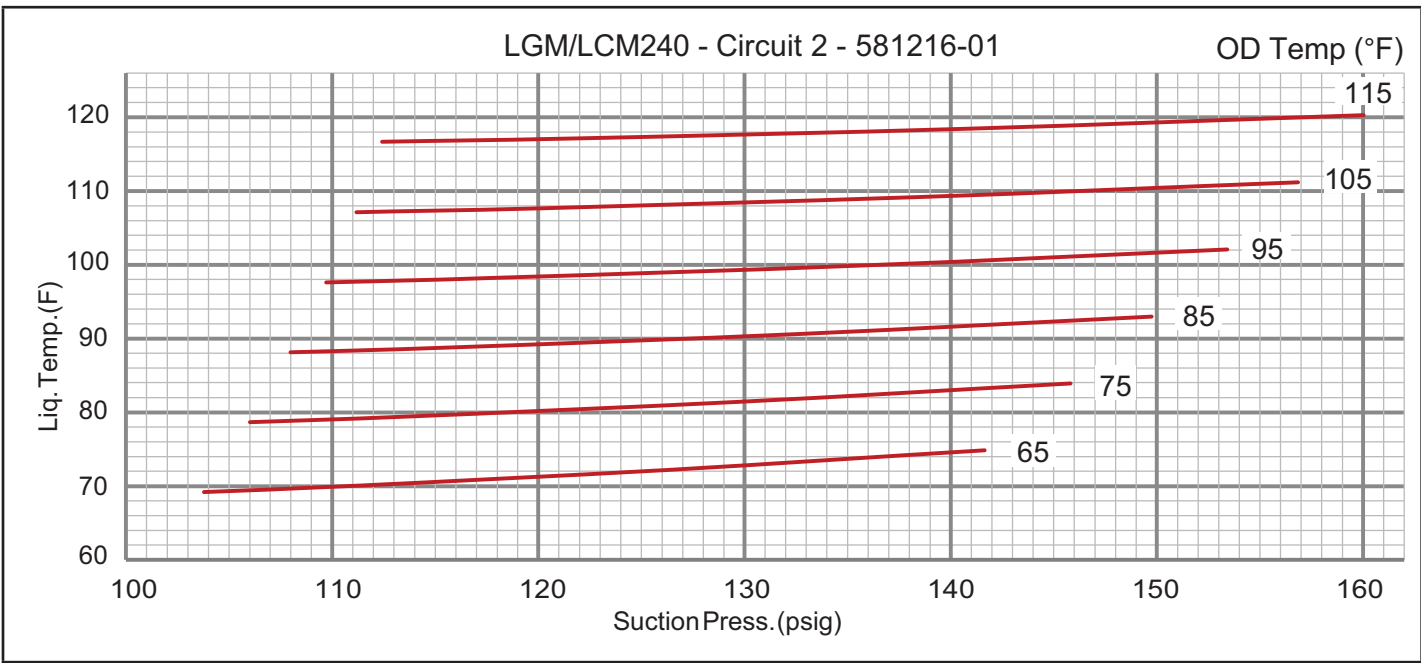
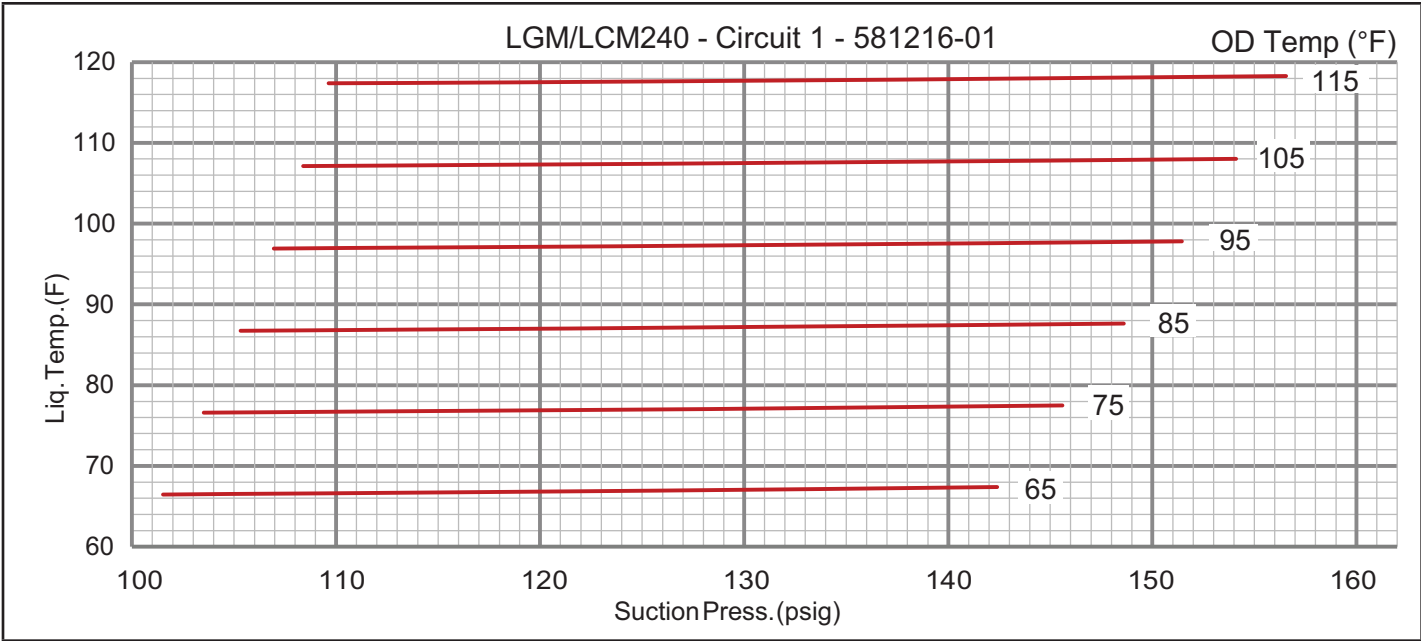


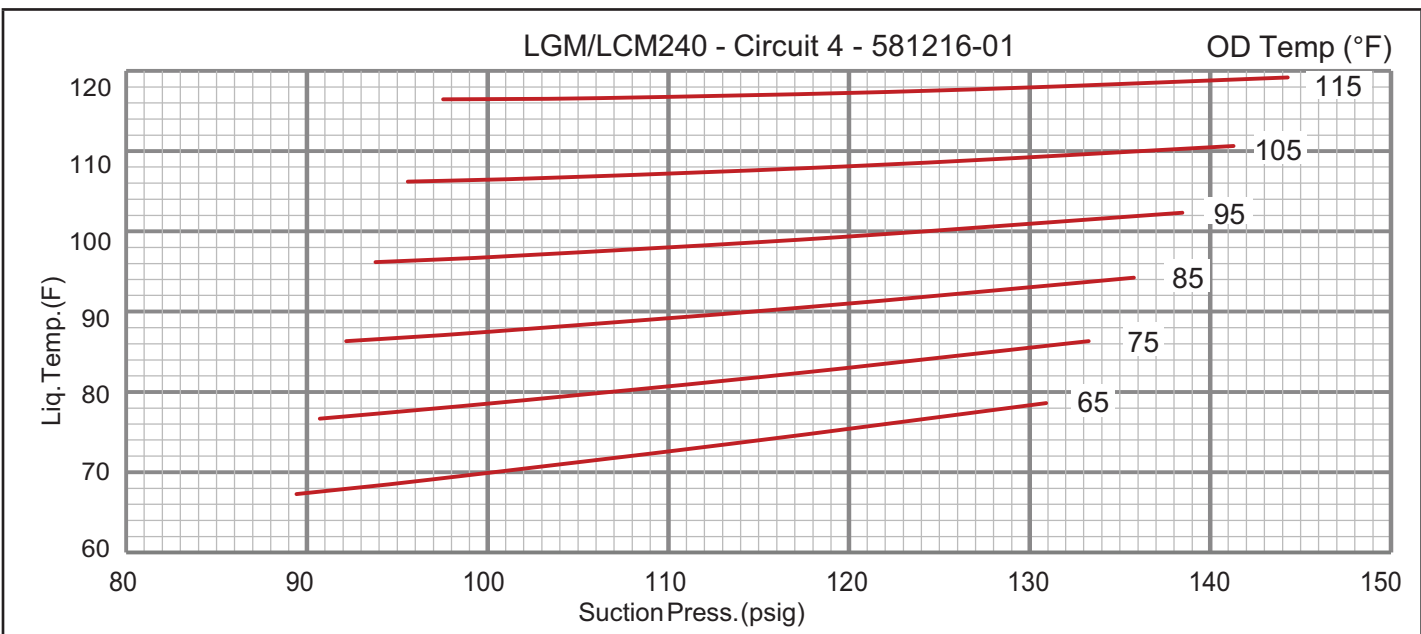
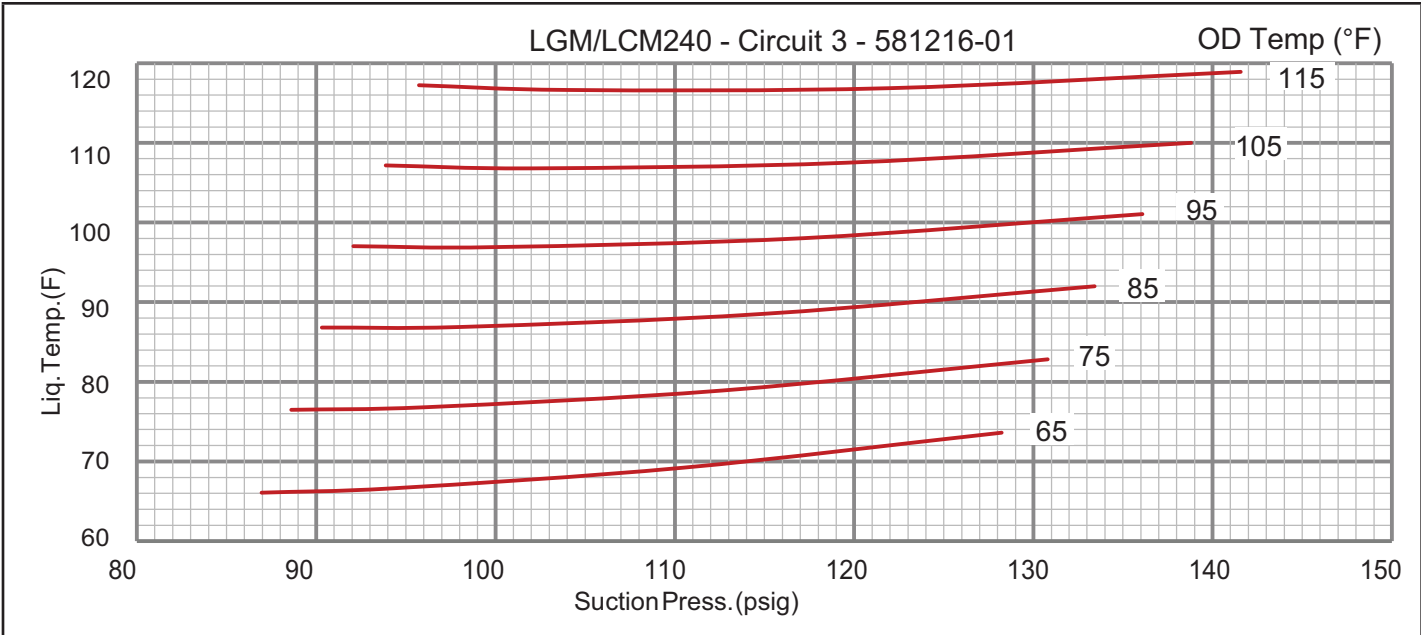


**TABLE 9**

**LGM/LCM240 All-Aluminum OD Coil, No Reheat, Normal Operating Pressures- 581215-01**

	Outdoor Coil Entering Air Temperature											
	65°F		75°F		85°F		95°F		105°F		115°F	
	Suct (psig)	Disc (psig)	Suct (psig)	Disc (psig)	Suct (psig)	Disc (psig)	Suct (psig)	Disc (psig)	Suct (psig)	Disc (psig)	Suct (psig)	Disc (psig)
Circuit 1	102	227	104	264	105	306	107	355	108	410	110	471
	109	228	112	264	114	306	116	354	117	409	119	469
	126	233	128	268	131	310	133	357	135	410	137	469
	142	244	146	278	149	318	151	364	154	416	157	475
Circuit 2	104	225	106	260	108	301	110	346	111	396	112	451
	111	227	114	263	116	304	118	349	120	400	122	455
	126	233	130	269	133	310	136	356	138	407	141	462
	142	239	146	275	150	317	153	363	157	414	160	470
Circuit 3	87	216	89	252	90	293	92	338	94	387	96	441
	94	218	96	254	98	295	100	340	102	389	104	444
	110	222	113	258	115	299	117	345	120	395	122	450
	128	228	131	264	133	306	136	352	139	402	142	457
Circuit 4	89	220	91	256	92	298	94	344	96	396	98	453
	97	221	99	258	100	300	102	346	104	398	106	455
	113	226	115	262	117	305	120	352	122	404	125	461
	131	231	133	268	136	311	138	358	141	411	144	468

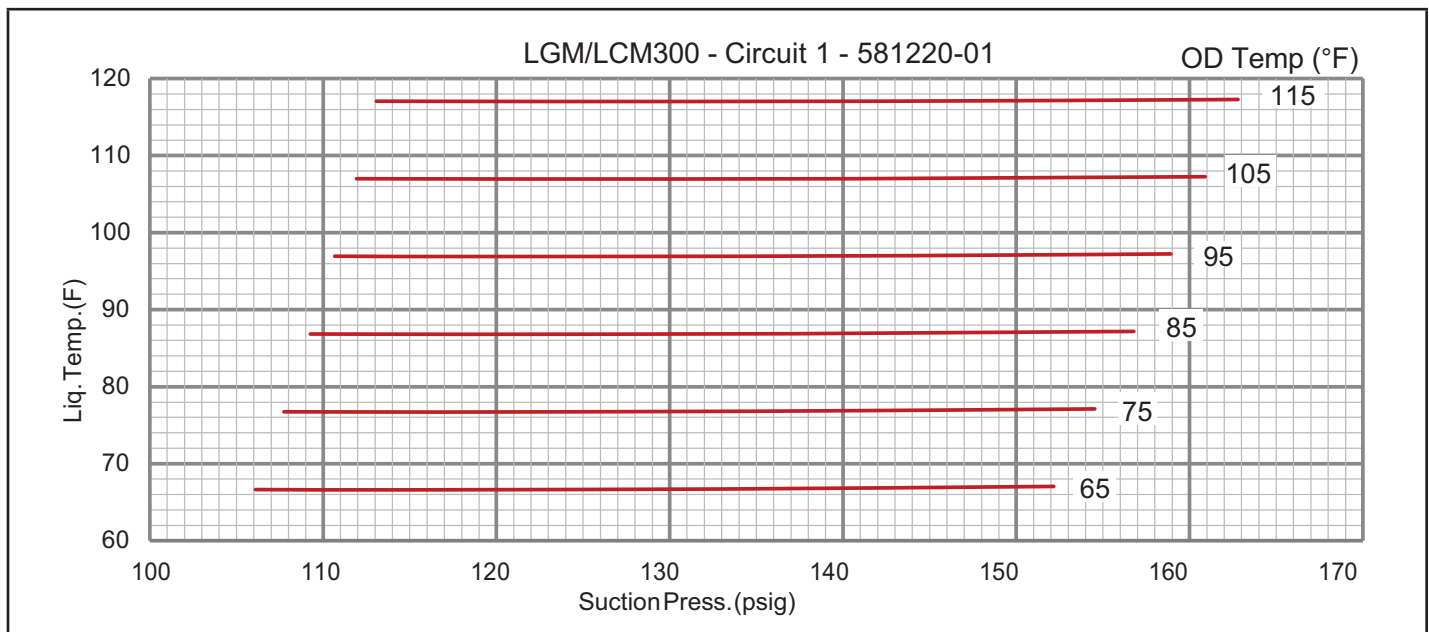




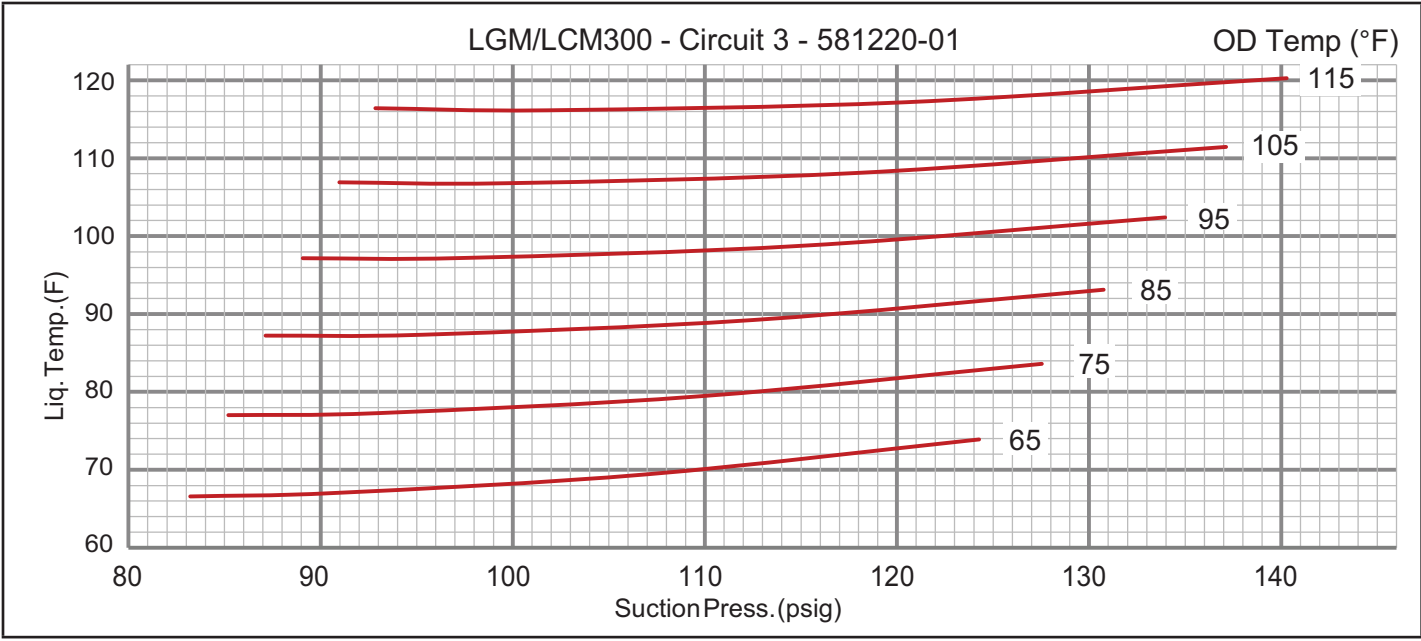
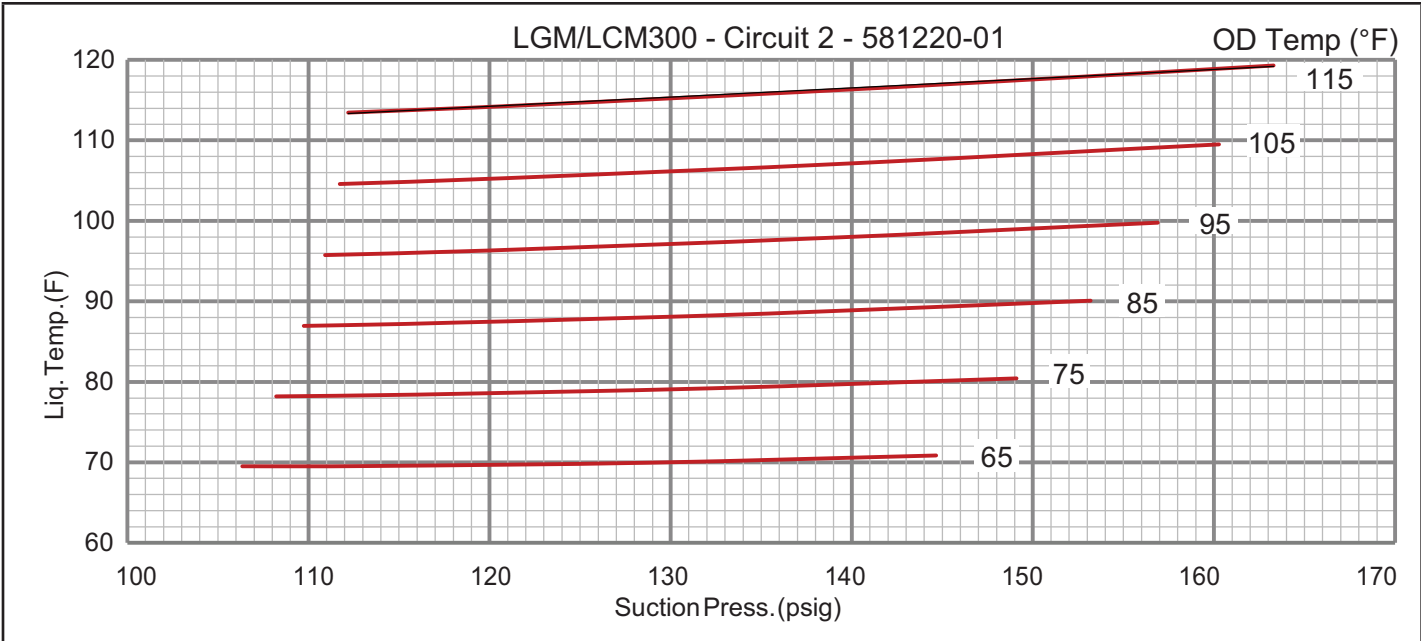
**TABLE 10**

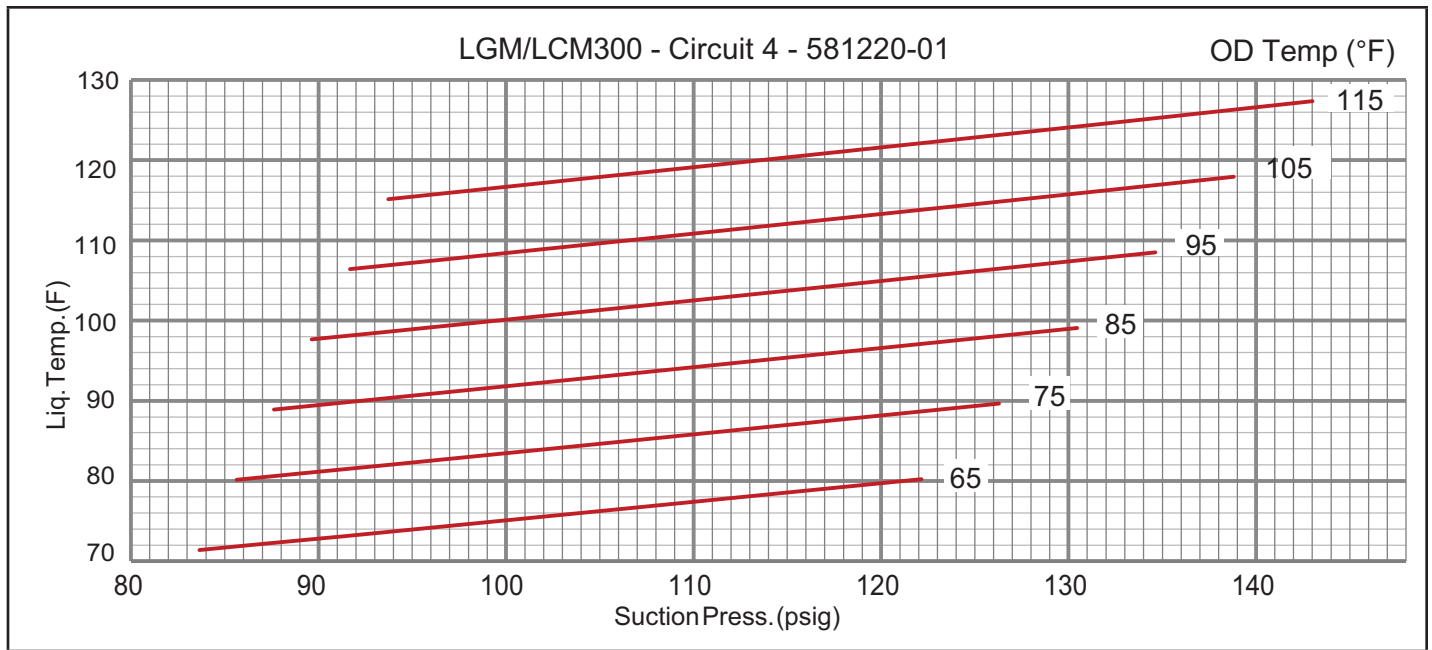
**LGM/LCM300 All-Aluminum OD Coil, No Reheat, Normal Operating Pressures- 581219-01**

	Outdoor Coil Entering Air Temperature											
	65°F		75°F		85°F		95°F		105°F		115°F	
	Suct (psig)	Disc (psig)	Suct (psig)	Disc (psig)	Suct (psig)	Disc (psig)	Suct (psig)	Disc (psig)	Suct (psig)	Disc (psig)	Suct (psig)	Disc (psig)
Circuit 1	106	230	108	274	109	327	111	390	112	462	113	544
	115	228	117	269	118	319	120	379	121	448	123	527
	133	233	135	267	137	312	139	366	141	429	142	502
	152	248	155	277	157	316	159	364	161	421	163	488
Circuit 2	106	236	108	276	110	319	111	367	112	418	112	474
	114	242	116	281	118	324	120	371	121	423	122	478
	129	251	132	290	135	333	138	383	140	431	142	486
	145	259	149	298	153	341	157	387	160	438	163	493
Circuit 3	83	228	85	271	87	317	89	367	91	422	93	480
	91	232	93	274	95	320	98	370	100	424	102	482
	107	240	110	281	112	326	115	372	118	428	120	485
	124	249	128	289	131	333	134	381	137	433	140	489
Circuit 4	84	234	86	276	88	321	90	370	92	422	94	477
	91	237	94	279	96	324	99	373	101	425	104	480
	107	243	110	285	113	331	116	378	120	432	123	488
	122	251	126	294	130	340	135	389	139	441	143	497





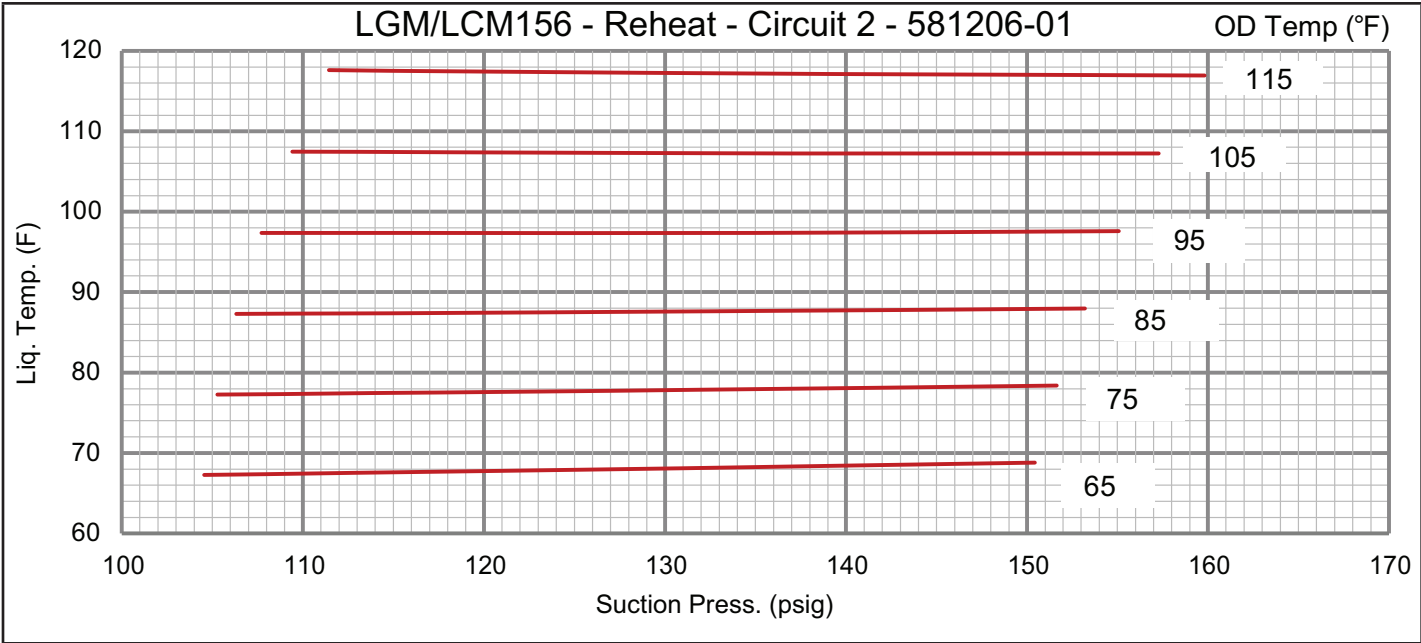
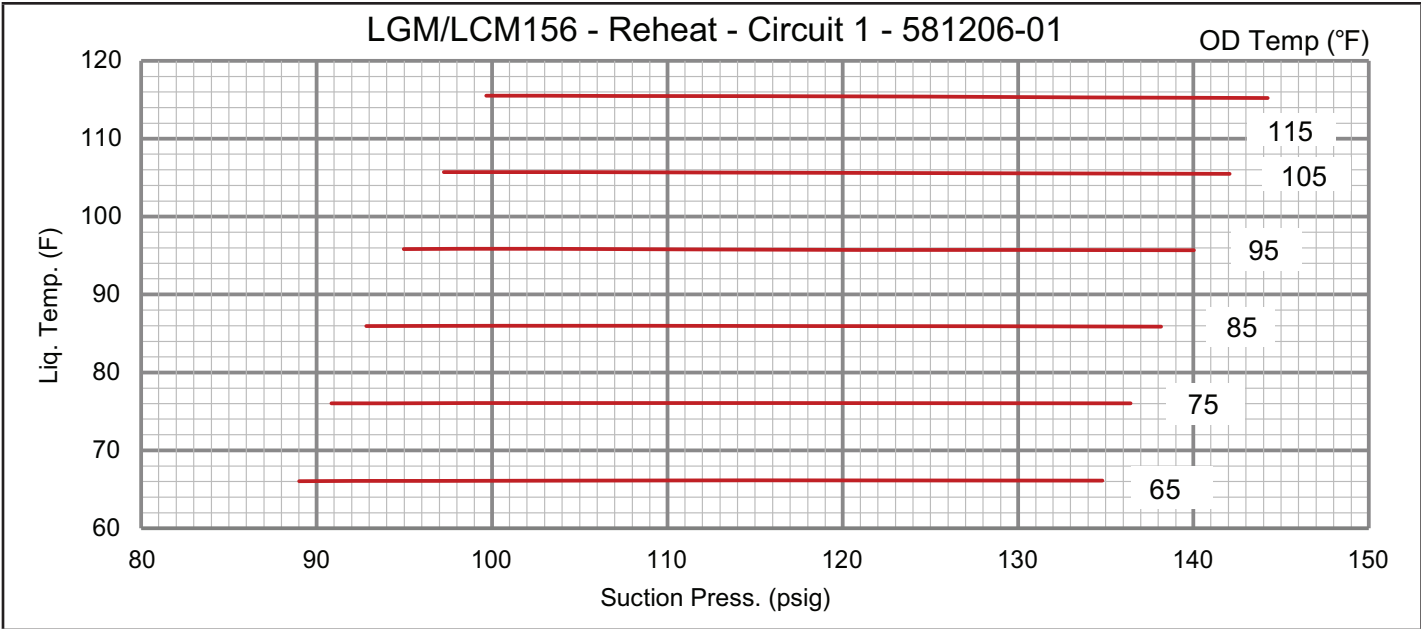




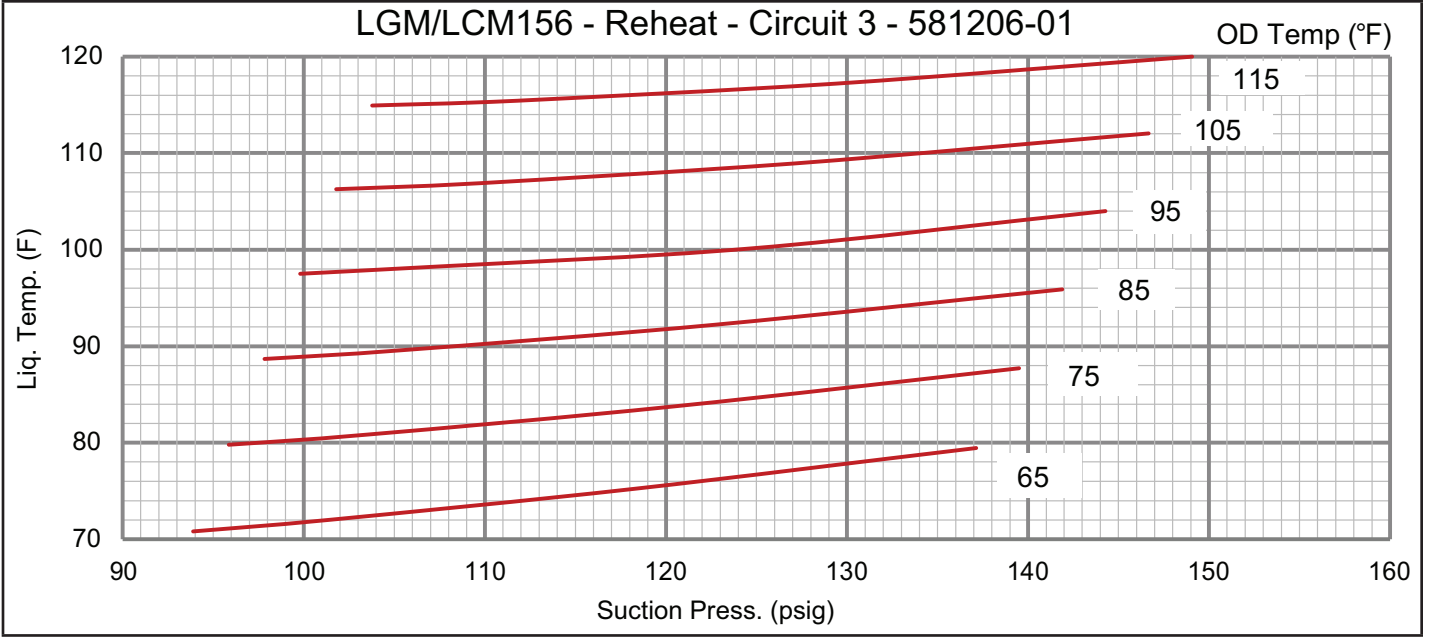
**TABLE 11**

**LGM/LCM156 All-Aluminum OD Coil, Reheat, Normal Operating Pressures- 581205-01**

	Outdoor Coil Entering Air Temperature											
	65°F		75°F		85°F		95°F		105°F		115°F	
	Suct (psig)	Disc (psig)	Suct (psig)	Disc (psig)	Suct (psig)	Disc (psig)	Suct (psig)	Disc (psig)	Suct (psig)	Disc (psig)	Suct (psig)	Disc (psig)
Circuit 1	89	215	91	249	93	290	95	338	97	392	100	452
	97	214	99	247	101	286	103	333	105	386	107	445
	115	215	116	246	118	284	121	331	122	378	125	435
	135	223	136	252	138	287	140	329	142	377	144	432
Circuit 2	105	220	105	257	106	299	108	346	109	398	111	455
	113	222	114	259	115	301	116	348	118	399	120	456
	131	228	132	265	133	306	135	354	137	403	139	459
	150	235	152	271	153	312	155	357	157	408	160	463
Circuit 3	94	218	96	253	98	293	100	336	102	384	104	437
	101	221	104	256	106	296	108	340	110	388	112	440
	118	226	120	262	123	301	125	345	127	393	129	446
	137	231	140	266	142	306	144	350	147	398	149	451



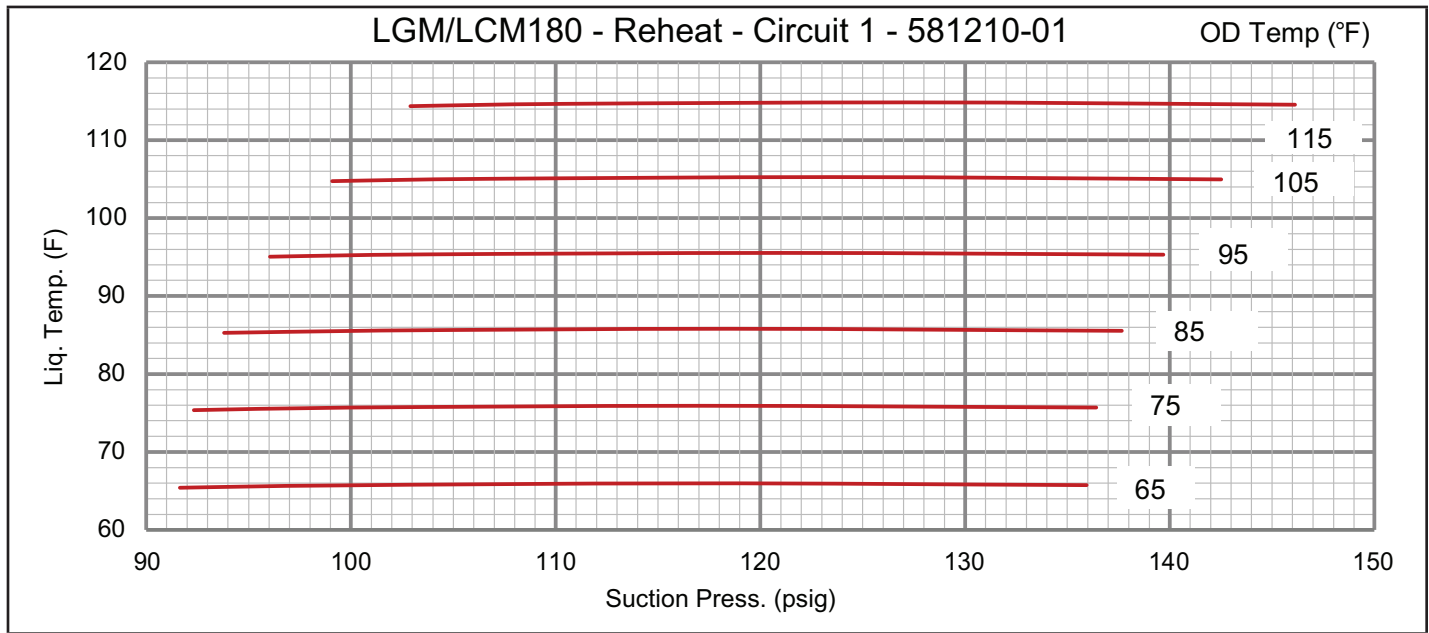
# LGM/LCM156 - Reheat - Circuit 3 - 581206-01



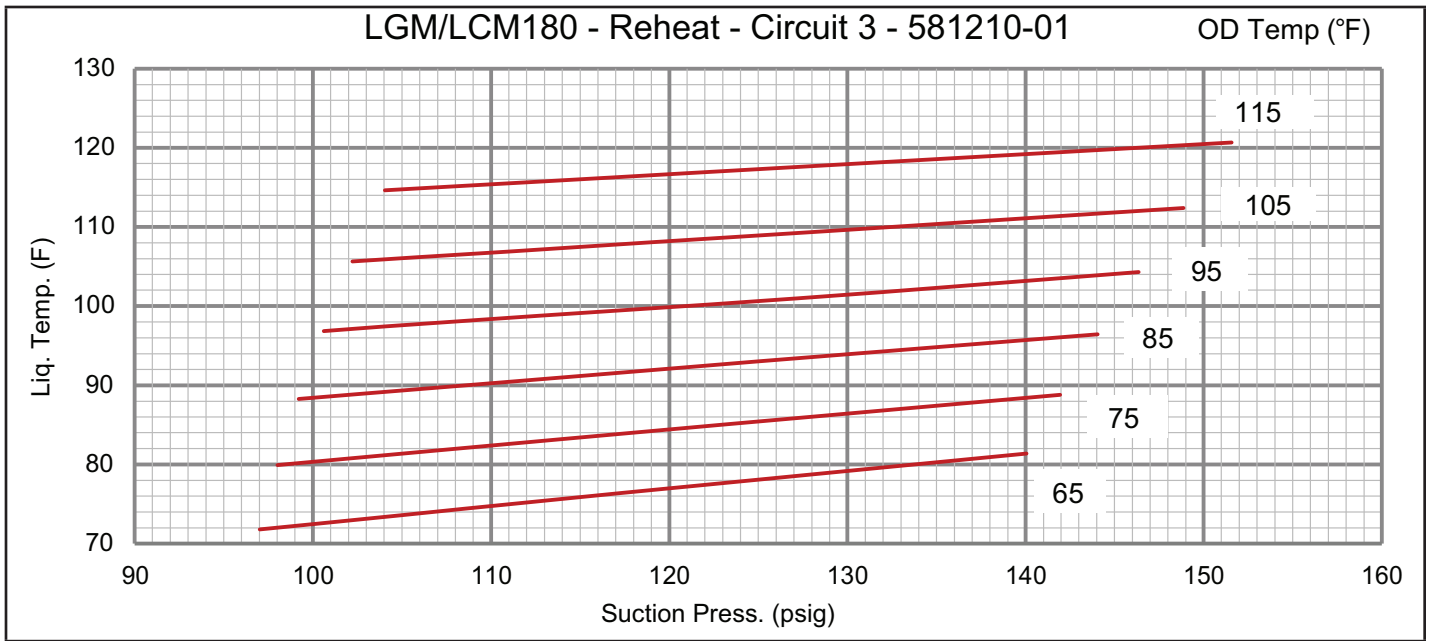
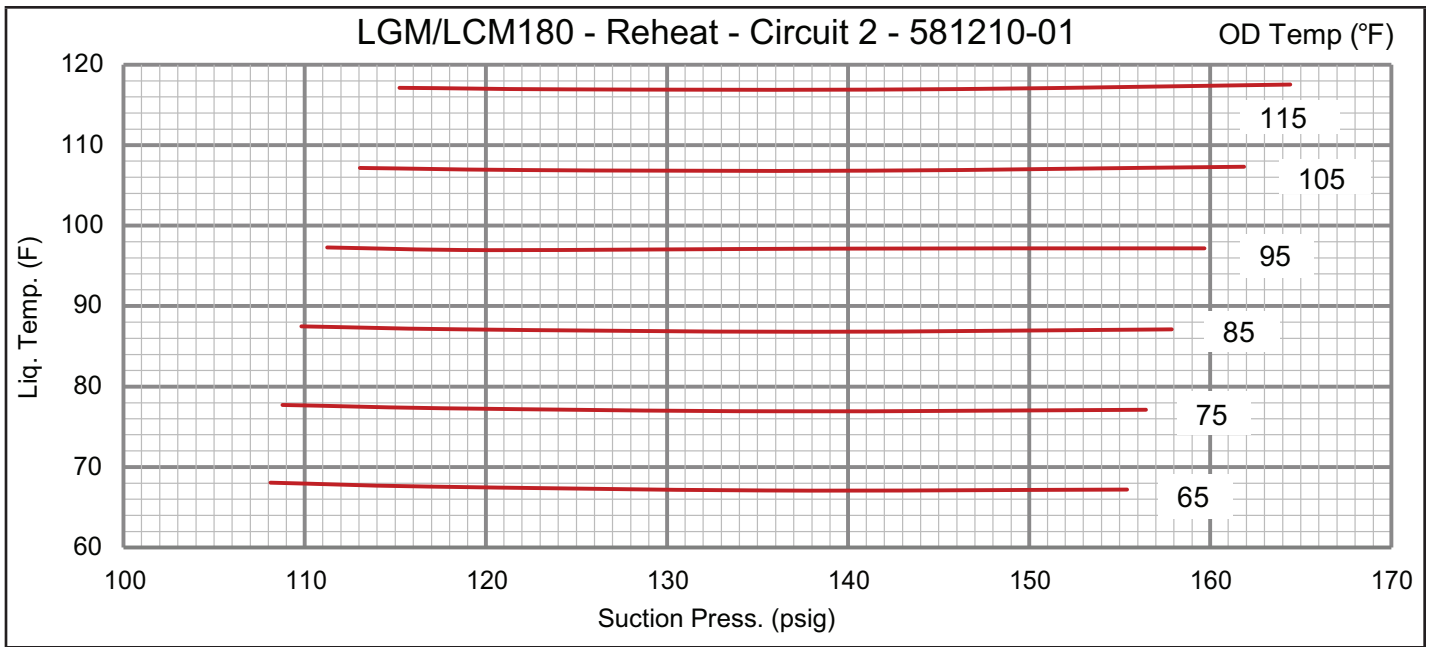
**TABLE 12**

**LGM/LCM180 All-Aluminum OD Coil, Reheat, Normal Operating Pressures- 581209-01**

	Outdoor Coil Entering Air Temperature											
	65°F		75°F		85°F		95°F		105°F		115°F	
	Suct (psig)	Disc (psig)	Suct (psig)	Disc (psig)	Suct (psig)	Disc (psig)	Suct (psig)	Disc (psig)	Suct (psig)	Disc (psig)	Suct (psig)	Disc (psig)
Circuit 1	92	215	92	264	94	321	96	385	99	457	103	537
	99	220	100	264	101	317	104	377	107	445	110	521
	117	230	117	267	118	312	121	363	124	424	127	492
	136	243	136	272	138	308	140	353	143	405	146	465
Circuit 2	108	212	109	253	110	300	111	353	113	412	115	478
	117	218	118	257	119	302	120	354	122	411	124	475
	135	230	136	266	138	308	139	357	141	410	144	471
	155	244	156	277	158	315	160	360	162	410	164	467
Circuit 3	97	228	98	264	99	304	101	350	102	400	104	455
	105	231	106	267	108	308	109	354	111	404	113	459
	122	237	123	274	125	315	127	361	129	412	132	467
	140	244	142	281	144	322	146	369	149	420	152	476



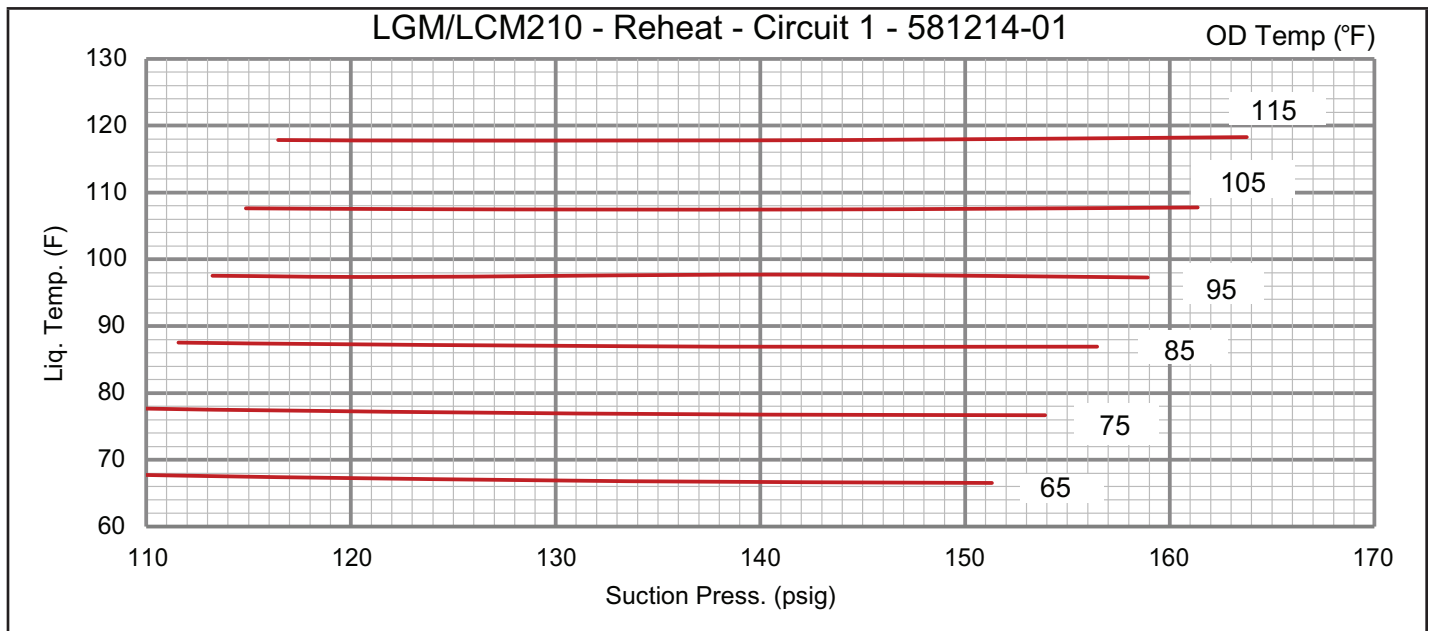


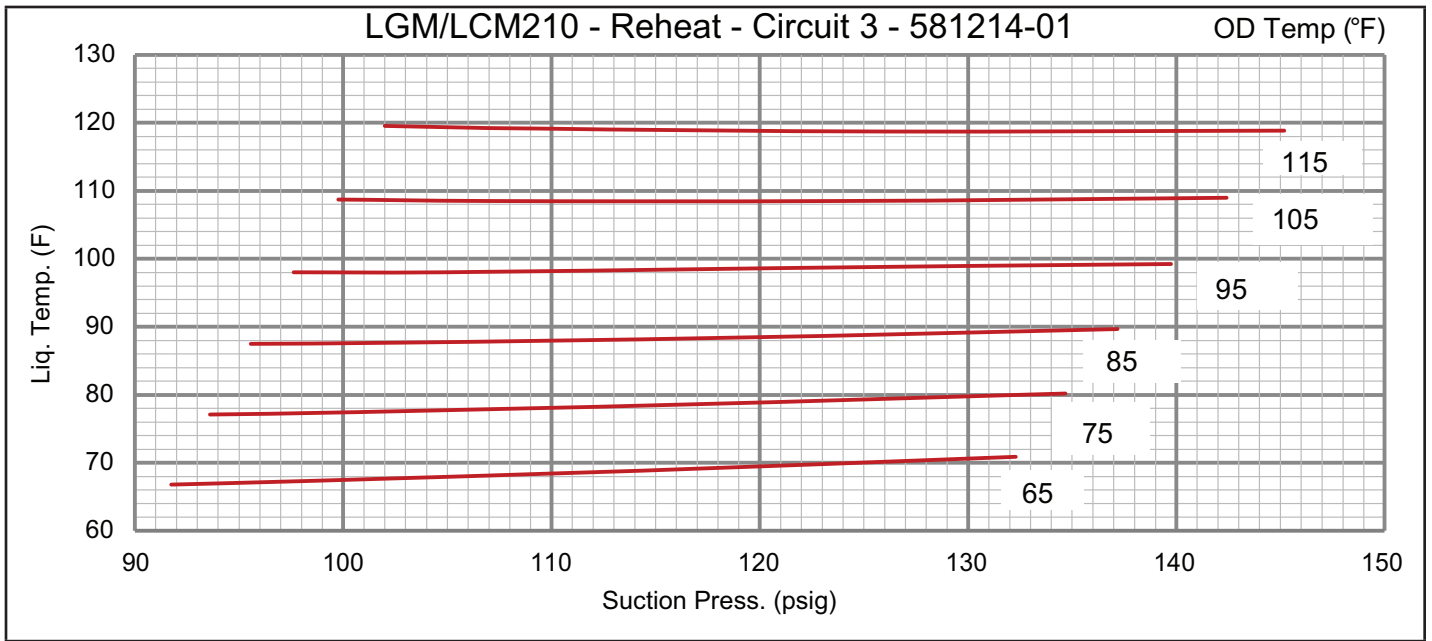
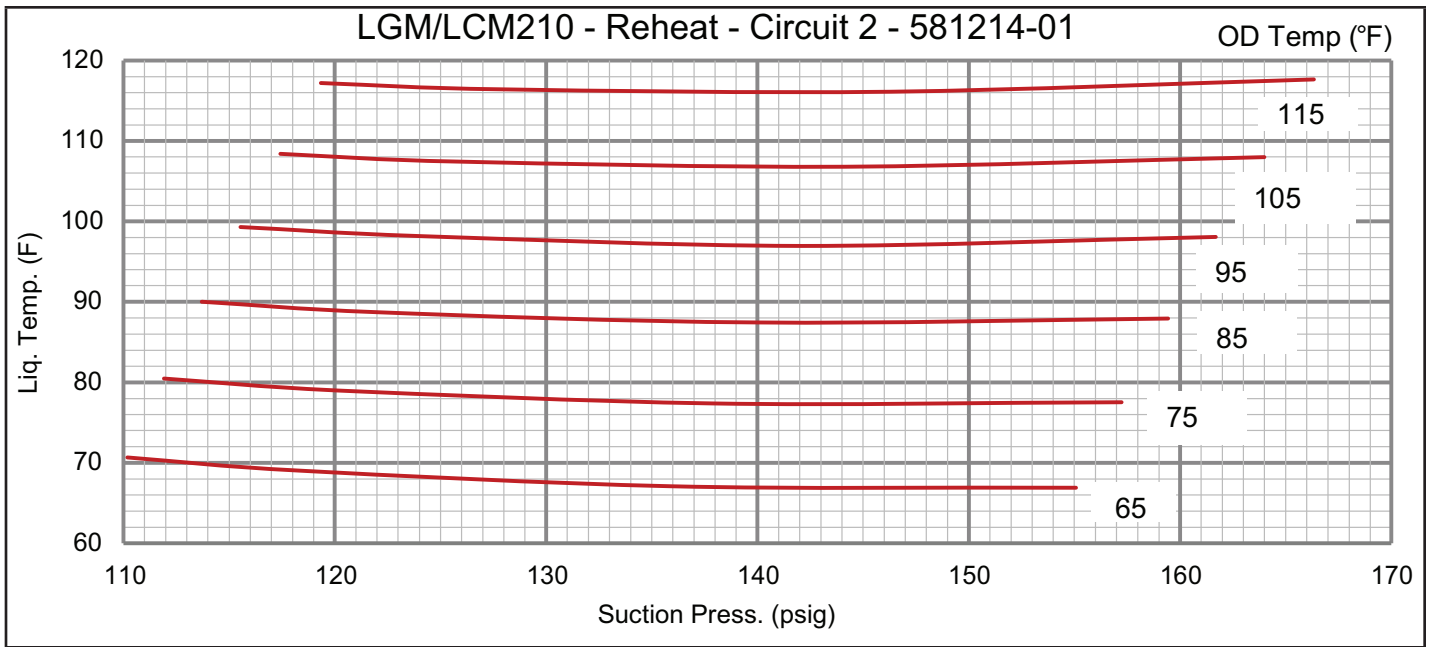


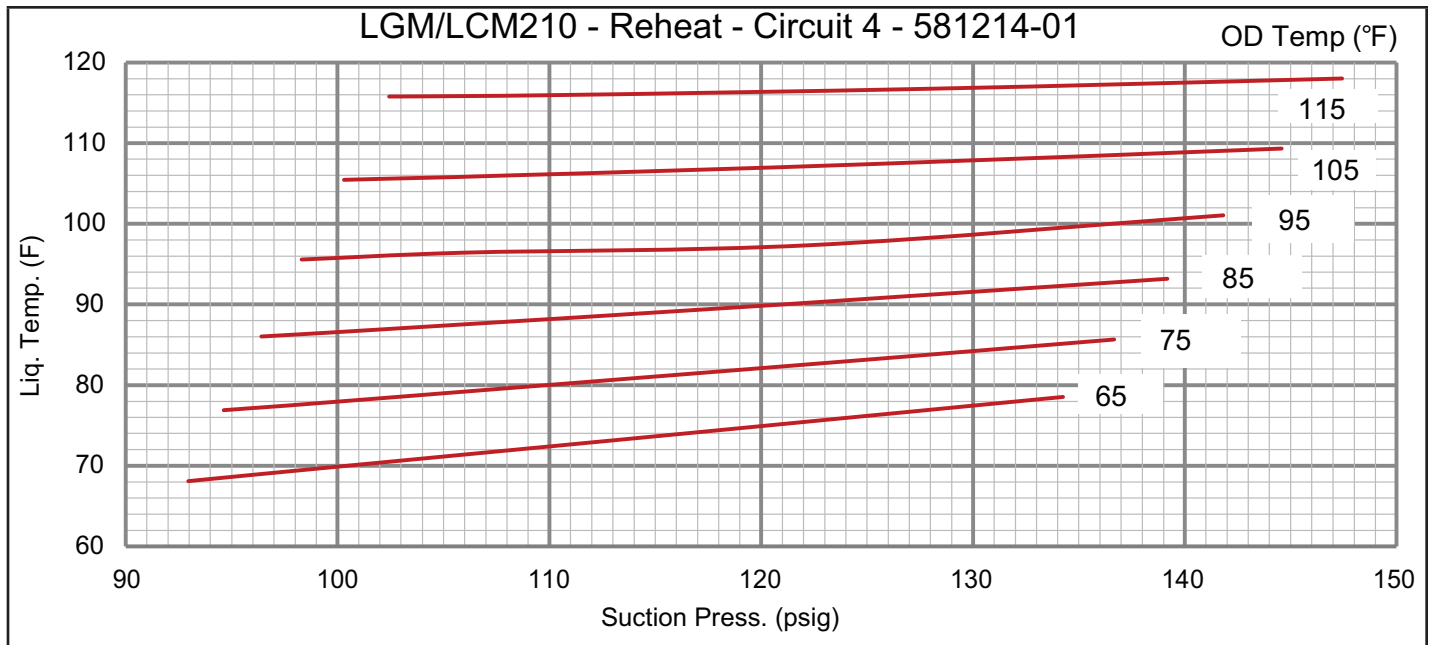
**TABLE 13**

**LGM/LCM210 All-Aluminum OD Coil, Reheat, Normal Operating Pressures- 581213-01**

	Outdoor Coil Entering Air Temperature											
	65°F		75°F		85°F		95°F		105°F		115°F	
	Suct (psig)	Disc (psig)	Suct (psig)	Disc (psig)	Suct (psig)	Disc (psig)	Suct (psig)	Disc (psig)	Suct (psig)	Disc (psig)	Suct (psig)	Disc (psig)
Circuit 1	108	207	110	242	112	281	113	325	115	373	116	426
	116	211	118	246	120	285	122	329	124	377	126	430
	134	218	136	253	138	292	141	336	142	385	144	438
	151	225	154	260	156	299	159	343	161	391	164	444
Circuit 2	110	221	112	243	114	277	116	322	117	379	119	447
	118	227	120	253	122	290	124	338	126	399	128	471
	136	235	138	268	140	312	142	368	144	435	146	514
	155	238	157	278	159	329	162	392	164	467	166	553
Circuit 3	92	213	94	248	96	289	98	334	100	383	102	438
	99	216	101	251	103	292	105	337	107	387	109	442
	114	222	116	257	119	297	121	345	124	393	126	448
	132	226	135	262	137	302	140	348	142	398	145	454
Circuit 4	93	216	95	252	96	293	98	338	100	389	102	443
	100	220	102	256	104	297	106	342	108	393	111	448
	116	225	118	262	121	303	122	351	125	400	128	455
	134	229	137	267	139	308	142	355	145	406	147	462



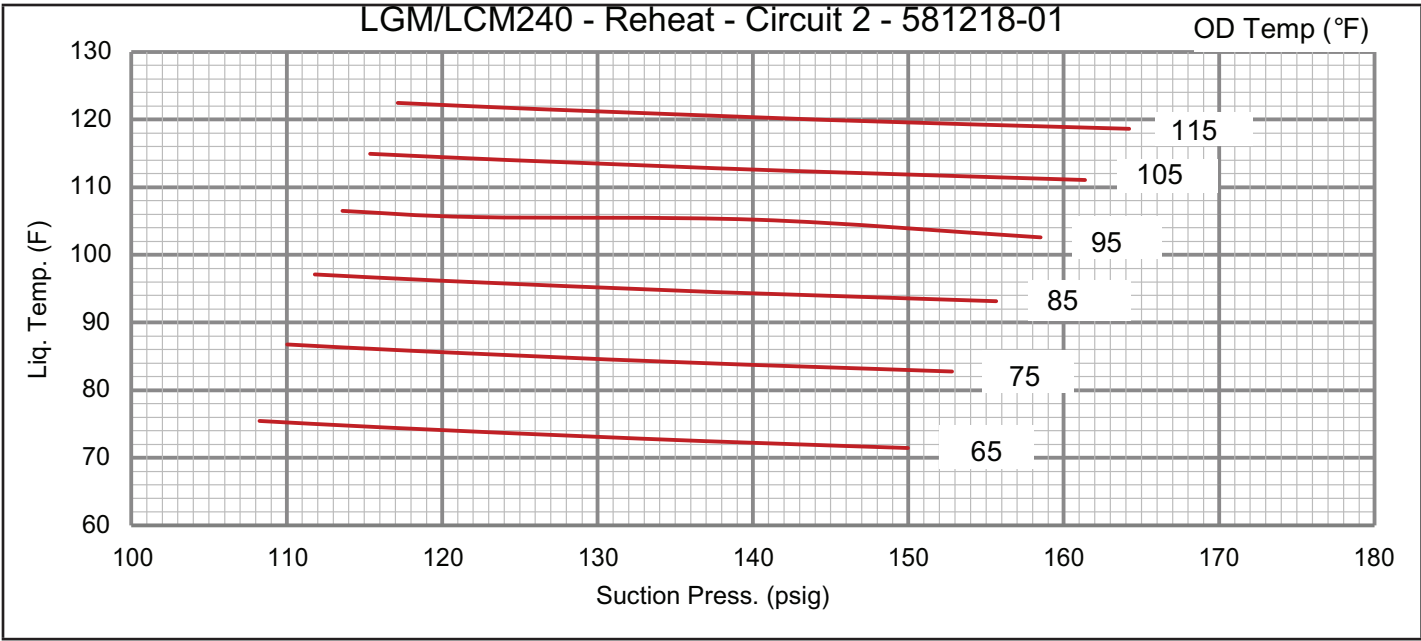
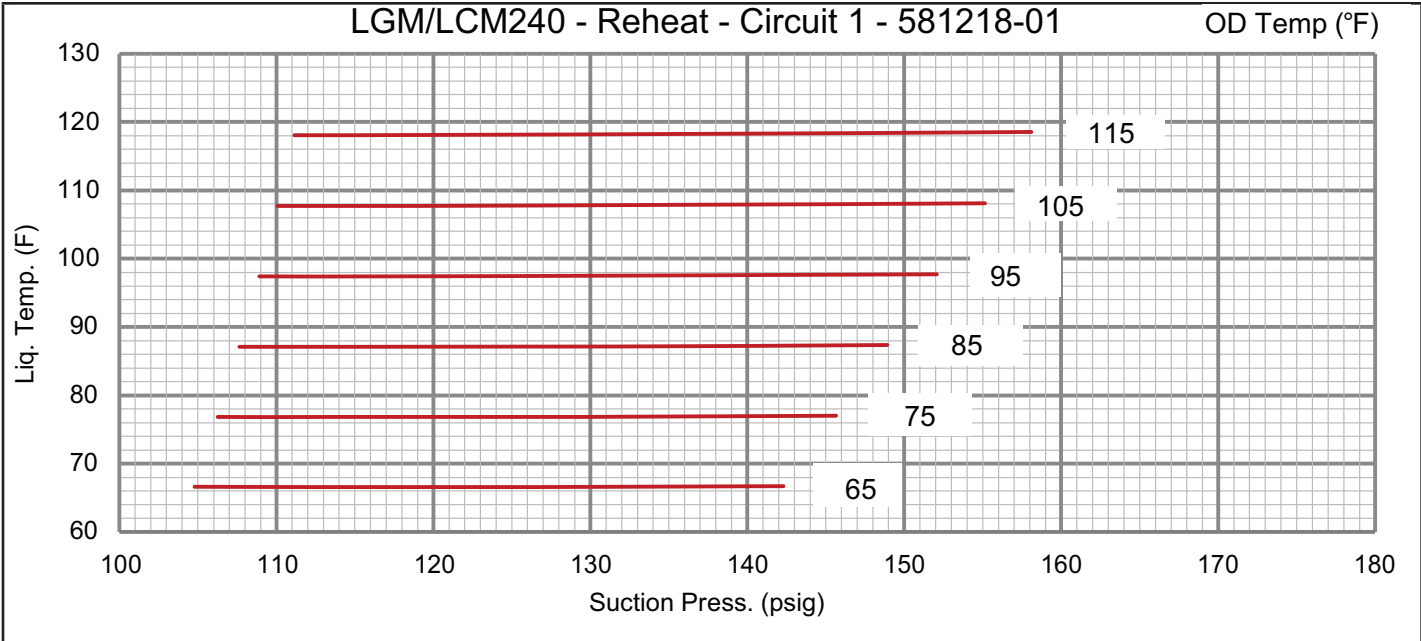


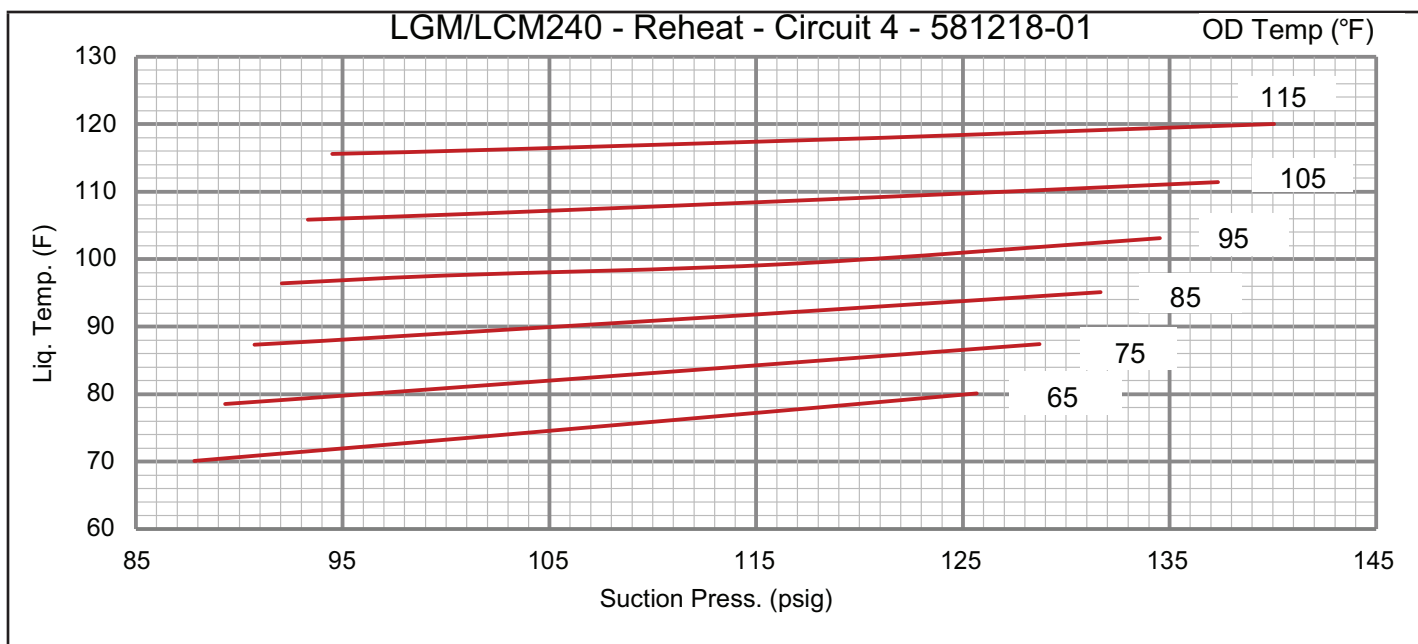
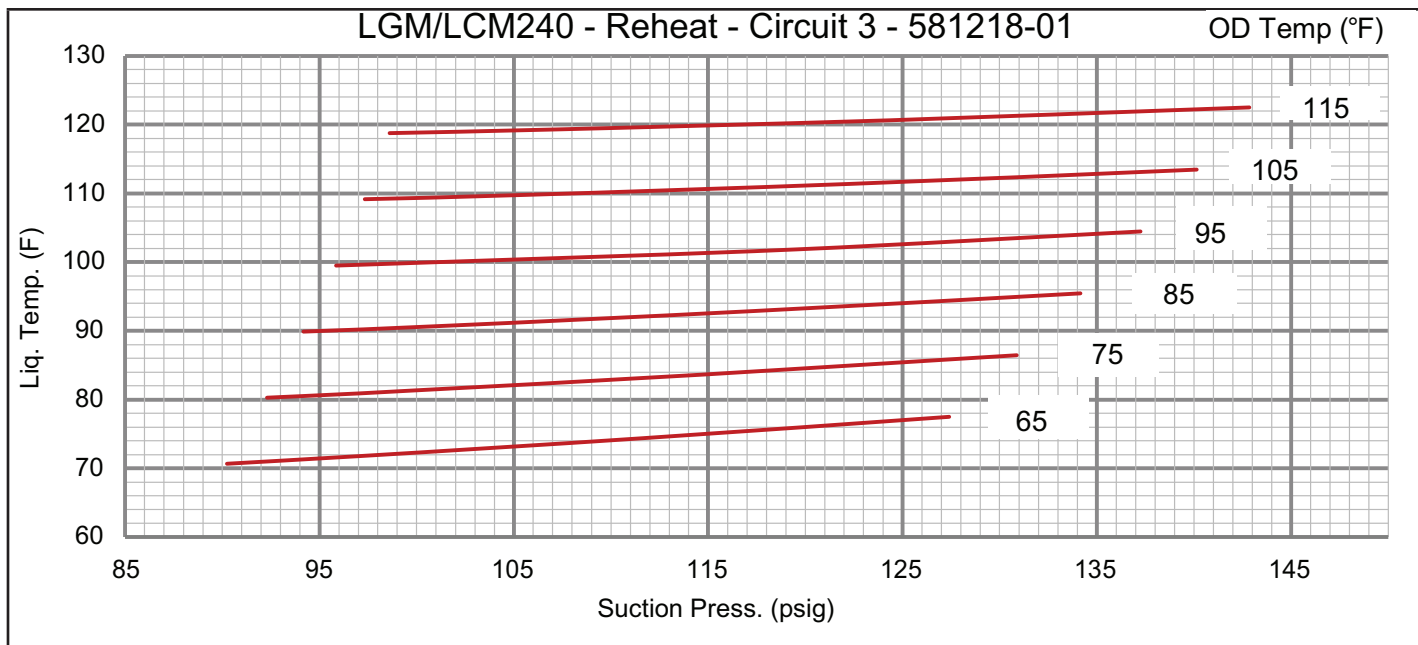


**TABLE 14**

**LGM/LCM240 All-Aluminum OD Coil, Reheat, Normal Operating Pressures- 581217-01**

	Outdoor Coil Entering Air Temperature											
	65°F		75°F		85°F		95°F		105°F		115°F	
	Suct (psig)	Disc (psig)	Suct (psig)	Disc (psig)	Suct (psig)	Disc (psig)	Suct (psig)	Disc (psig)	Suct (psig)	Disc (psig)	Suct (psig)	Disc (psig)
Circuit 1	105	223	106	259	108	300	109	348	110	401	111	461
	112	227	114	262	116	303	117	350	119	403	120	463
	127	234	129	269	132	310	134	357	137	409	139	468
	142	243	146	278	149	318	152	364	155	417	158	475
Circuit 2	108	227	110	258	112	295	114	338	115	387	117	442
	116	231	118	262	120	300	122	344	124	394	126	451
	133	239	135	273	138	313	140	359	142	411	145	469
	150	250	153	285	156	327	159	375	161	430	164	490
Circuit 3	90	216	92	252	94	292	96	336	97	385	99	438
	97	219	100	255	102	295	104	339	105	388	107	441
	112	224	115	260	117	300	120	345	122	395	124	449
	127	229	131	265	134	306	137	352	140	401	143	456
Circuit 4	88	221	89	257	91	298	92	343	93	393	95	448
	95	223	97	260	98	301	100	347	102	397	103	452
	110	229	112	266	115	308	117	353	119	404	121	459
	126	234	129	272	132	314	135	360	137	411	140	467



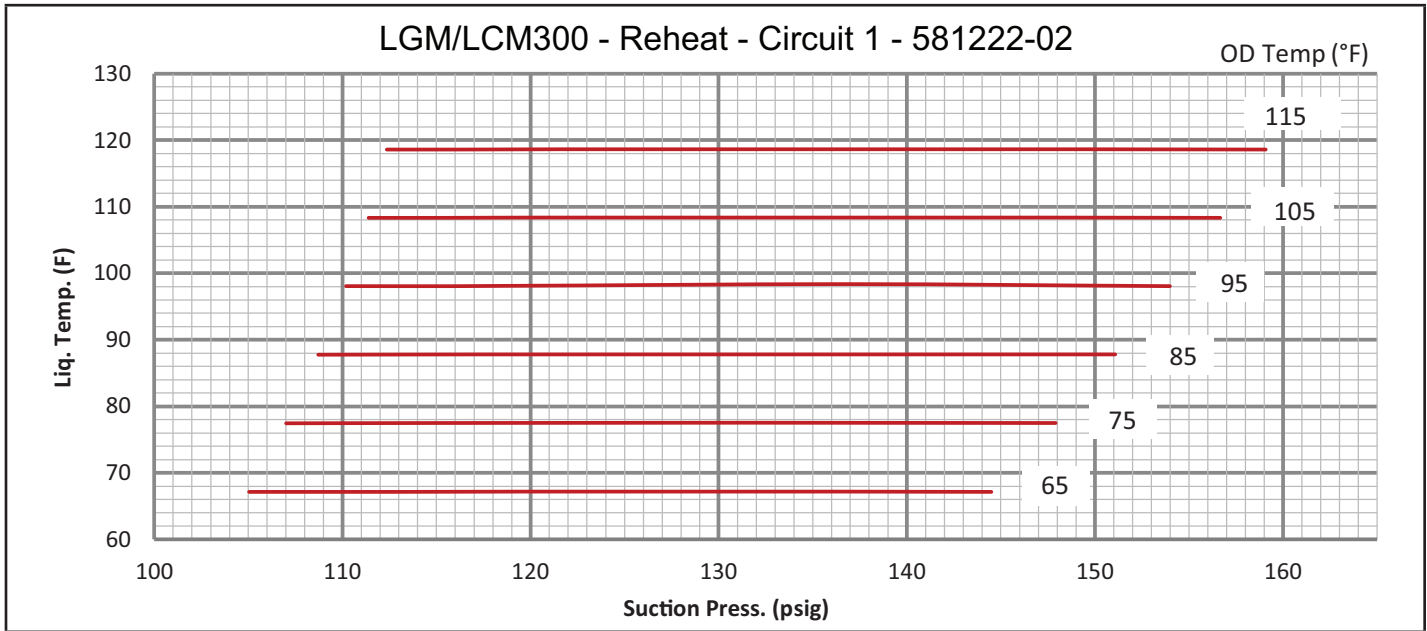


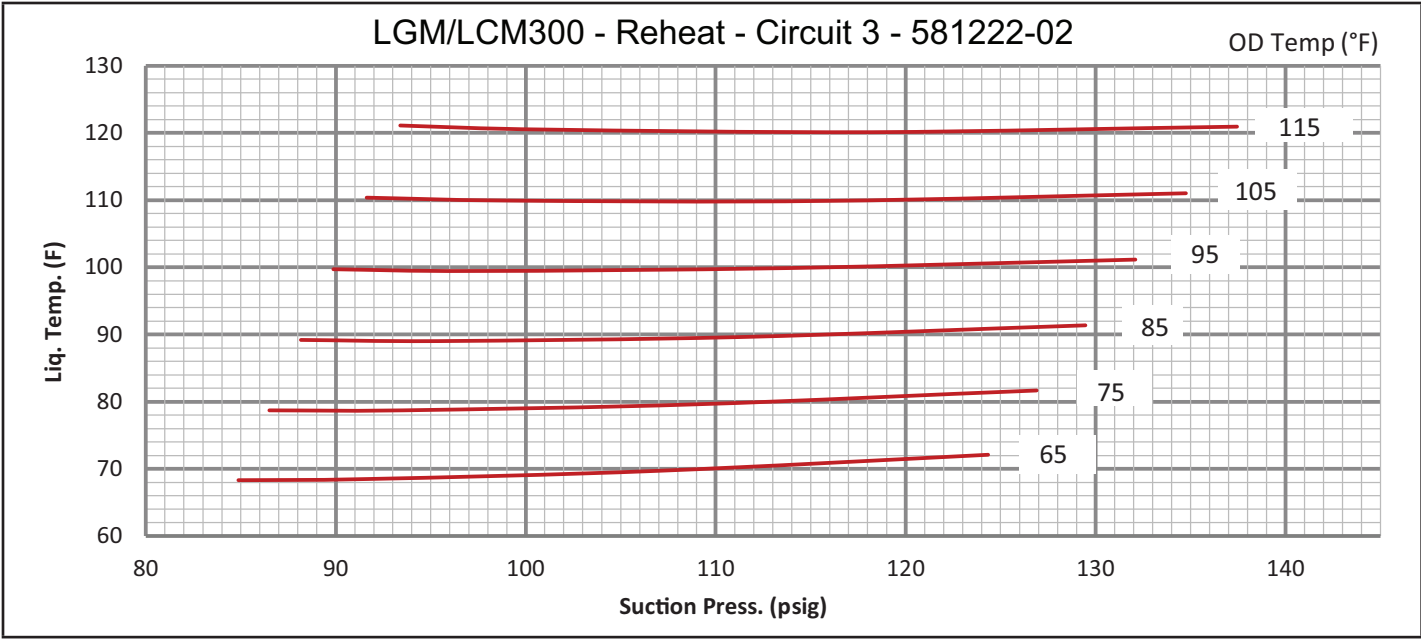
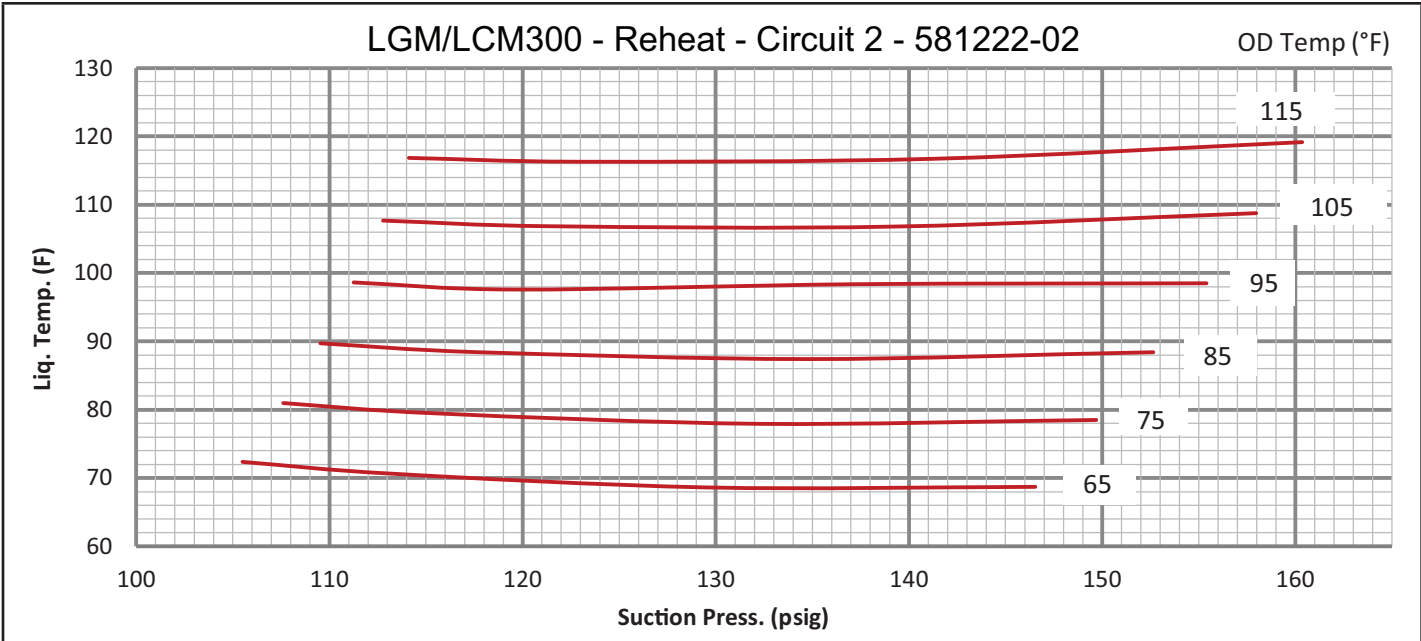


**TABLE 15**

**LGM/LCM300 All-Aluminum OD Coil, Reheat, Normal Operating Pressures- 581221-02**

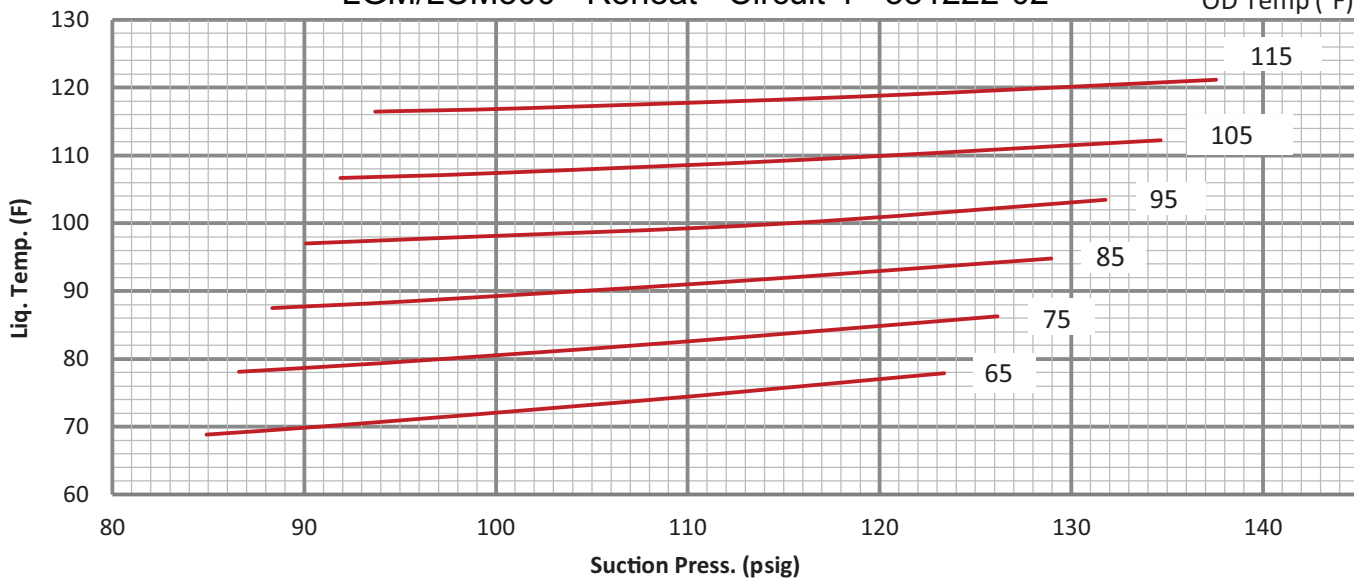
	Outdoor Coil Entering Air Temperature											
	65°F		75°F		85°F		95°F		105°F		115°F	
	Suct (psig)	Disc (psig)	Suct (psig)	Disc (psig)	Suct (psig)	Disc (psig)	Suct (psig)	Disc (psig)	Suct (psig)	Disc (psig)	Suct (psig)	Disc (psig)
Circuit 1	105	219	107	252	109	291	110	336	111	386	112	442
	113	222	115	255	117	295	119	340	120	390	122	447
	128	229	131	264	134	304	137	347	138	401	140	459
	145	240	148	276	151	317	154	363	157	416	159	474
Circuit 2	106	237	108	270	110	309	111	356	113	411	114	473
	113	245	116	278	118	319	120	368	121	424	123	488
	130	258	132	294	135	338	137	383	139	448	141	514
	147	267	150	306	153	353	155	407	158	469	160	538
Circuit 3	85	239	87	280	88	332	90	395	92	468	93	552
	92	240	94	279	95	329	97	389	99	459	101	540
	107	249	109	283	111	327	114	388	116	447	118	523
	124	267	127	296	129	335	132	385	135	445	137	515
Circuit 4	85	240	87	280	88	328	90	381	92	442	94	509
	92	243	94	283	96	329	98	382	100	442	102	509
	107	253	109	291	112	336	115	391	116	445	119	510
	123	266	126	303	129	346	132	396	135	453	138	516





# LGM/LCM300 - Reheat - Circuit 4 - 581222-02

OD Temp (°F)



## F-Compressor Controls

See unit wiring diagram to determine which controls are used on each unit.

### 1 - High Pressure Switch (S4, S7, S28, S96)

The compressor circuit is protected by a high pressure switch which opens at 640 psig  $\pm$  10 psig (4413 kPa  $\pm$  70 kPa) and automatically resets at 475 psig  $\pm$  20 psig (3275kPa  $\pm$  138 kPa).

### 2 - Low Pressure Switch (S87, S88, S97, S98)

The compressor circuit is protected by a low pressure switch. Switch opens at 40 psig  $\pm$  5 psig (276  $\pm$  34 kPa) and automatically resets at 90 psig  $\pm$  5 psig (621 kPa  $\pm$  34 kPa).

### 3 - Crankcase Heater (HR1, HR2, HR5, HR11)

Units have compressors which contain a belly band compressor oil heater which must be on 24 hours before running compressors. Energize by setting thermostat so that there is no cooling demand, to prevent compressor from cycling, and apply power to unit.

### 4 - Condenser Fan Operation

#### 156, 180

Condenser fan 3 and 4 are energized when compressor 1 is the ONLY compressor energized. As cooling demand increases, all four condenser fans are energized. See FIGURE 28.

Condenser fans 1 and 3 are de-energized when outdoor temperature drops below 55°F (13°C).

Condenser fans 2 & 4 modulate to maintain target liquid temperatures when outdoor temperature drops below 55°F (13°C).

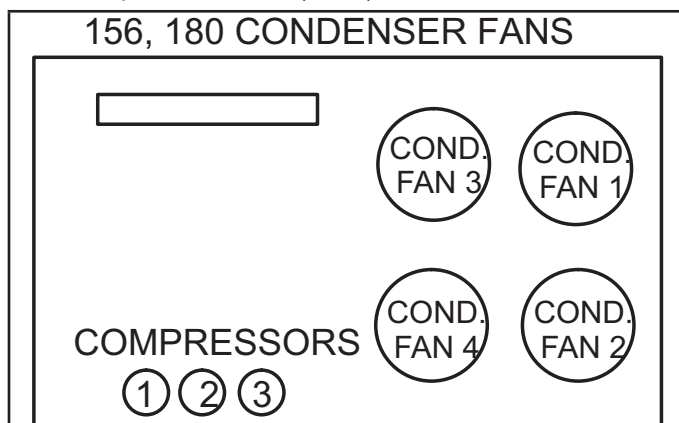


FIGURE 28

## 210, 240 & 300

Condenser fans 1, 2, and 3 are energized when compressor 1 or 2 are energized. As cooling demand increases, all six condenser fans are energized. Condenser fans 4, 5, and 6 are energized after a 2-second delay. See FIGURE 29.

Condenser fans 1, 2, 4, and 5 are de-energized when outdoor temperature drops below 55°F (13°C).

Condenser fan 3 is modulated to maintain target liquid temperatures (refrigerant circuits 1 and 2 respectively) when outdoor temperature drops below 55°F (13°C).

Condenser fan 6 is modulated to maintain target liquid temperatures (refrigerant circuits 3 and 4 respectively) when outdoor temperature drops below 55°F (13°C).

### 5 - Temperature Thermistor Sensors (RT42-57)

Temperature thermistors are located on specific points for each refrigeration circuit. Temperature thermistors provide continuous temperature input to the unit controller for proper cooling operation as well as system protection. Controller logic will de-energize compressors for each refrigeration circuit when evaporator coil temperature falls below 32°F (0°C) to prevent evaporator freeze-up.

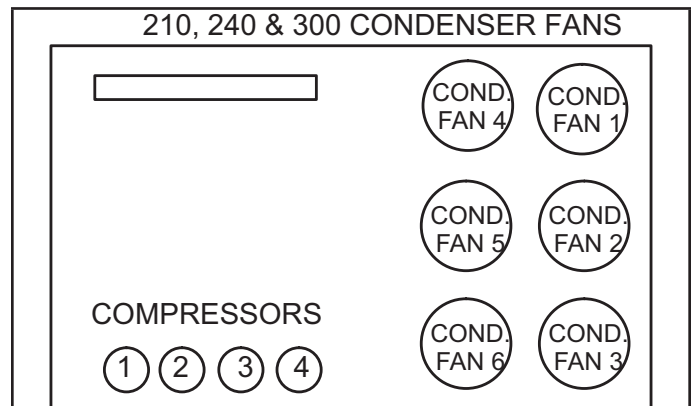


FIGURE 29

### 6 - Thermal Protector (S5)

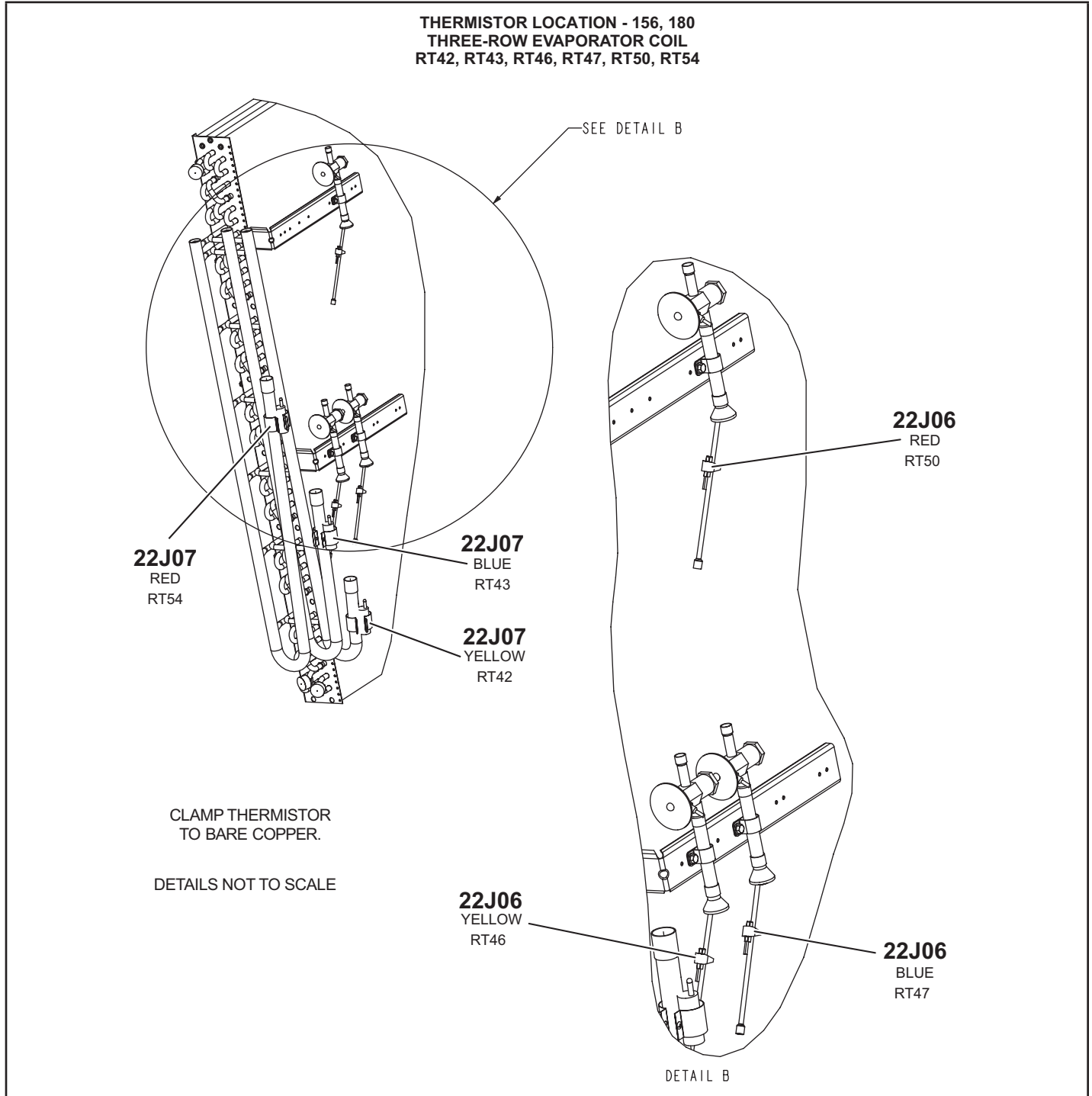
Each fixed-speed compressor is protected by an internal thermal protector switch. Variable speed compressors utilize an S5 external thermal protector.

## Diagnostic Sensors

Each thermistor must be specifically placed for proper unit operation and to initiate valid alarms. See TABLE 16 for proper locations.

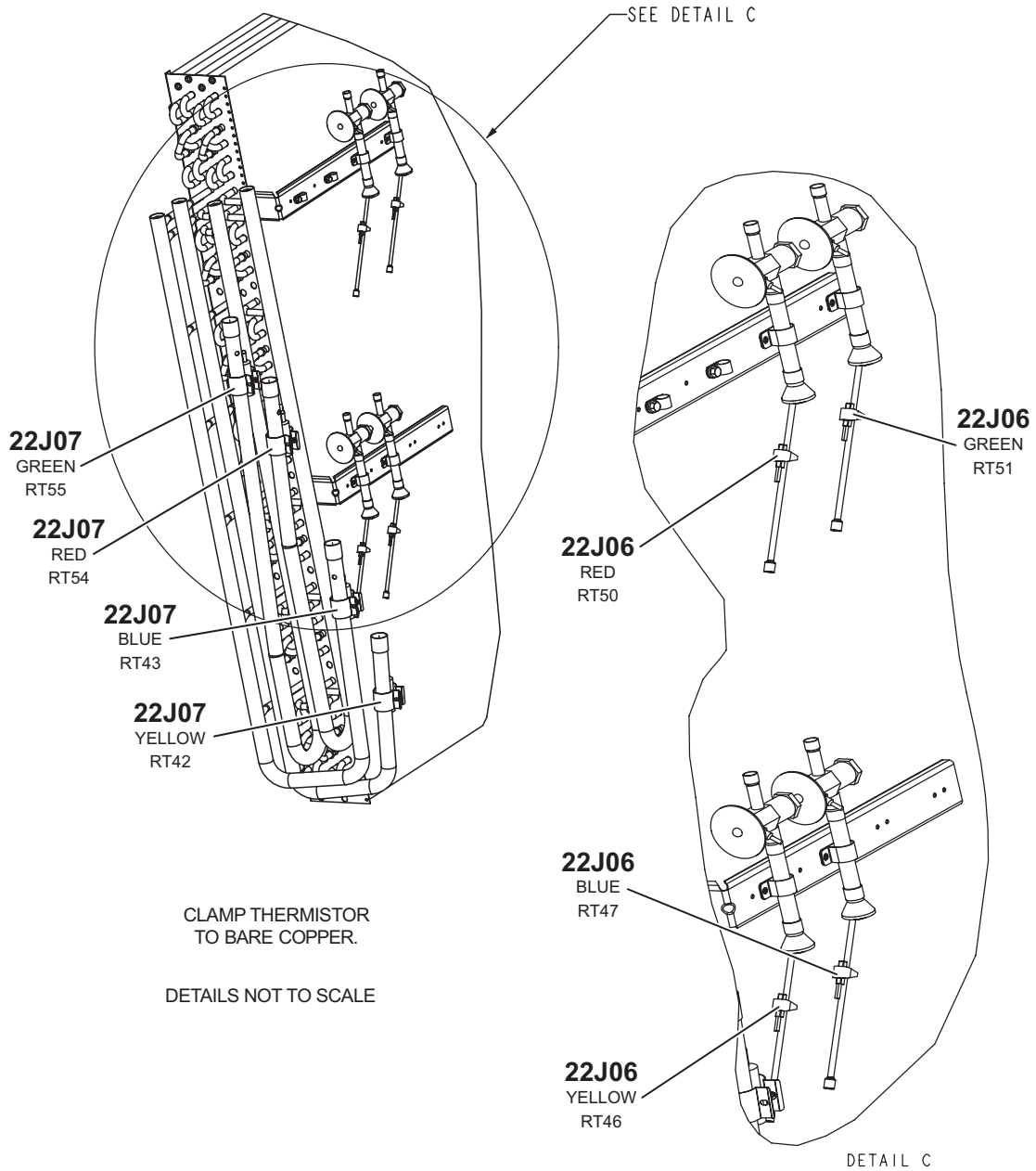
**TABLE 16  
THERMISTOR LOCATION**

Unit	Sensor	Figure
156, 180	RT42, 43, 46, 47, 50, 54	FIGURE 30
210, 240, 300	RT42, 43, 46, 47, 50, 51, 54, 55	FIGURE 31
156, 180	RT44, 45, 48, 49, 52, 56	FIGURE 32
210, 240, 300	RT44, 45, 48, 49, 52, 53, 56, 57	FIGURE 33



**FIGURE 30**

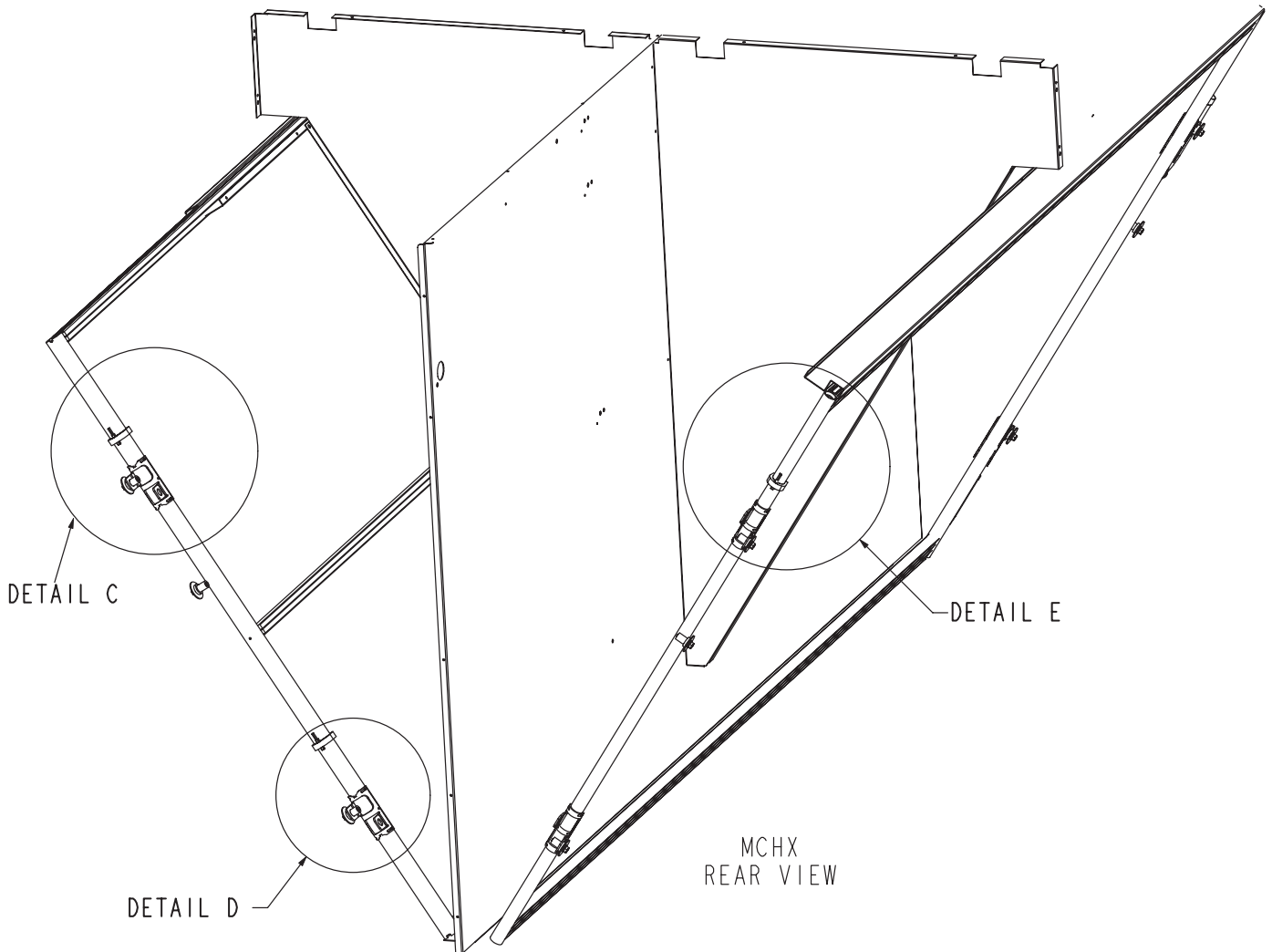
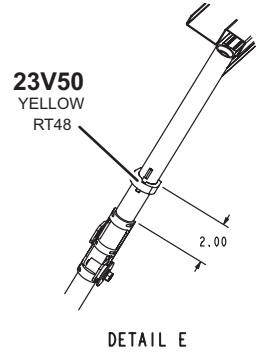
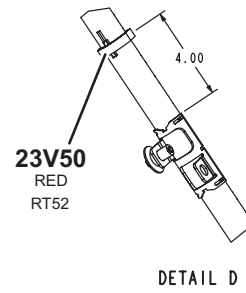
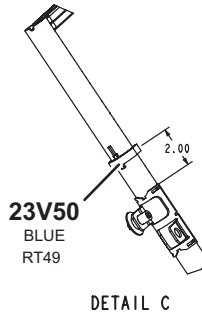
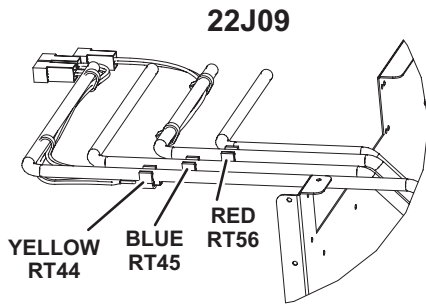
**THERMISTOR LOCATION - 210, 240, 300  
THREE-ROW EVAPORATOR COIL  
RT42, RT43, RT46, RT47, RT50, RT54**



**FIGURE 31**

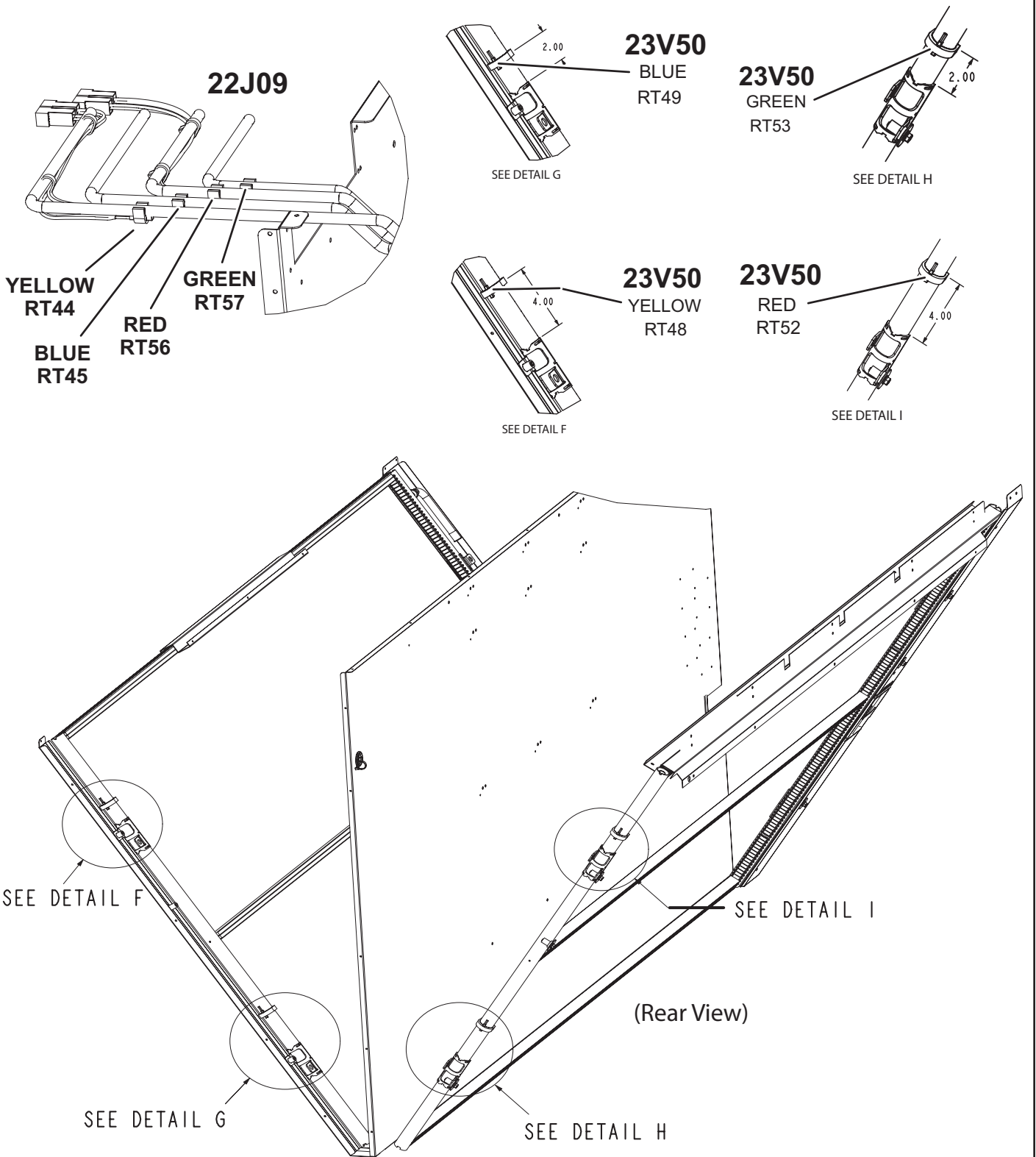


**THERMISTOR LOCATION - 156, 180  
CONDENSOR COIL  
RT44, RT45, RT48, RT49, RT52, RT56**



**FIGURE 32**

**THERMISTOR LOCATION - 210, 240, 300  
CONDENSOR COIL  
RT44, RT45, RT48, RT49, RT52, RT53, RT56, RT57**



**FIGURE 33**

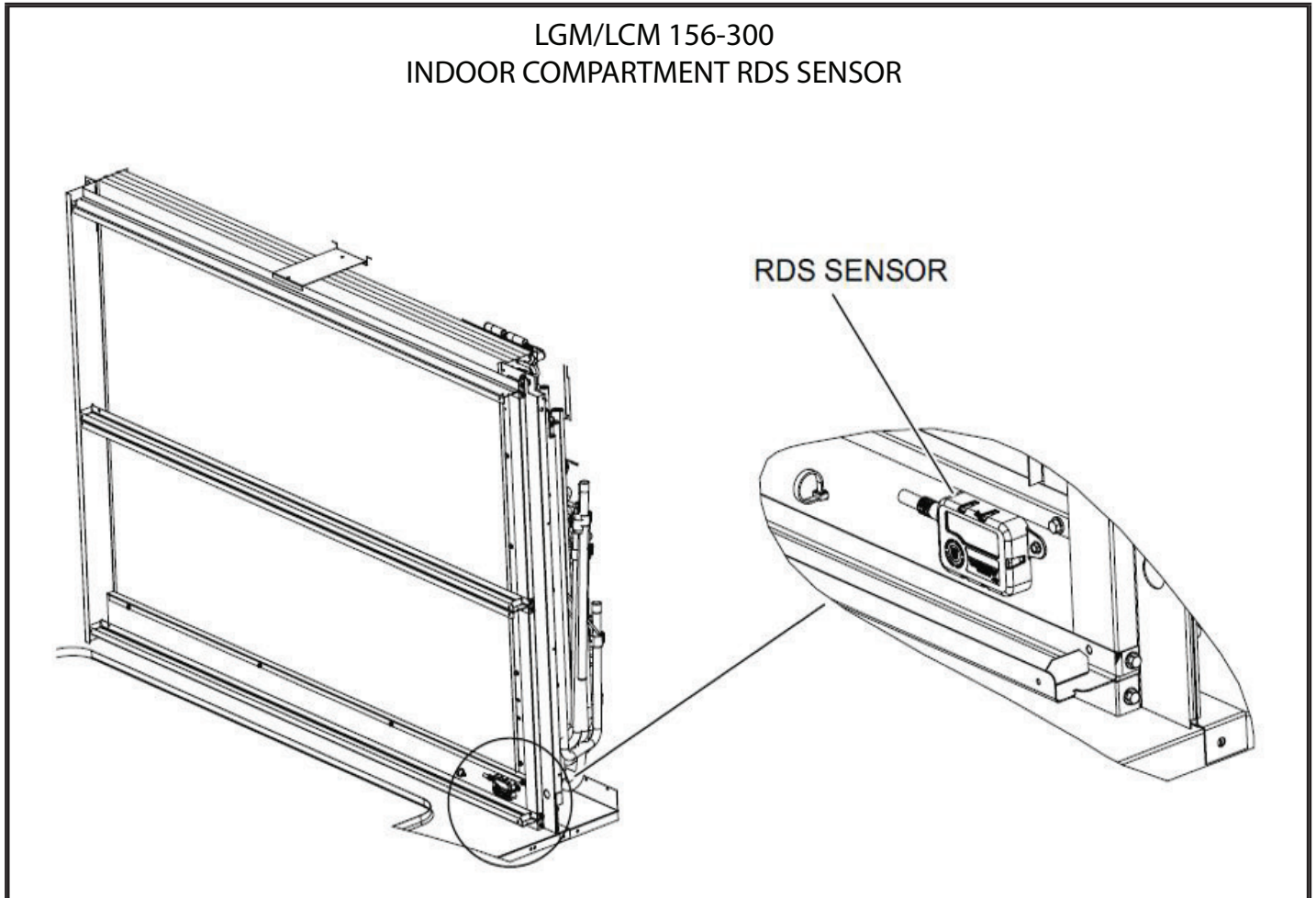
## RDS Sensors

Units are equipped with factory-installed RDS Sensors located on different points on the unit. The RDS sensors provide the Unit Controller with continuous readings for leaked refrigerant concentration levels and sensor health status (Good or Fault). These readings are used to modify unit operation to disperse the leaked refrigerant and to remove possible ignition sources. In addition, the Unit Controller uses these readings to initiate alarms to alert the operator of a refrigerant leak or faulty sensor(s).

Each sensor must be specifically placed for proper unit operation and to initiate valid alarms. To identify sensor locations see TABLE 17.

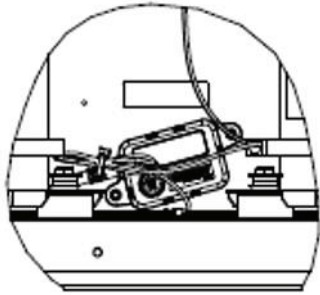
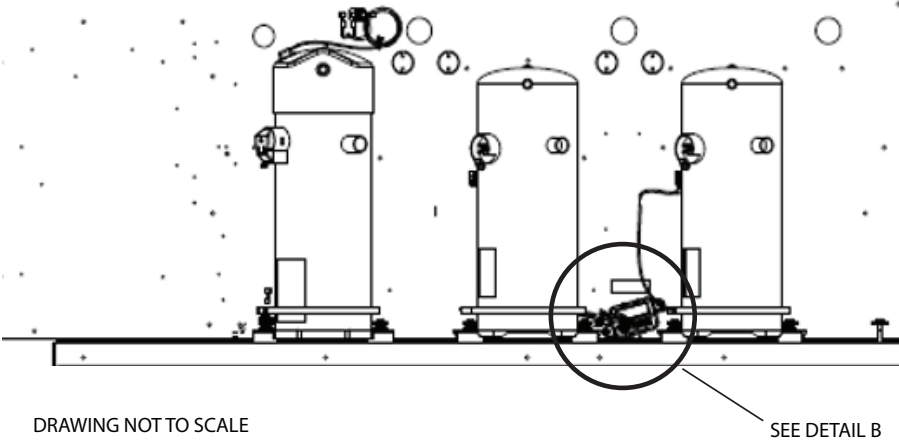
**TABLE 17**  
**RDS Sensor Figures**

Model	Qty.	Type	Figure
LGM/LCM156-180	2 sensors	INDOOR SENSOR	FIGURE 34
		COMPRESSOR SENSOR	FIGURE 35
LGM/LCM210-300	2 sensors	INDOOR SENSOR	FIGURE 34
		COMPRESSOR SENSOR	FIGURE 36



**FIGURE 34**

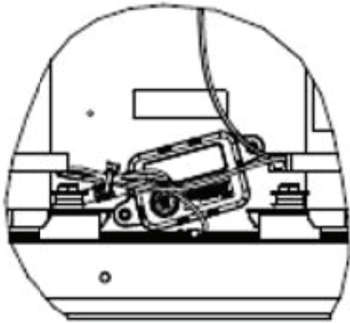
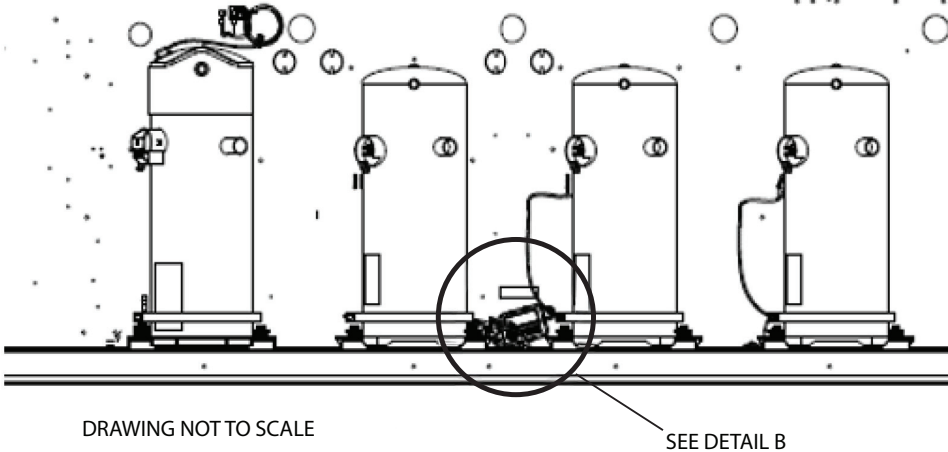
LGM/LCM 156-180  
COMPRESSOR RDS SENSOR



DETAIL B

FIGURE 35

LGM/LCM 210-300  
COMPRESSOR RDS SENSOR



DETAIL B

FIGURE 36

## Gas Heat Start-Up (Gas Units)

### FOR YOUR SAFETY READ BEFORE LIGHTING

**BEFORE LIGHTING** smell all around the appliance area for gas. Be sure to smell next to the floor because some gas is heavier than air and will settle on the floor.

Use only your hand to push in or turn the gas control knob. Never use tools. If the knob will not push in or turn by hand, do not try to repair it, call a qualified service technician. Force or attempted repair may result in a fire or explosion.

This unit is equipped with an automatic spark ignition system. There is no pilot. In case of a safety shutdown, move thermostat switch to OFF and return the thermostat switch to HEAT to reset ignition control.

## ⚠ WARNING



Electric shock hazard. Can cause injury or death. Do not use this unit if any part has been under water. Immediately call a qualified service technician to inspect the unit and to replace any part of the control system and any gas control which has been under water.

## ⚠ WARNING



Danger of explosion. Can cause injury or product or property damage. If overheating occurs or if gas supply fails to shut off, shut off the manual gas valve to the appliance before shutting off electrical supply.

## ⚠ WARNING



Electric shock hazard. Can cause injury or death. Before attempting to perform any service or maintenance, turn the electrical power to unit OFF at disconnect switch(es). Unit may have multiple power supplies.

## ⚠ WARNING

### SMOKE POTENTIAL

The heat exchanger in this unit could be a source of smoke on initial firing. Take precautions with respect to building occupants and property. Vent initial supply air outside when possible.

## ⚠ WARNING



Danger of explosion. Can cause injury or death. Do not attempt to light manually. Unit has a direct spark ignition system.

A-Placing Unit in Operation

## ⚠ WARNING



Danger of explosion and fire. Can cause injury or product or property damage. You must follow these instructions exactly.

Gas Valve Operation for Honeywell VR8205Q / VR8305Q and White Rodgers 36H54 (FIGURE 37)

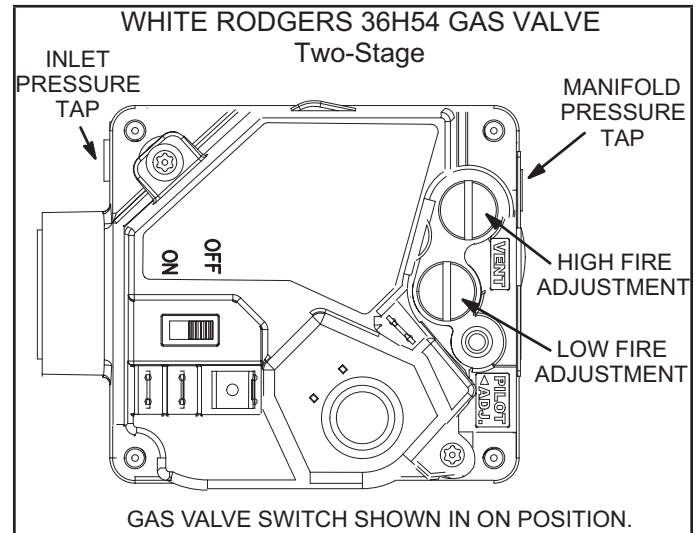


FIGURE 37

- 1 - Set thermostat to lowest setting.
- 2 - Turn off all electrical power to appliance.
- 3 - This appliance is equipped with an ignition device which automatically lights the burner. Do not try to light the burner by hand.
- 4 - Open or remove the heat section access panel.
- 5 - Turn gas valve switch to **OFF**. See FIGURE 37.
- 6 - Wait five (5) minutes to clear out any gas. If you then smell gas, **STOP!** Immediately call your gas supplier from a neighbor's phone. Follow the gas supplier's instructions. If you do not smell gas, go to the next step.
- 7 - Turn gas valve switch to **ON**. See FIGURE 37.
- 8 - Close or replace the heat section access panel.
- 9 - Turn on all electrical power to appliance.

- 10 - Set thermostat to desired setting.
- 11 - The ignition sequence will start.
- 12 - If the appliance does not light the first time (gas line not fully purged), it will attempt up to two more ignitions before locking out.
- 13 - If lockout occurs, repeat steps 1 through 10.
- 14 - If the appliance will not operate, follow the instructions "Turning Off Gas to Appliance" and call your service technician or gas supplier.

#### Turning Off Gas to Unit

- 1 - If using an electromechanical thermostat, set to the lowest setting.
- 2 - Before performing any service, turn off all electrical power to the appliance.
- 3 - Open or remove the heat section access panel.
- 4 - Turn gas valve switch to **OFF**.
- 5 - Close or replace the heat section access panel.

<b>⚠ WARNING</b>
<div style="display: flex; align-items: center;"> <div style="flex-grow: 1;"> <p style="margin: 0;">Danger of explosion. Can cause injury or death. Do not attempt to light manually. Unit has a direct spark ignition system.</p> </div> </div>

### Heating Operation and Adjustments

#### (Gas Units)

#### A-Heating Sequence of Operation

- 1 - On a heating demand the combustion air inducer starts immediately.
- 2 - Combustion air pressure switch proves inducer operation. After a 30-second pre-purge, power is allowed to ignition control. Switch is factory set and requires no adjustment.
- 3 - Spark ignitor energizes and gas valve solenoid opens.
- 4 - Spark ignites gas, ignition sensor proves the flame and combustion continues.

- 5 - If flame is not detected after first ignition trial, ignition control will repeat steps 3 and 4 two more times before locking out the gas valve.
- 6 - For troubleshooting purposes, an ignition attempt after lock out may be re-established manually. Move thermostat to **OFF** and return thermostat switch to **HEAT** position.

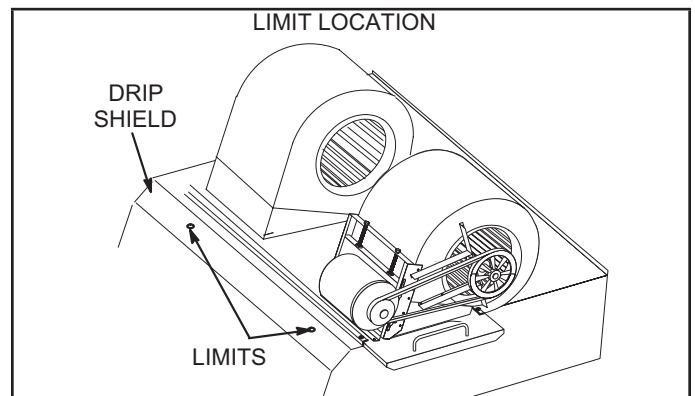
#### B-Limit Controls

Limit controls are factory-set and are not adjustable. Two limits are located on the drip shield in the blower compartment. See FIGURE 38.

#### C-Heating Adjustment

Main burners are factory-set and do not require adjustment. The following manifold pressures are listed on the gas valve.

- Natural Gas Units - Low Fire - 1.6" w.c. (not adjustable)
- Natural Gas Units - High Fire - 3.7" w.c.
- LP Gas Units - Low Fire - 5.5" w.c. (not adjustable)
- LP Gas Units - High Fire - 10.5" w.c.



**FIGURE 38**

### Electric Heat Start-Up (LCM Units)

#### Factory or Field-Installed Option

Electric heat will stage on and cycle with thermostat demand. Number of stages of electric heat will vary depending on electric heat assembly. See electric heat wiring diagram on unit for sequence of operation.



### Variable Air Volume Start-Up

Units contain a supply air blower equipped with a variable frequency drive A96 (VFD) which varies supply air CFM. The supply air VFD (A96) is located in the control area. See FIGURE 40.

#### A-Start-Up

- 1 - A pressure transducer (A30) is shipped in a box in the blower compartment. Install the transducer according to manufacturer's instructions.

**NOTE** - Make sure the transducer is installed in the main duct at least 2/3 of the distance away from the unit.

- 2 - Two twisted pairs of shielded cable must be used to connect the pressure transducer. See FIGURE 39. J/P378 connector is hanging in the control box.
- 3 - Open all zone dampers and/or boxes.
- 4 - Locate the A55 Unit Controller. Refer to FIGURE 40.
- 5 - Use the mobile service app to calibrate the blower CFM. Select this menu to start the blower:

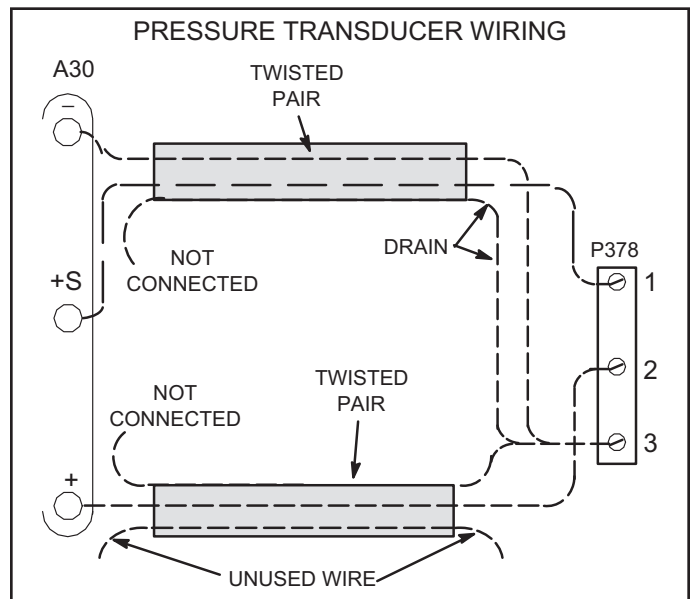
#### SETUP > TEST & BALANCE > BLOWER

The mobile app will display the percent of blower speed. Adjust blower speed percentage to meet design airflow specifications. Allow blower speed to stabilize.

- 6 - Press NEXT and follow the instructions to calibrate static pressure. If the static pressure meets the design specification, press NEXT again to set the setpoint. If the static pressure does not meet the design specification, adjust the pressure and press NEXT to set the setpoint.
- 7 - Record new setpoints in TABLE 18.

**TABLE 18  
RECORD ADJUSTED SETPOINTS**

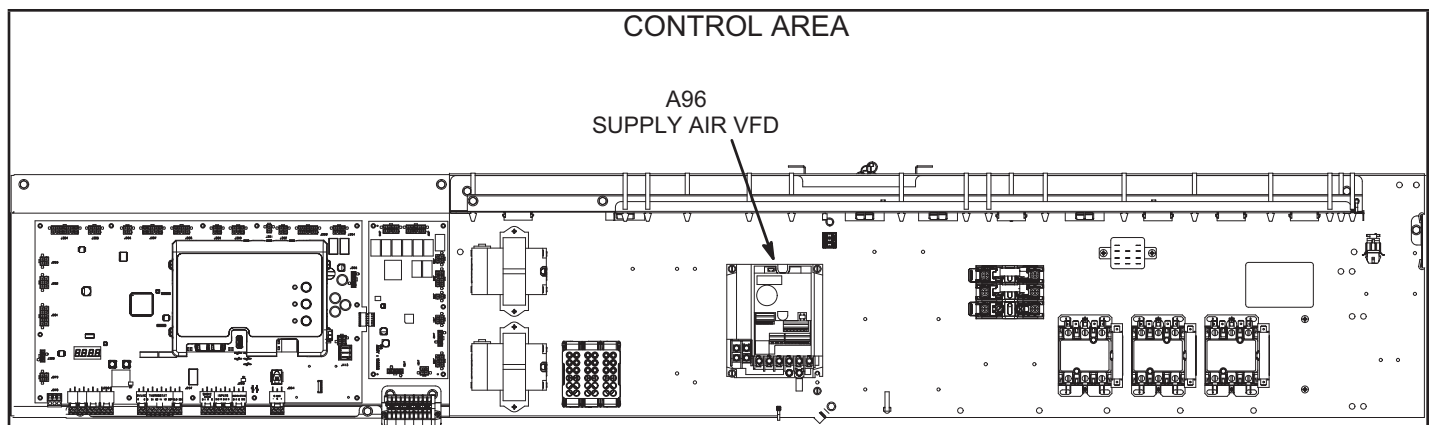
Parameter	Setpoint Description	Setpoint w.c.	Display Setting
386	Smoke		
387	Ventilation		
388	Heating		
389	Cooling		



**FIGURE 39**

**NOTE** - The Unit Controller will lock-out the unit for 5 minutes if static pressure exceeds 2.0" w.c. for 20 seconds. The Unit Controller will permanently shut down the unit after three occurrences. See mobile service app parameters 110, 42, and 43 to adjust default values.

- 8 - If the desired CFM cannot be met with current pulley setup, refer to the Blower Operation and Adjustments section to adjust CFM.



**FIGURE 40**



## B-Unit Operation

Use the mobile app to check unit mechanical operation. See the Service - Test section of the Unit Controller manual.

## C-Manual Supply Air VFD Bypass

**IMPORTANT - All dampers must be open to prevent damage to duct work and dampers.**

**NOTE - This section does not apply to units equipped with optional automatic VFD bypass. That option will automatically change from multi-stage air volume to constant air volume operation in the event of VFD failure.**

Manually change blower operation to constant air volume as follows:

- 1 - Disconnect all power to unit and WAIT AT LEAST 10 MINUTES before opening the VFD cover

**⚠ WARNING**

**ELECTRICAL SHOCK HAZARD**

STOP! Before you continue, make sure that power to the VFD has been off for at least 10 minutes. The capacitor in the VFD holds high voltage power for up to 10 minutes after power has been disconnected.

- 2 - Locate P246 and P247 connectors near the VFD. See FIGURE 41.
- 3 - Disconnect P246 from P246 (power in to VFD) and P247 from P247 (power out to blower). See FIGURE 42.
- 4 - Connect P246 to P247. See FIGURE 43.

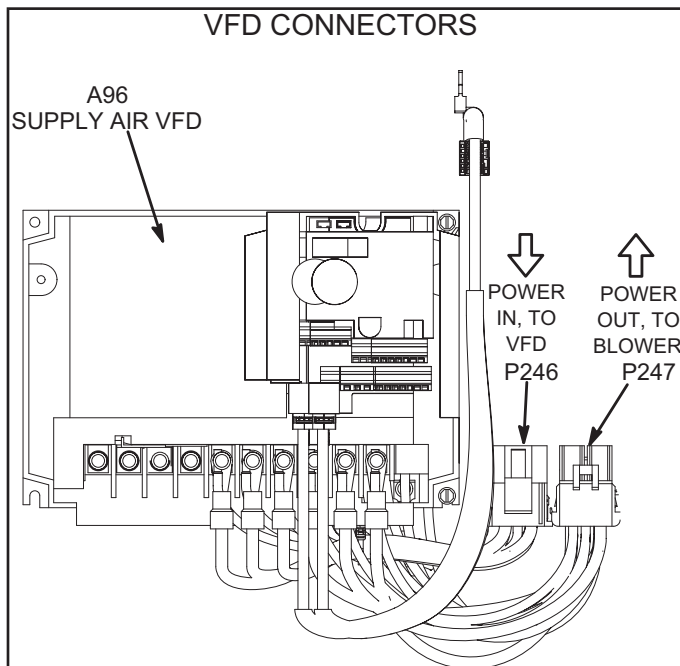


FIGURE 41

- 5 - Restore power to unit. Blower will operate in constant air volume (CAV) mode.

**NOTE - The indoor blower motor will start as soon as the main unit power is restored. In manual bypass, the blower will run regardless of thermostat signals until main unit power is turned off. Manual bypass is meant for emergency operation only and not long-term usage.**

- 6 - Check the indoor blower motor nameplate for full load amperage (FLA) value. Measure the amp readings from the indoor blower motor operating in bypass mode. If measured amps are higher than nameplate FLA value, decrease the CFM by opening (turning counterclockwise) the motor pulley. See FIGURE 21. Do not exceed minimum and maximum number of pulley turns as shown in TABLE 4.

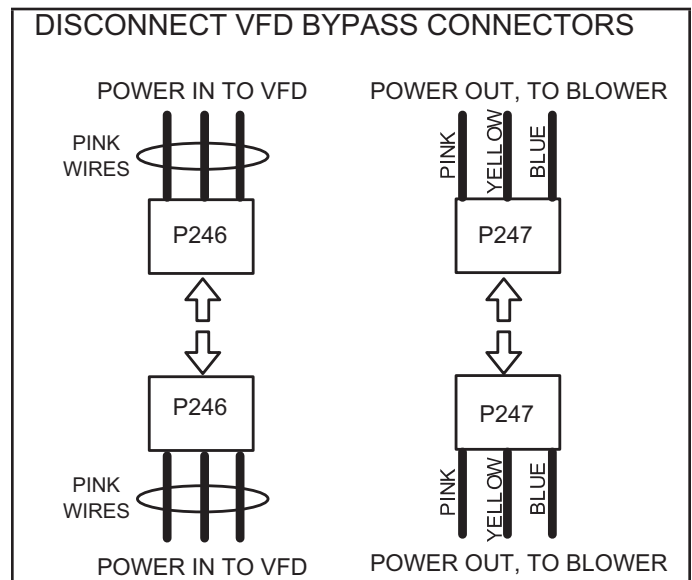


FIGURE 42

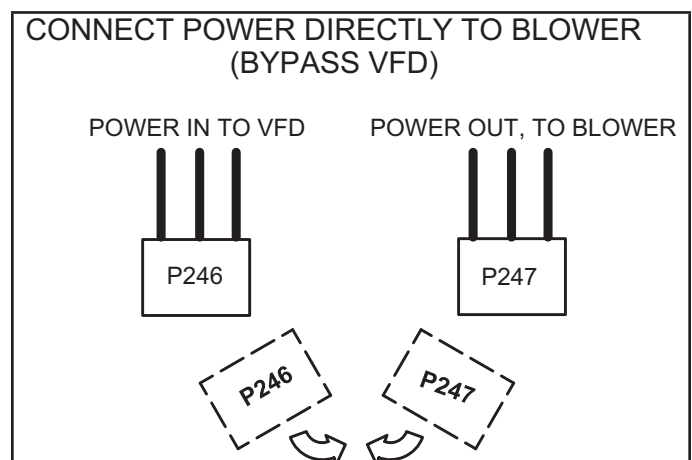


FIGURE 43

## Multi-Staged Air Volume Start-Up

### A-Design Specifications

Use TABLE 19 to fill in field-provided, design specified blower CFM for appropriate unit.

If only high and low cooling design specifications are provided, set the medium cooling CFM at the high or low cooling design spec or any CFM between.

### B-Set Maximum CFM

Use TABLE 21 to determine highest blower CFM for appropriate unit. Adjust the blower pulley to deliver that amount of CFM with only the blower operating. See Determining Unit CFM in the Blower Operation and Adjustment section.

### C-Set Blower Speeds

- 1 - Use the following mobile service app menu to enter the blower design specified CFM into the Unit Controller. Make sure blower CFM is within limitations shown in TABLE 20 or TABLE 21. Refer to the Unit Controller manual provided with unit.

#### RTU MENU > RTU OPTIONS > BLOWER > SPEED

- 2 - Enter the following design specifications as shown in TABLE 19.

*Blower / Heat CFM*

*Cooling High CFM*

*Cooling Low CFM*

*Vent CFM*

- 3 - Adjust the blower RPM to deliver the target CFM based on the measured static pressure using the blower table.
- 4 - Measure the static pressure again and apply the static pressure and RPM to the blower tables to determine adjusted CFM.
- 5 - Repeat adjustments until design CFM is reached.

### D-Set Damper Minimum Position

To maintain required minimum ventilation air volumes when the unit is in the occupied mode, two minimum damper positions must be set.

*The Unit Controller will open the damper to "Min OCP Blwr High" when blower CFM is at or ABOVE the "midpoint" CFM.*

*The Unit Controller will open the dampers to "Min OCP Blwr Low" when blower CFM is BELOW a "midpoint" CFM.*

The Unit Controller will calculate the "midpoint" CFM.

**TABLE 19**  
**Blower CFM Design Specifications**

Unit	T'Stat or Zone Control Stages	Blower Speed	Design Specified CFM
156	2	Htg.	
		Clg. High	
		Clg. Low	
		Ventilation	
180	2	Htg.	
		Clg. High	
		Clg. Low	
		Ventilation	
210	2	Htg.	
		Clg. High	
		Clg. Low	
		Ventilation	
240	2	Htg.	
		Clg. High	
		Clg. Low	
		Ventilation	
300	2	Htg.	
		Clg. High	
		Clg. Low	
		Ventilation	

\*Available blower speeds vary by unit and thermostat stages.

#### Set Minimum Position 1

Use the following mobile service app menu to set "Min OCP Blwr High" for the blower CFM above the "midpoint" CFM. When navigating into this menu, the Unit Controller will run damper calibration and allow damper position adjustment.

#### RTU MENU > SETTINGS > RTU OPTIONS > DAMPER

Tap "Next" to skip tabs and complete damper position calibration until "Damper Calibration Blower Speed High" tab appears.

Measure the intake air CFM. If the CFM is lower than the design specified CFM for ventilation air, use the Unit Controller to increase the damper percent open. If the CFM is higher than specified, decrease the damper percent open.

**NOTE** - Intake air CFM can also be determined using the outdoor air temperature, return air temperature and mixed air temperature. Refer to the economizer or outdoor air damper installation instructions.

**TABLE 20  
HEATING, VENTILATION, & SMOKE MINIMUM AND MAXIMUM CFM**

Unit			Heating CFM			Vent CFM			Smoke CFM		
Model	Speed	Heat Code	Min.	Default	Max.	Min.	Default	Max.	Min.	Default	Max.
LGM156U	Low, Std, Med	L, S, M	3000	5200	6250	800	1150	*	1950	5200	6250
LGM180U	Low, Std, Med	L, S, M	3000	6000	7200	800	1325	*	2250	6000	7200
LGM180U	High	H	5125								
LGM210U	Low, Std, Med	L, S, M	3000	7000	8400	800	1550	*	2625	7000	8400
LGM210U	High	H	5125								
LGM240U	Low, Std, Med	L, S, M	4500	8000	9600	800	1750	*	3000	8000	9600
LGM240U	High	H	5125								
LGM300U	Low, Std, Med	L, S, M	4500	10000	12000	800	2200	*	3750	10000	12000
LGM300U	High	H	5125								
LCM156U	All	N, E, J, K, L, P	5200	5200	6250	800	1150	*	1950	5200	6250
LCM180U	All	N, E, J, K, L, P	6000	6000	7200	800	1325	*	2250	6000	7200
LCM210U	All	N, E, J, K, L, P	6000	7000	8400	800	1550	*	2625	7000	8400
LCM240U	All	N, E, J, K, L, P	6000	8000	9600	800	1750	*	3000	8000	9600
LCM300U	All	N, E, J, K, L, P	6000	10000	12000	800	2200	*	3750	10000	12000

\*Use highest value between Heating and Cooling High CFM Max.

**TABLE 21  
COOLING MINIMUM AND MAXIMUM CFM**

LGM/ LCM Unit	Cooling Low CFM			Cooling High CFM		
	Default	Min.	Max.	Default	Min.	Max.
156U	1150	800	*	4550	3250	6240
180U	1325	800	*	5250	3750	7200
210U	1550	800	*	6125	4375	8400
240U	1750	800	*	7000	5000	9600
300U	2200	800	*	8750	6250	12000

\*Use Cooling High CFM Max.

**Set Minimum Position 2**

Use the following mobile service app menu in the Unit Controller to set “Min OCP Blwr Low” for the blower CFM below the “midpoint” CFM. When navigating into this menu, the Unit Controller will run damper calibration and allow damper position adjustment.

**RTU MENU > SETTINGS > RTU OPTIONS > DAMPER**

Tap “Next” to skip tabs and complete damper position calibration until “Damper Calibration Blower Speed High” tab appears.

Measure the intake air CFM. If the CFM is lower than the design specified CFM for ventilation air, use the Unit Controller to increase the damper percent open. If the CFM is higher than specified, decrease the damper percent open.

**NOTE** - Intake air CFM can also be determined using the outdoor air temperature, return air temperature and mixed air temperature. Refer to the economizer or outdoor air damper installation instructions.

**E-Inverter Bypass Option**

The supply air inverter is factory-set to by-pass the inverter manually. To by-pass the inverter and operate the blower in the constant air volume mode, use the following Unit Controller menu and set to “engaged”:

**SETTINGS > RTU OPTIONS > BLOWER > VFD BY-PASS**

To configure the unit to by-pass the inverter automatically, use the following Unit Controller menu.

**SETUP > INSTALL**

Press SAVE until the menu reads:

**CONFIGURATION ID 1**

Change the 6th character position to A for automatic bypass option.

Press SAVE

**CAUTION** - Units not equipped with an inverter will have the 6th character set to N, indicating the inverter is not bypassed. The blower motor could be damaged and/or result in product or property damage if the setting is changed to automatic or manual.

## Multi-Staged Air Volume Operation

This is a summary of cooling operation. Refer to the sequence of operation provided in the Engineering Handbook or Service Manual for more detail.

**NOTE** - During a dehumidification demand the blower operates at the highest speed. Free cooling is locked-out during reheat operation. Refer to reheat start-up and operation section for details.

### A-Two-Stage T'Stat / Zone Sensor; 3-and 4-Compressor Units

#### 1 - Economizer With Outdoor Air Suitable

##### Y1 Demand -

Compressors Off  
Blower Cooling Low  
Dampers modulate

##### Y2 Demand -

Compressors Off  
Blower Cooling High  
Dampers Modulate

If dampers are at maximum open for three minutes, compressor 1 and 2 are energized and blower stays on cooling high.

#### 2 - No Economizer or Outdoor Air Not Suitable

##### Y1 Demand -

Compressor 1 (variable speed) On  
Remaining compressors are energized in order to maintain discharge air temperature (DAT) rises above target

Blower Cooling Low  
Dampers Minimum Position

##### Y2 Demand -

Compressor 1 (variable speed) On  
Remaining compressors are energized in order to maintain discharge air temperature (DAT) rises above target

Blower Cooling High  
Dampers Minimum Position

### B-Three-Stage T'Stat / Zone Sensor 3 and 4 Compressor Units AND Zone Sensor (4 Clg. Stages), 3-Compressor Units

#### 1 - Economizer With Outdoor Air Suitable

##### Three-Compressor Units

##### Y1 Demand -

Compressors Off  
Blower Cooling Low  
Dampers Modulate

##### Y2 Demand -

Compressors Off  
Blower Cooling Adjustable from Med to High  
Dampers Modulate

**NOTE** - If dampers are at maximum open for three minutes, compressor 1 is energized and blower stays on cooling high.

##### Y3 Demand -

Compressor 1 (variable speed) On

Remaining compressors are energized in order to maintain discharge air temperature (DAT) rises above target

Blower Cooling High  
Dampers Maximum Open

##### Four-Compressor Units

##### Y1 Demand -

Compressors Off  
Blower Cooling Low  
Dampers Modulate

##### Y2 Demand -

Compressors Off  
Blower Cooling Adjustable from Med to High  
Dampers Modulate

If dampers are at maximum open for three minutes, compressors 1 and 2 are energized and blower stays on cooling high.

##### Y3 Demand -

Compressor 1 (variable speed) On

Remaining compressors are energized in order to maintain discharge air temperature (DAT) rises above target

Blower Cooling High  
Dampers Maximum Open

#### 2 - No Economizer or Outdoor Air Not Suitable

##### Three- and Four-Compressor Units

##### Y1 Demand -

Compressor 1 (variable speed) On

Remaining compressors are energized in order to maintain discharge air temperature (DAT) rises above target

Blower Cooling Low

##### Y2 Demand -

Compressors 1 (variable speed) On

Remaining compressors are energized in order to maintain discharge air temperature (DAT) rises above target

Blower Cooling Adjustable from Med to High

##### Y3 Demand -

Compressors 1 (variable speed) On

Remaining compressors are energized in order to maintain discharge air temperature (DAT) rises above target

Blower Cooling High

## Hot Gas Reheat Start-Up and Operation

### General

Hot gas reheat units provide a dehumidifying mode of operation. These units contain a reheat coil adjacent to and downstream of the evaporator coil. Reheat coil solenoid valves, L14 and L30, route hot discharge gas from the compressor to the reheat coil. Return air pulled across the evaporator coil is cooled and dehumidified; the reheat coil adds heat to supply air.

See FIGURE 44 for 156 and 180 reheat refrigerant routing, FIGURE 45 for 156 and 180 normal cooling refrigerant routing, FIGURE 46 for 210, 240, and 300 reheat refrigerant routing and FIGURE 47 for 210, 240, and 300 normal cooling refrigerant routing.

### L14 and L30 Reheat Coil Solenoid Valves

When Unit Controller (P298-5 or J299-8) indicates room conditions require dehumidification, See FIGURE 10 through FIGURE 12. L14 and L30 reheat valves are energized (Unit Controller J394-1 or J394-3) and refrigerant is routed to the reheat coil.

### Reheat Setpoint

Reheat is factory-set to energize when indoor relative humidity rises above 60% (default). The reheat setpoint can be adjusted by changing mobile service app *Settings - Control* menu. A setting of 100% will operate reheat from an energy management system digital output. The reheat setpoint can also be adjusted using an optional Network Control Panel (NCP).

Reheat will terminate when the indoor relative humidity falls 3% (57% default) or the digital output de-energizes. The reheat deadband can be adjusted at *Settings - Control* menu.

### A91 Humidity Sensor

Relative humidity should correspond to the sensor (A91) output voltage listed in TABLE 22. For example: if indoor air relative humidity is 80% + 3%, the humidity sensor output should read 8.00VDC.

Check the sensor output annually for accuracy. Keep the air intake openings on the sensor clean and free of obstructions and debris.

TABLE 22

Relative Humidity (%RH + 3%)	Sensor Output (VDC)
20	2.00
30	3.00
40	4.00
50	5.00
60	6.00
70	7.00
80	8.00
90	9.00

### Check-Out

Test hot gas reheat operation using the following procedure.

- 1 - Make sure reheat is wired as shown in wiring section.
- 2 - Make sure unit is in local thermostat mode.
- 3 - Use mobile service app menu path to select:

#### SERVICE > TEST > DEHUMIDIFIER

The blower, compressor 1 and compressor 2 (reheat) should be operating. Reheat mode will appear on the mobile service app display.

- 4 - Deselect:

#### SERVICE > TEST > DEHUMIDIFIER

Compressor 1 and 2 (reheat) should de-energize, blower should still be energized.

#### Default Reheat Operation

Reheat will operate as shown in TABLE 23 once this condition is met:

- 1 - System must NOT be operating in heating mode.

### IMPORTANT - Free cooling does not operate during reheat.

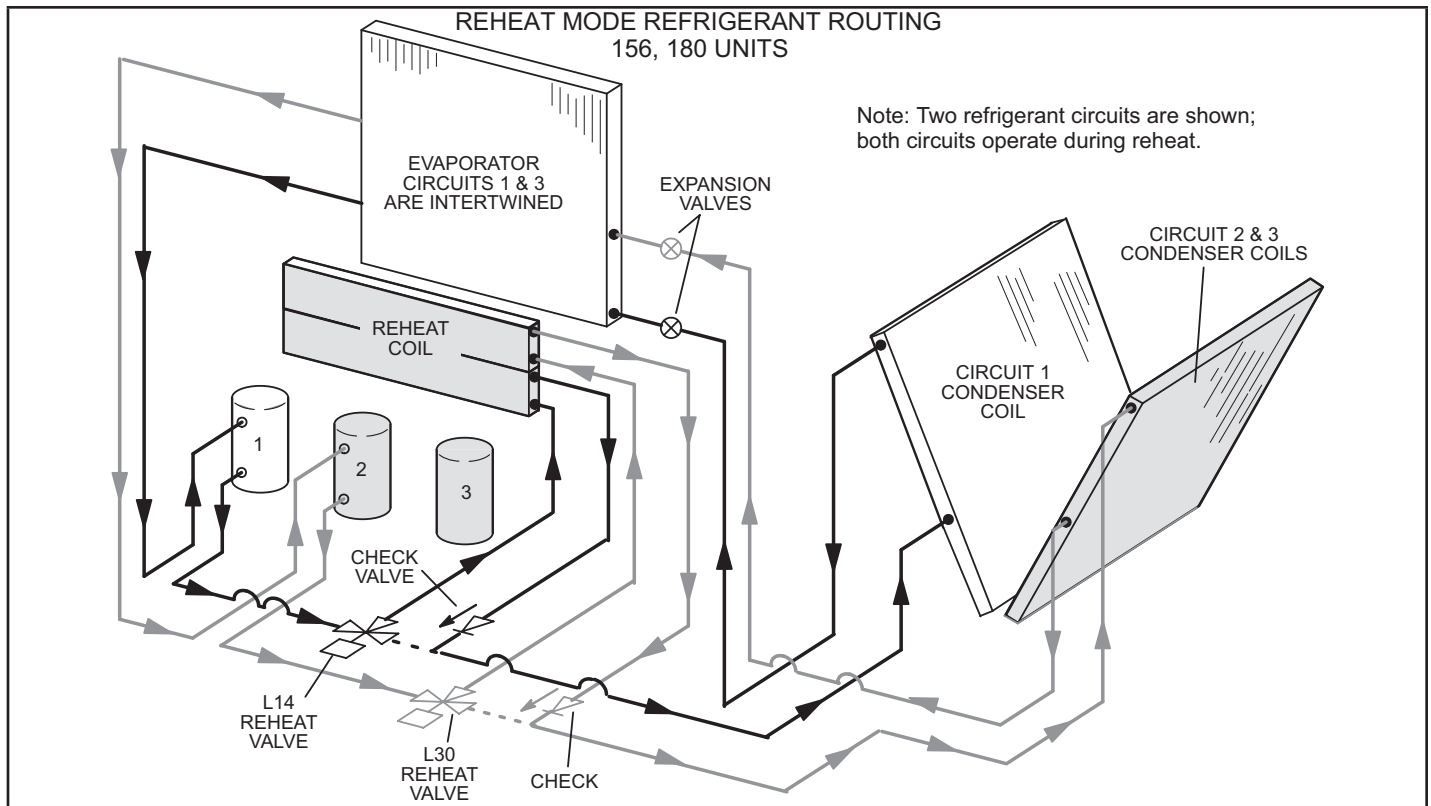
For other reheat control options, refer to the Unit Controller manual.

#### Additional Cooling Stages

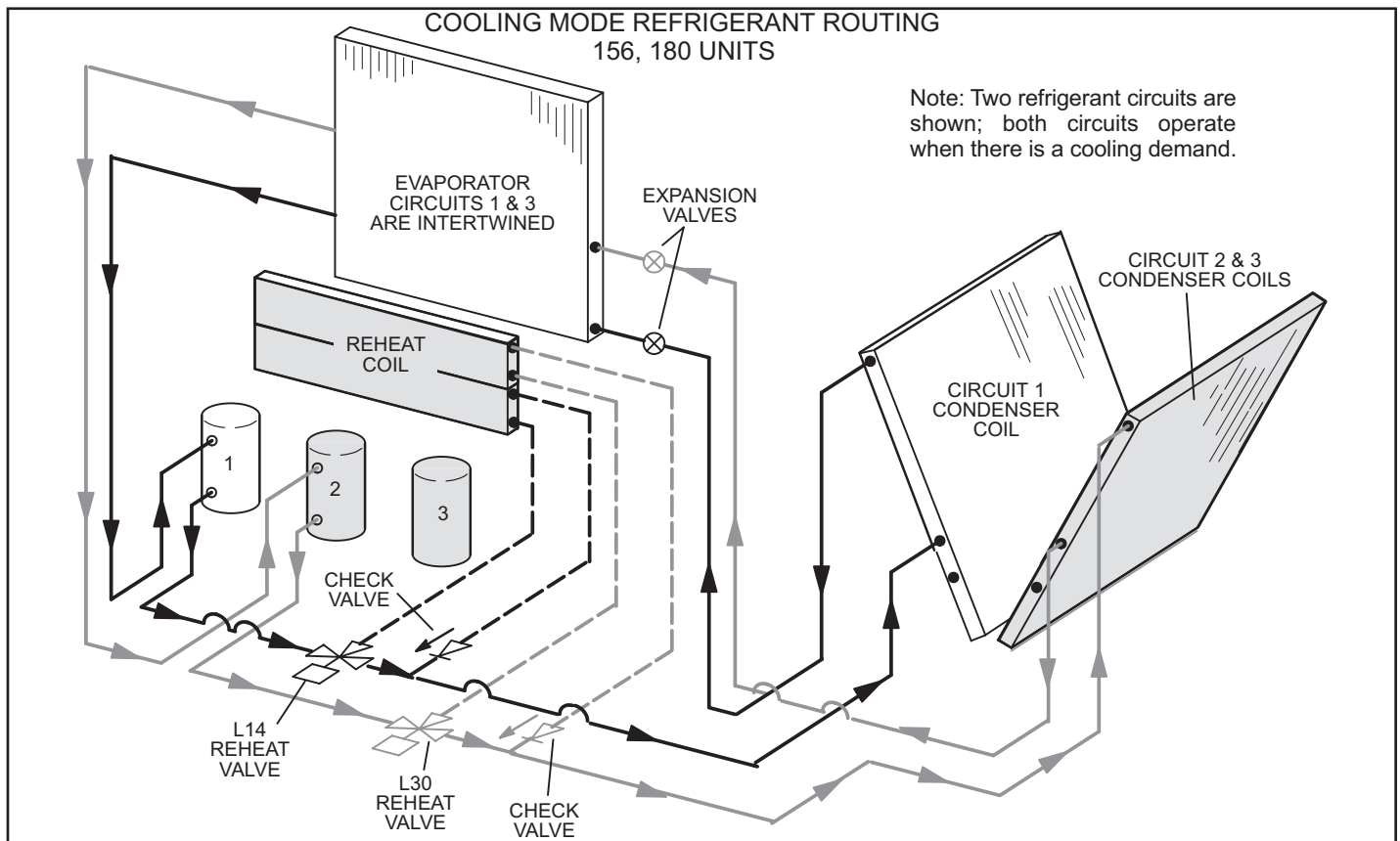
Units are shipped from the factory to provide two stages of cooling.

Compressors are not de-energized when unit operation changes from cooling to reheat or from reheat to cooling. Instead, L14 and L30 reheat valves are energized (reheat) or de-energized (cooling).

**NOTE** - Another thermostat staging option is available which allows both compressors to be energized during free cooling. See Unit Controller manual for details.

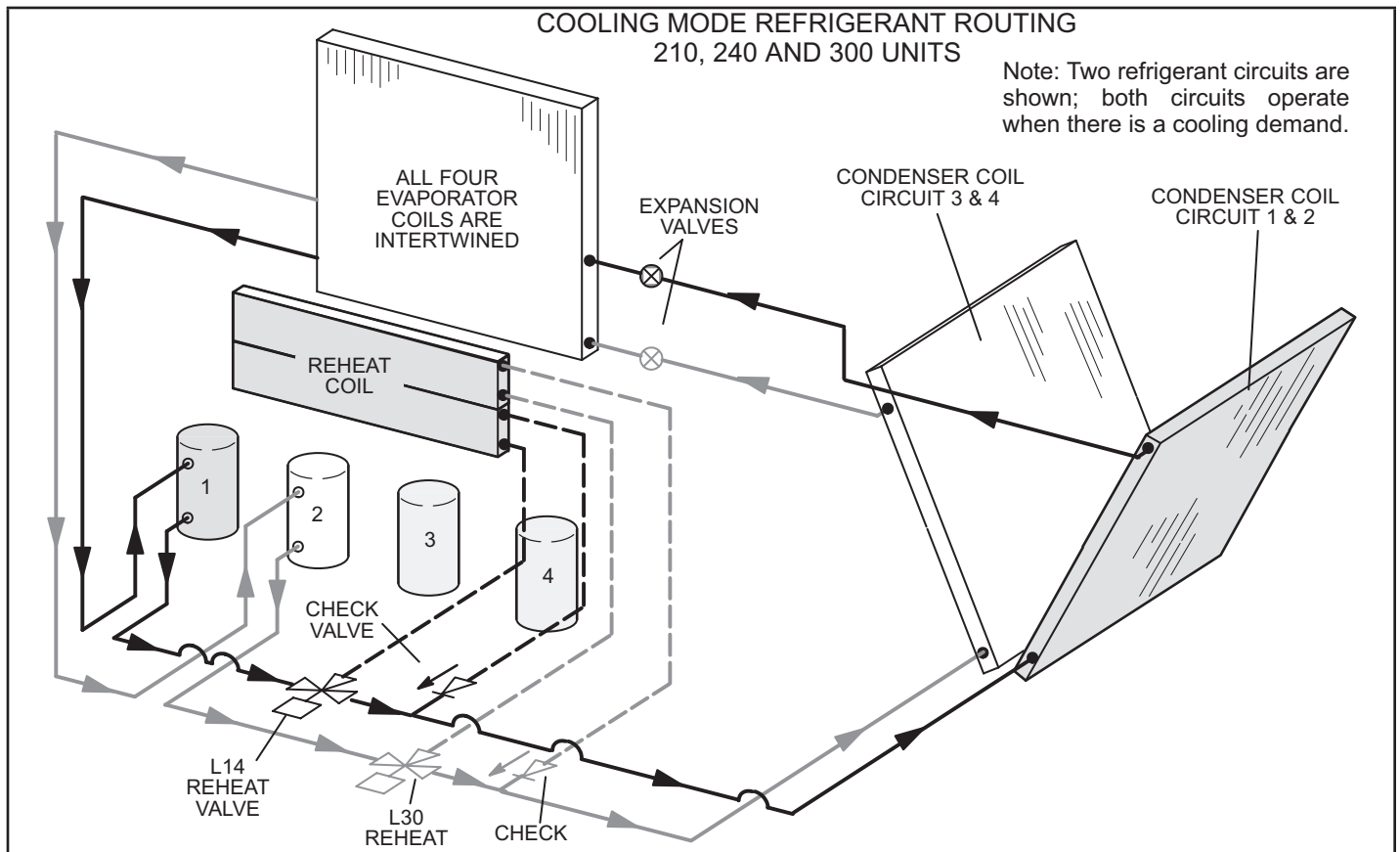
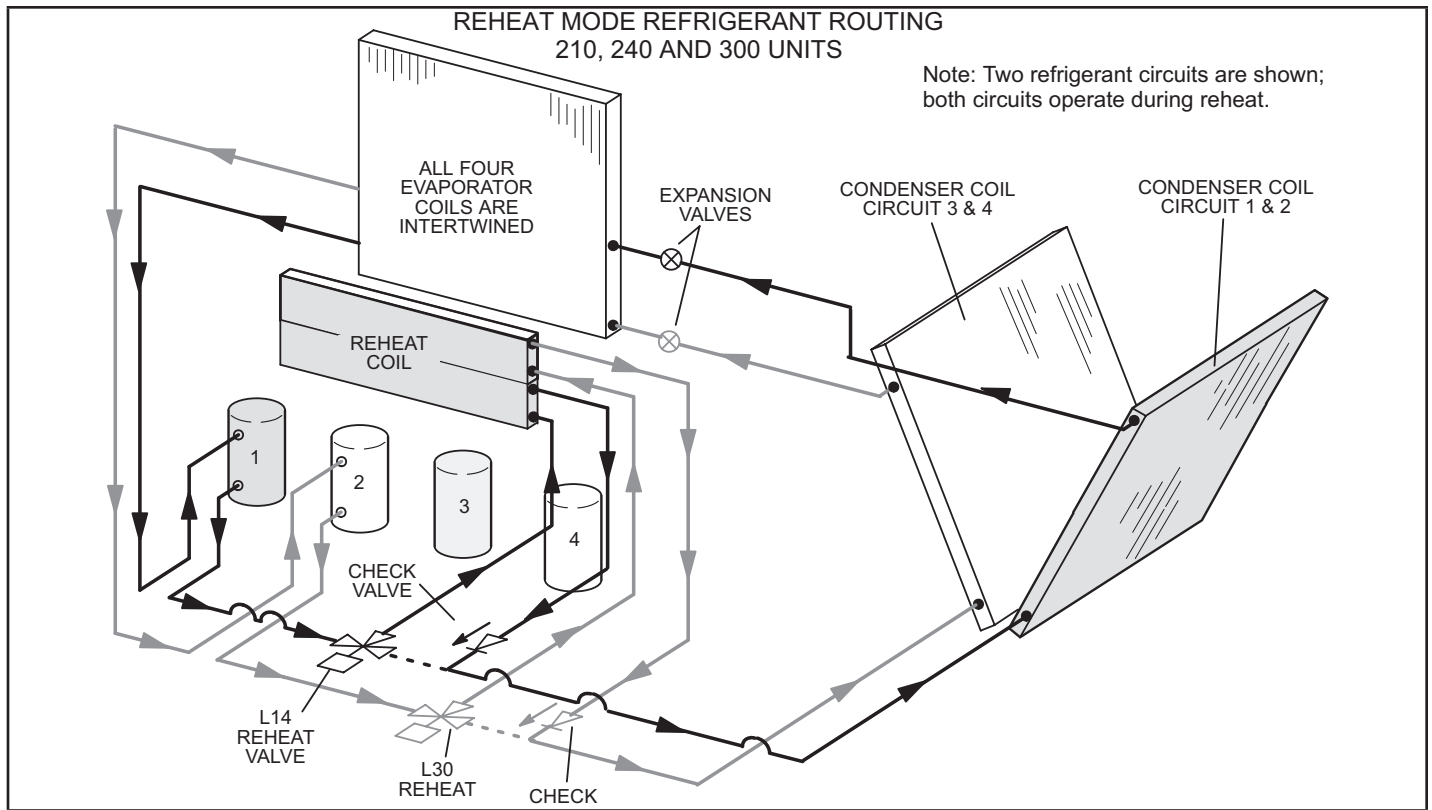


**FIGURE 44**



**FIGURE 45**







**TABLE 23  
REHEAT OPERATION**

<b>Thermostat Mode with 24V Humidistat</b>	
<b>Humidity Demands</b>	<b>Operation</b>
24V Demand for Dehumidification Only	<ul style="list-style-type: none"> <li>• Compressor 1 reheat on</li> <li>• Compressor 1 operates at 100%</li> <li>• Reheat valve is energized</li> <li>• Remaining compressors are staged based on discharge air temperature</li> <li>• Blower and outdoor fans modulate to maintain indoor coil and discharge air temperatures</li> </ul>
24V Demand for Dehumidification only is still present after Five Minutes	<ul style="list-style-type: none"> <li>• Compressor 1 &amp; 2 reheat on</li> <li>• Compressor 1 operates at 100%</li> <li>• Reheat valves are energized</li> <li>• Remaining compressor(s) are staged based on discharge air temperature.</li> <li>• Blower and outdoor fans modulate to maintain indoor coil and discharge air temperatures</li> </ul>
<b>Thermostat Mode with Zone Relative Humidity (RH) Sensor</b>	
Zone humidity is greater than Setpoint +2%	<ul style="list-style-type: none"> <li>• Compressor 1 reheat on</li> <li>• Compressor 1 modulates to maintain zone RH</li> <li>• Reheat valve is energized</li> <li>• Remaining compressors are staged based on discharge air temperature.</li> <li>• Blower and outdoor fans modulate to maintain indoor coil and discharge air temperatures</li> </ul>
Zone humidity is greater than Setpoint +2% OR Zone humidity is greater than Setpoint for 5 minutes	<ul style="list-style-type: none"> <li>• Compressor 1 &amp; 2 reheat on</li> <li>• Compressor 1 modulates to maintain zone RH</li> <li>• Reheat valves are energized</li> <li>• Remaining compressor(s) are staged based on discharge air temperature.</li> <li>• Blower and outdoor fans modulate to maintain indoor coil and discharge air temperatures</li> </ul>

**NOTE** - Compressors are not engaged while unit is in re-heat mode. They will stage accordingly to maintain discharge air temperature.

## Preventative Maintenance / Repair

### IMPORTANT MAINTENANCE / REPAIR SAFETY INSTRUCTIONS

Prior to beginning work on systems containing FLAMMABLE REFRIGERANTS, safety checks are necessary to ensure that the risk of ignition is minimized.

Work shall be undertaken under a controlled procedure to minimize the risk of a flammable gas or vapor being present while the work is being performed.

All maintenance staff and others working in the local area shall be instructed on the nature of work being carried out. Work in confined spaces shall be avoided.

The area shall be checked with an appropriate refrigerant detector prior to and during work, to ensure the technician is aware of potentially toxic or flammable atmospheres. Ensure that the leak detection equipment being used is suitable for use with all applicable refrigerants, i.e. non-sparking, adequately sealed or intrinsically safe.

If any hot work is to be conducted on the refrigerating equipment or any associated parts, appropriate fire extinguishing equipment shall be available to hand. Have a dry powder or CO2 fire extinguisher adjacent to the charging area.

No person carrying out work in relation to a REFRIGERATING SYSTEM which involves exposing any pipe work shall use any sources of ignition in such a manner that it may lead to the risk of fire or explosion. All possible ignition sources, including cigarette smoking, should be kept sufficiently far away from the site of installation, repairing, removing and disposal, during which refrigerant can possibly be released to the surrounding space. Prior to work taking place, the area around the equipment is to be surveyed to make sure that there are no flammable hazards or ignition risks. "No Smoking" signs shall be displayed.

Where electrical components are being changed, they shall be fit for the purpose and to the correct specification. At all times, the manufacturer's maintenance and service guidelines shall be followed. If in doubt, consult the manufacturer's technical department for assistance.

Repair and maintenance to electrical components shall include initial safety checks and component inspection procedures. If a fault exists that could compromise safety, then no electrical supply shall be connected to the circuit until it is satisfactorily dealt with. If the fault cannot be corrected immediately but it is necessary to continue operation, an adequate temporary solution shall be used. This shall be reported to the owner of the equipment so all parties are advised.

Initial safety checks shall include:

- that capacitors are discharged: this shall be done in a safe manner to avoid possibility of sparking
- that no live electrical components and wiring are exposed while charging, recovering or purging the system
- that there is continuity of earth bonding

The following checks shall be applied to installations using FLAMMABLE REFRIGERANTS:

- the actual REFRIGERANT CHARGE is in accordance

with the room size within which the refrigerant containing parts are installed;

- the ventilation machinery and outlets are operating adequately and are not obstructed;

- if an indirect refrigerating circuit is being used, the secondary circuit shall be checked for the presence of refrigerant;

- marking to the equipment continues to be visible and legible. Markings and signs that are illegible shall be corrected;

- refrigerating pipe or components are installed in a position where they are unlikely to be exposed to any substance which may corrode refrigerant containing components, unless the components are constructed of materials which are inherently resistant to being corroded or are suitably protected against being so corroded.

During repairs to sealed electrical components, the components shall be replaced. Replacement parts shall be in accordance with the manufacturer's specifications.

During repairs to intrinsically safe components, the components must be replaced. Replace components only with parts specified by the manufacturer. Other parts may result in the ignition of refrigerant in the atmosphere from a leak.

The unit should be inspected once a year by a qualified service technician.

#### A-Filters

Units are equipped with six 24 X 24 X 2" filters. Filters should be checked monthly and replaced when necessary with filters of like kind and size. Take note of air flow direction marking on filter frame when reinstalling filters. See FIGURE 48.

**NOTE** - Filters must be U.L.C. certified or equivalent for use in Canada.

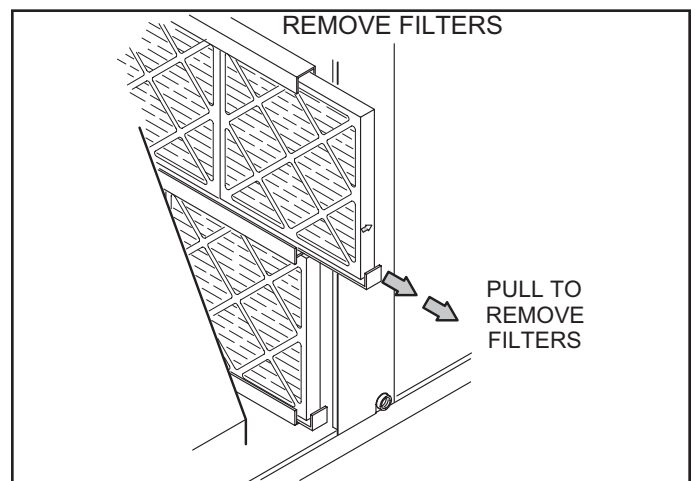


FIGURE 48

## ⚠ CAUTION

Label all wires prior to disconnection when servicing controls. Wiring errors can cause improper and dangerous operation. Verify proper operation after servicing.

## B-Lubrication

All motors are lubricated at the factory. No further lubrication is required.

Blower shaft bearings are prelubricated. For extended bearing life, relubricate at least once every two years with a lithium base grease, such as Alvania 3 (Shell Oil), Chevron BRB2 (Standard Oil) or Regal AFB2 (Texas Oil). Use a hand grease gun for relubrication. Add only enough grease to purge through the bearings so that a bead of grease appears at the seal lip contacts.

## C-Burners (Gas Units)

Periodically examine burner flames for proper appearance during the heating season. Before each heating season examine the burners for any deposits or blockage which may have occurred.

Clean burners as follows:

- 1 - Turn off both electrical power and gas supply to unit.
- 2 - Open burner compartment access panel.
- 3 - Remove screws securing burner assembly to burner support and remove assembly. See FIGURE 49. Clean as necessary.
- 4 - Locate the ignitor under the left burners. Check ignitor spark gap with appropriately sized twist drills or feeler gauges. See FIGURE 50.
- 5 - Check the alignment of the ignitor and the sensor as shown in FIGURE 51 and TABLE 24.
- 6 - Replace burners and screws securing burner.
- 7 - Replace access panel.
- 8 - Restore electrical power and gas supply. Follow lighting instructions attached to unit and use inspection port in access panel to check flame.

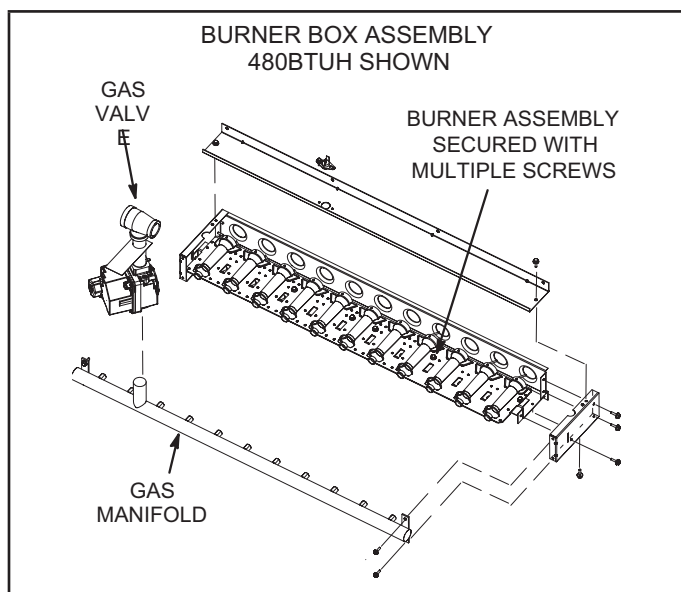


FIGURE 49

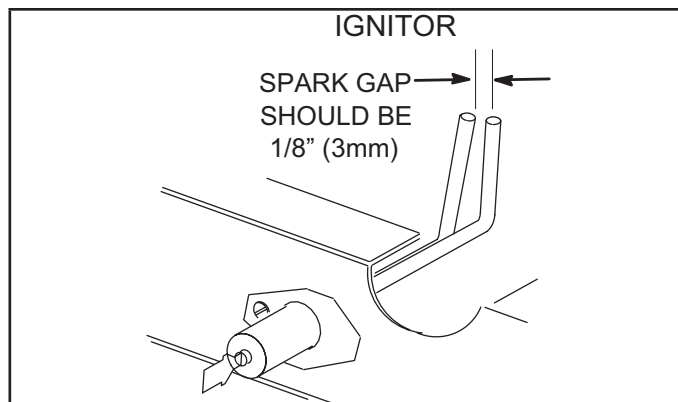


FIGURE 50

TABLE 24

Dimension	Unit Btuh Input	Length - in. (mm)	
		Ignitor	Sensor
A	260K	7-3/4 (197)	11 (279)
B	360K	5 (127)	5-1/2 (140)
C	480K	2-1/4 (57)	2-3/4 (70)

## ⚠ WARNING



Danger of explosion. Can cause injury or death. Do not overtighten main burner mounting screws. Snug tighten only.

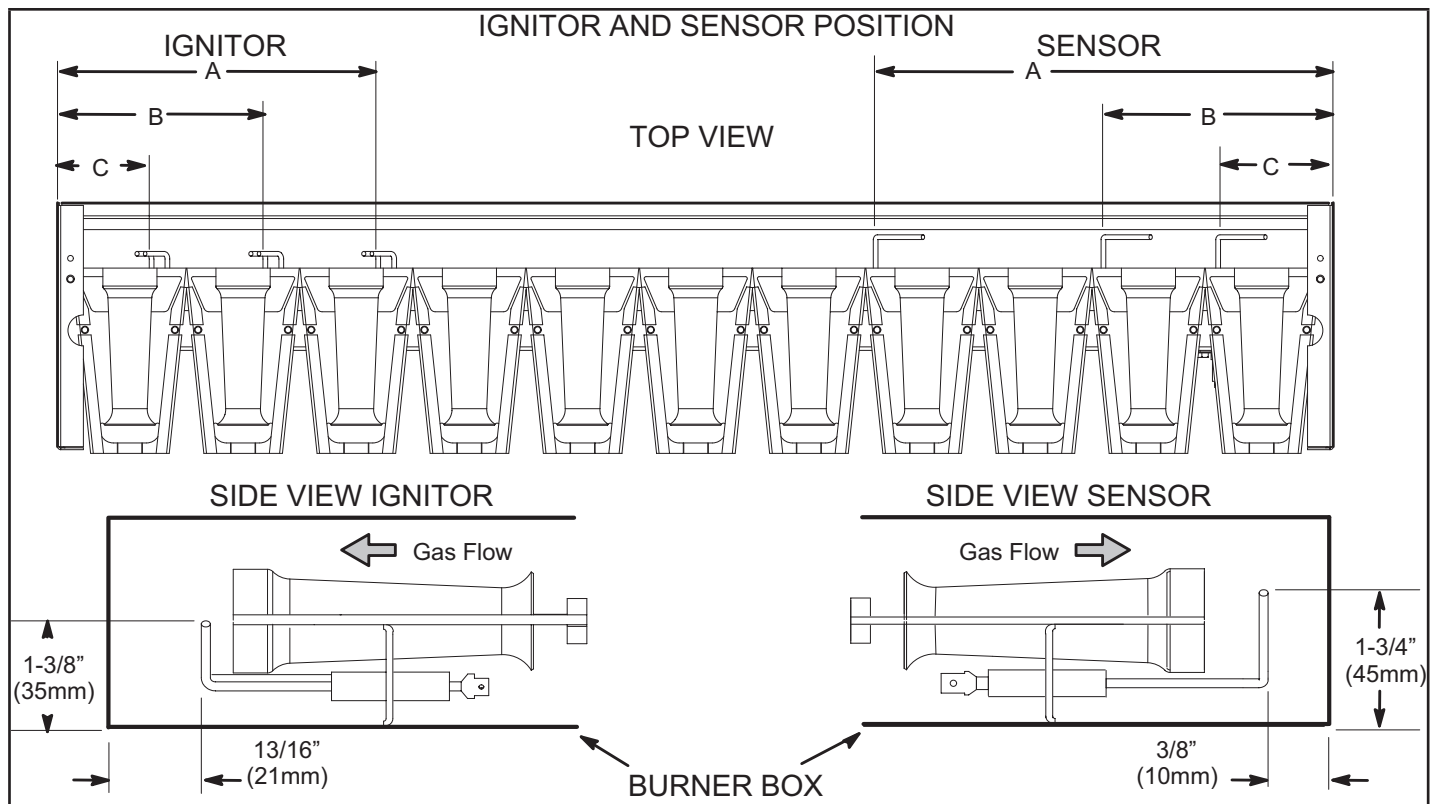
## D-Combustion Air Inducer (Gas Units)

A combustion air proving switch checks combustion air inducer operation before allowing power to the gas controller. Gas controller will not operate if inducer is obstructed. Under normal operating conditions, the combustion air inducer wheel should be checked and cleaned prior to the heating season. However, it should be examined periodically during the heating season to establish an

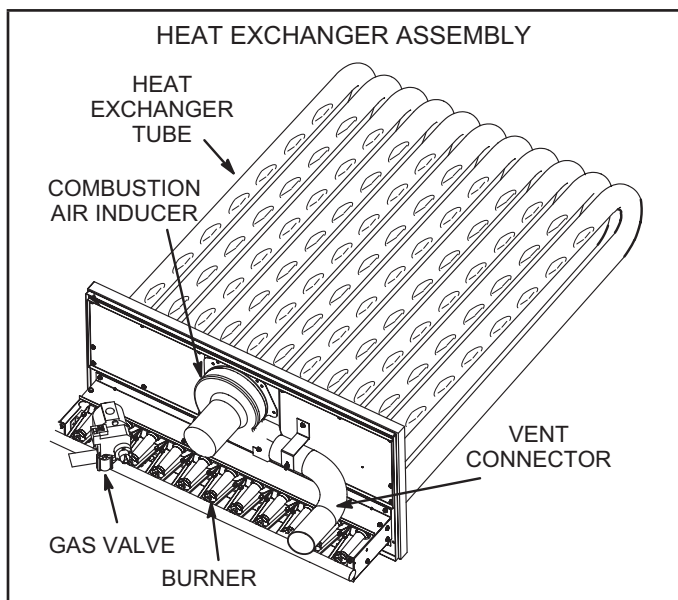
ideal cleaning schedule. With power supply disconnected, the condition of the inducer wheel can be determined by looking through the vent opening.

Clean combustion air inducer as follows:

- 1 - Shut off power supply and gas to unit.
- 2 - Disconnect pressure switch air tubing from combustion air inducer port.
- 3 - Remove and retain screws securing combustion air inducer to flue box. Remove and retain two screws from bracket supporting vent connector. See FIGURE 52.
- 4 - Clean inducer wheel blades with a small brush and wipe off any dust from housing. Clean accumulated dust from front of flue box cover.
- 5 - Return combustion air inducer motor and vent connector to original location and secure with retained screws. It is recommended that the combustion air inducer gasket be replaced during reassembly.
- 6 - Clean combustion air inlet louvers on heat access panel using a small brush.



**FIGURE 51**



**FIGURE 52**

**E-Flue Passageway and Flue Box (Gas Units)**

- 1 - Remove combustion air inducer assembly as described in section D.
- 2 - Remove flue box cover. Clean with a wire brush as required.
- 3 - Clean tubes with a wire brush.
- 4 - Reassemble the unit. The flue box cover gasket and combustion air inducer gasket should also be replaced during reassembly.

**F-Evaporator Coil**

Inspect and clean coil at beginning of each cooling season. Clean using mild detergent or commercial coil cleaner. Flush coil and condensate drain with water taking care not to get insulation, filters and return air ducts wet.

**G-Supply Air Blower Wheel**

Annually inspect supply air blower wheel for accumulated dirt or dust. Turn off power before attempting to remove access panel or to clean blower wheel.

**H-Condenser Coil**

Clean condenser coil annually with detergent or commercial coil cleaner and inspect monthly during the cooling season. Access panels are provided on front and back of condenser section.

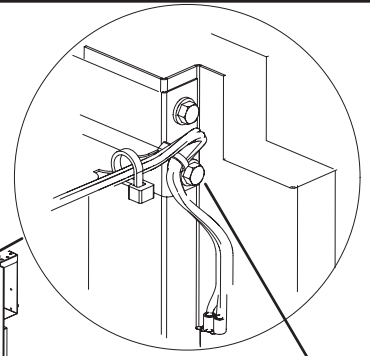
**I-Needlepoint Bipolar Ionizer**

The optional, brush-type ionizer produces positive and negative ions to clean air and reduce airborne contaminants. The ionizer was designed to be low maintenance. The device should be checked semi-annually to confirm the brushes are clean for maximum output. The ionizer is located behind the filters. See FIGURE 53.

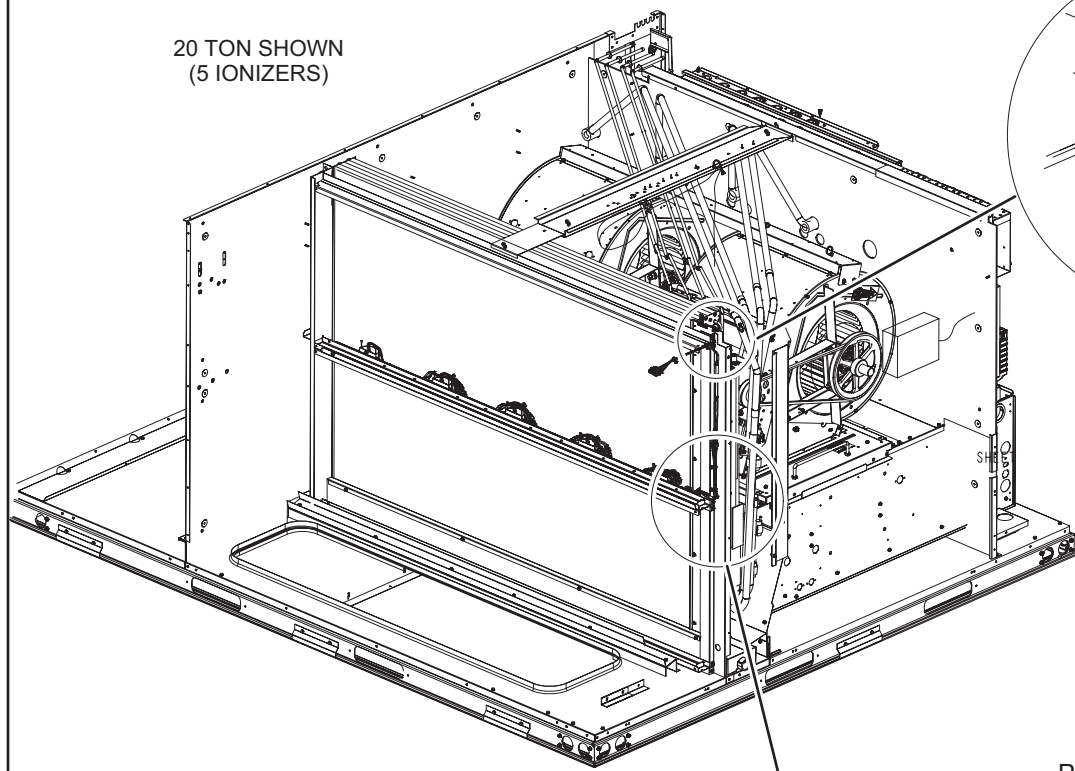
- 1 - Remove filters, screws securing the top and bottom of the upper filter bracket, and the wire ties the screws hold in place. See FIGURE 53.
- 2 - Disconnect the ionizer plug near the top of the filter rack.
- 3 - Pull ionizer out of unit and clean brushes.
- 4 - Replace ionizer, reconnect ionizer plug, and replace filters, screws, and wire ties.

INSTALL IONIZER - 156-300

20 TON SHOWN  
(5 IONIZERS)



REMOVE THE SCREW  
SECURING THE TOP  
OF THE UPPER FILTER  
RACK BRACKET



ONE EDGE  
PROTECTOR ON  
IONIZER BRACKET

REMOVE THE  
SCREW  
SECURING  
THE BOTTOM  
OF THE UPPER  
FILTER  
RACK BRACKET

EVAPORATOR  
COIL

TWO EDGE  
PROTECTORS ON  
FILTER RACK

IONIZER  
BRACKET

UPPER FILTER  
BRACKET  
U-CHANNEL

SLIDE IONIZER BRACKET  
BETWEEN UPPER AND LOWER  
FILTER BRACKET U-CHANNELS

LOWER FILTER  
BRACKET  
U-CHANNEL

FIGURE 53



### J-UVC Light (Optional)

When field-installed, use only UVC Light Kit assembly 106883-01 (21A94) with this appliance.

#### Factory-Installed UVC Light

When the UVC light is factory installed, the lamp is shipped in a foam sleeve. The lamp is attached to the UVC light assembly on the blower deck. Remove the lamp and install into the UVC light assembly as shown in steps 2 through 11 as follows.

#### Annual Lamp Replacement

## ⚠ WARNING

### Personal Burn Hazard.

Personal injury may result from hot lamps. During replacement, allow lamp to cool for 10 minutes before removing lamp from fixture.

The lamp should be replaced every 12 months, as UVC energy production diminishes over time.

- 1 - Obtain the correct model germicidal light replacement lamp 101087-02.
- 2 - Disconnect power to the rooftop unit before servicing the UVC kit.
- 3 - Open the blower access door.
- 4 - Disconnect the UVC cable quick connects (black/white).
- 5 - Remove and retain the (3) mounting screws securing the UVC assembly. Carefully remove the complete UVC assembly out through the blower access door. See FIGURE 55.

6 - Allow 10 minutes before touching the lamps. Then, carefully remove the lamp splash guards (and lamp for annual replacement) from each of the lamp holders. See FIGURE 54.

7 - Wear cotton gloves or use a cotton cloth when handling the new lamp. Gently but firmly push in the splash guards on each end of the lamp. Align and insert the lamp with splash guard into the lamp holders of the UVC assembly until each end clicks into place.

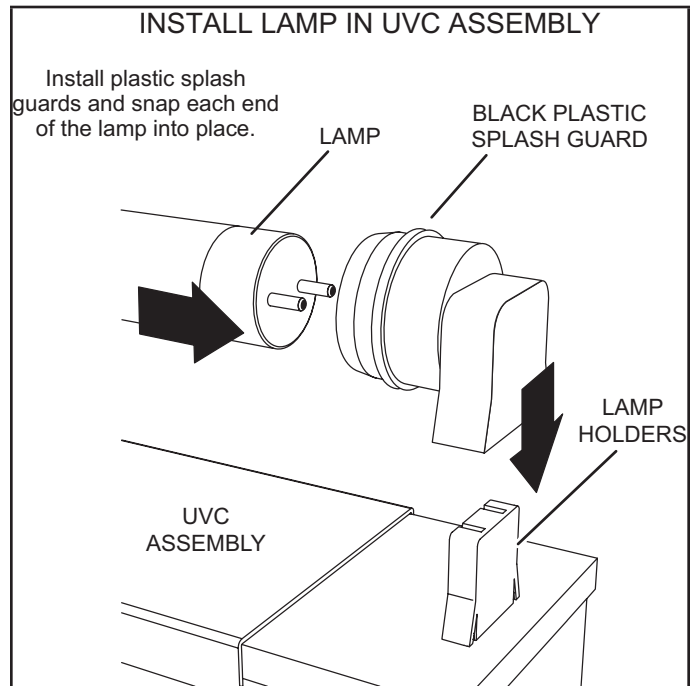


FIGURE 54

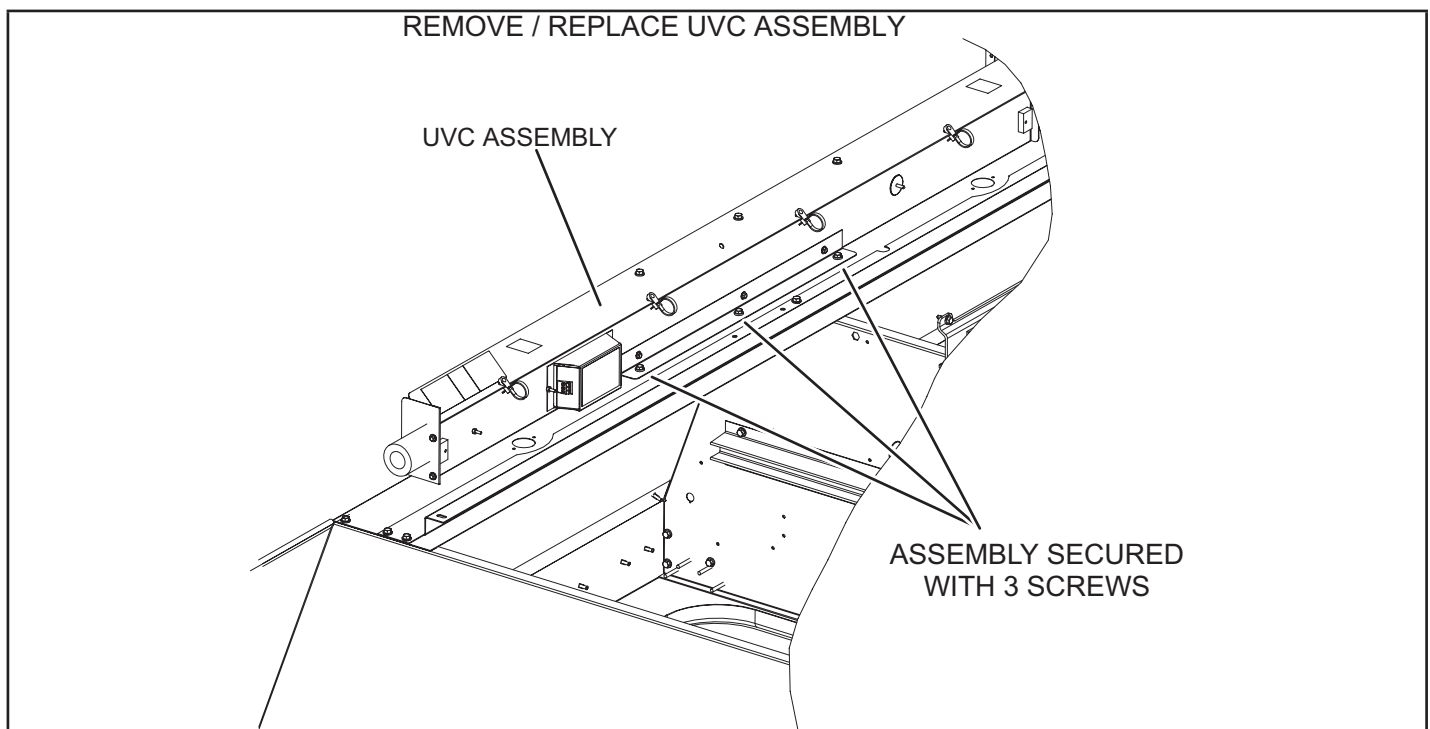


FIGURE 55

8 - Carefully place the UVC assembly on the blower deck. Line up the mounting holes on the UVC assembly with the mounting holes on the blower deck. Use the retained #10 screws to attach the UVC assembly in place.

9 - Close the blower access door.

10 - Reconnect power to the rooftop unit.

11 - Open the filter access door and look through the view port in the triangular sheet-metal panel to verify that the UVC light is on.

For all maintenance, contact a licensed HVAC technician. If UVC lamp does not come on:

1 - Check Power Wiring: Disconnect 1/4" QC (quick connects) of the UVC cable near the UVC assembly. With Power ON, use multimeter to test 110-230V at the 1/4"QC quick connects from the control panel.

2 - Check Lamp: Carefully remove the UVC assembly out of the rooftop unit. Use multimeter to test for continuity across each pair of pins at each end of the lamp.

3 - Check Lamp Installation: Make sure that lamp's pins snap properly into the lamp holder.

**Lamp Disposal**

Hg-Lamp Contains Mercury - Manage in accordance with local, state and federal disposal laws. Refer to [www.lamprecycle.org](http://www.lamprecycle.org).

Proper Clean-up Technique in Case of Lamp Breakage  
Wear protective gloves, eye wear and mask.

Sweep the broken glass and debris into a plastic bag, seal the bag, and dispose of properly. Contact your local waste management office for proper disposal.

Do not use a vacuum cleaner. Do not incinerate.

**Maintenance**

- For all maintenance, contact a qualified HVAC technician.
- Read the maintenance instructions before opening unit panels.
- Unintended use of the unit or damage to the unit housing may result in the escape of dangerous UVC radiation. UVC radiation may, even in small doses, cause harm to the eyes and skin.
- Do not operate units that are obviously damaged.
- Do not discard the triangular UVC light shield or any barriers with an ultraviolet radiation symbol.
- Do not override the door interlock switch that interrupts power to the UVC light.
- Do not operate the UVC light outside of the unit.

**M-Replacement Fuses**

See the following tables for the proper replacement fuse sizes.

ELECTRIC HEAT REPLACEMENT FUSES				
	Electric Heat	Qty.	Rating	
			Amp	Volt
1	E1EH0050N-1P	2	30	250
2	T1/E1EH0075AN1Y	3	25	250
3	E1EH0100N-1P	4	30	250
4	T1/E1EH0150AN1Y	3	50	250
5	T1/E1EH0225AN1Y	6	45	250
6	T1/E1EH0300N-1Y	6	60	250
7	E2EH0300N-1Y	6	60	250
8	K1EH0050A-1P	2	30	250
9	T1/E1EH0075AN1P	2	40	250
10	T1EH0100A-1P	4	30	250
11	T1/E1EH0150AN1P	4	40	250
12	T1/E1EH0225AN1P	6	40	250
13	T1/E1EH0075AN1J	3	15	600
14	T1/E1EH0150AN1J	3	20	600
15	T1/E1EH0225AN1J	3	30	600
16	T1/E1EH0300N-1J	3	40	600
17	T1/E1EH0075AN1G	3	15	600
18	T1/E1EH0150AN1G	3	25	600
19	T1/E1EH0225AN1G	3	35	600
20	T1/E1EH0300N-1G	3	50	600
21	K1/E1EH0057AN1M	3	15	600
22	K1/E1EH0115AN1M	3	20	600
23	K1EH0172AN1M	3	30	600
24	E1EH0172N-1M	3	30	600
25	K1/E1EH0230N-1M	3	40	600



UNIT REPLACEMENT FUSES										
LGM/LCM156U										
Unit Voltage			208V - 3 Ph		240V - 3 Ph		480V - 3Ph		600V - 3 Ph	
Power Exhaust Option			W / P.E.	W / O P.E.	W / P.E.	W / O P.E.	W / P.E.	W / O P.E.	W / P.E.	W / O P.E.
Diagram Key	Class	Blower HP	Amps							
F10	CC	ALL	30 A	30 A	30 A	30 A	12 A	12 A	12 A	12 A
F61	J	ALL	For F61 Fuse, see MOP Value on nameplate.							
F57	CC	ALL	-	-	-	-	7.5 A	7.5 A	10 A	10 A
F58	CC	ALL	-	-	-	-	7.5 A	7.5 A	10 A	10 A

<sup>1</sup> When SCCR is installed, F4 fuse is Class J.

<sup>2</sup> Fuse F61 is only used on units with SCCR installed.

LGM/LCM180U										
Unit Voltage			208V - 3 Ph		240V - 3 Ph		480V - 3Ph		600V - 3 Ph	
Power Exhaust Option			W / P.E.	W / O P.E.	W / P.E.	W / O P.E.	W / P.E.	W / O P.E.	W / P.E.	W / O P.E.
Diagram Key	Class	Blower HP	Amps							
F10	CC	ALL	30 A	30 A	30 A	30 A	12 A	12 A	12 A	12 A
F61	J	ALL	For F61 Fuse, see MOP Value on nameplate.							
F57	CC	ALL	-	-	-	-	7.5 A	7.5 A	10 A	10 A
F58	CC	ALL	-	-	-	-	7.5 A	7.5 A	10 A	10 A

<sup>1</sup> When SCCR is installed, F4 fuse is Class J.

<sup>2</sup> Fuse F61 is only used on units with SCCR installed.

LGM/LCM210U										
Unit Voltage			208V - 3 Ph		240V - 3 Ph		480V - 3Ph		600V - 3 Ph	
Power Exhaust Option			W / P.E.	W / O P.E.	W / P.E.	W / O P.E.	W / P.E.	W / O P.E.	W / P.E.	W / O P.E.
Diagram Key	Class	Blower HP	Amps							
F10	CC	ALL	30 A	30 A	30 A	30 A	12 A	12 A	12 A	12 A
F61	J	ALL	For F61 Fuse, see MOP Value on nameplate.							
F57	CC	ALL	-	-	-	-	7.5 A	7.5 A	10 A	10 A
F58	CC	ALL	-	-	-	-	7.5 A	7.5 A	10 A	10 A

<sup>1</sup> When SCCR is installed, F4 fuse is Class J.

<sup>2</sup> Fuse F61 is only used on units with SCCR installed.

LGM/LCM240U										
Unit Voltage			208V - 3 Ph		240V - 3 Ph		480V - 3Ph		600V - 3 Ph	
Power Exhaust Option			W / P.E.	W / O P.E.	W / P.E.	W / O P.E.	W / P.E.	W / O P.E.	W / P.E.	W / O P.E.
Diagram Key	Class	Blower HP	Amps							
F10	CC	ALL	30 A	30 A	30 A	30 A	12 A	12 A	12 A	12 A
F61	J	ALL	For F61 Fuse, see MOP Value on nameplate.							
F57	CC	ALL	-	-	-	-	7.5 A	7.5 A	10 A	10 A
F58	CC	ALL	-	-	-	-	7.5 A	7.5 A	10 A	10 A

<sup>1</sup> When SCCR is installed, F4 fuse is Class J.

<sup>2</sup> Fuse F61 is only used on units with SCCR installed.

LGM/LCM300U										
Unit Voltage			208V - 3 Ph		240V - 3 Ph		480V - 3Ph		600V - 3 Ph	
Power Exhaust Option			W / P.E.	W / O P.E.	W / P.E.	W / O P.E.	W / P.E.	W / O P.E.	W / P.E.	W / O P.E.
Diagram Key	Class	Blower HP	Amps							
F10	CC	ALL	30 A	30 A	30 A	30 A	12 A	12 A	12 A	12 A
F61	J	ALL	For F61 Fuse, see MOP Value on nameplate.							
F57	CC	ALL	-	-	-	-	7.5 A	7.5 A	10 A	10 A
F58	CC	ALL	-	-	-	-	7.5 A	7.5 A	10 A	10 A

<sup>1</sup> When SCCR is installed, F4 fuse is Class J.

<sup>2</sup> Fuse F61 is only used on units with SCCR installed.

**TABLE 25 - 581025-01**

LGM/LCM 156U, 180U, 210U, 240U, 300U Staged							
Parameter	Factory Setting					Field Setting	Description
	156U	180U	210U	240U	300U		
<i>NOTE - Any changes to Smoke CFM setting must be adjusted before the other CFM settings. Use SETTINGS &gt; RTU OPTIONS &gt; EDIT PARAMETERS</i>							
12	5200 CFM	6000 CFM	7000 CFM	8000 CFM	10000 CFM	CFM	Blower CFM during smoke detection.
<b>SETUP &gt; TEST &amp; BALANCE (can also use SETTINGS &gt; RTU OPTIONS &gt; BLOWER &gt; SPEEDS)</b>							
17	1150 CFM	1325 CFM	1550 CFM	1750 CFM	2200 CFM	CFM	Blower CFM during COOLIN LOW operation.
17	4550 CFM	5250 CFM	6125 CFM	7000 CFM	8750 CFM	CFM	Blower CFM during COOLING HIGH operation.
13	5200 CFM	6000 CFM	7000 CFM	8000 CFM	10000 CFM	CFM	Blower CFM during Heating operation.
18	1150 CFM	1325 CFM	1550 CFM	1750 CFM	2200 CFM	CFM	Blower CFM during ventilation.
<b>SETUP &gt; TEST &amp; BALANCE (can also use SETTINGS &gt; RTU OPTIONS &gt; DAMPER)</b>							
9	0%	0%	0%	0%	0%	%	Damper min. position during LOW blower operation.
132	0%	0%	0%	0%	0%	%	Damper min. position during HIGH blower operation.
215	50%	50%	50%	50%	50%	%	Min. damper % for stg 1 power exhaust operation.
<b>SETTINGS &gt; RTU OPTIONS &gt; EDIT PARAMETERS</b>							
29	101%	101%	101%	101%	101%	%Open	
219	75%	75%	75%	75%	75%	%	Min. damper % for stg 2 power exhaust operation.
216	10%	10%	10%	10%	10%	%	Deadband % for stage 1 power exhaust operation.
220	10%	10%	10%	10%	10%	%	Deadband % for stage 2 power exhaust operation.
224	100	100	100	100	100	Sec	Stage 1 power exhaust off-delay in seconds.
30	70%	70%	70%	70%	70%	%Speed	Minimum blower speed % for stage 2 power exhaust operation.

**TABLE 26 - 581026-01**

Parameter	Factory Setting	Field Setting	Description
<b>Use SETTINGS &gt; RTU OPTIONS &gt; EDIT PARAMETERS</b>			
386	1	W.C.	Supply static pressure setpoint during smoke operation.
<b>SETUP &gt; TEST &amp; BALANCE &gt; (can also use SETTINGS &gt; RTU OPTIONS &gt; BLOWER &gt; SPEEDS)</b>			
	1	W.C.	Supply static pressure setpoint
<b>SETUP &gt; TEST &amp; BALANCE (can also use SETTINGS &gt; RTU OPTIONS &gt; DAMPER) (Optional)</b>			
132	0%	%	Damper min. position during blower operation.
215	50%	%	Min. damper % for stage 1 power exhaust operation.
219	75%	%	Min. damper % for stage 2 power exhaust operation.
217	0.05	W.C.	Pressure setpoint for stage 1 power exhaust operation.
221	0.10	W.C.	Pressure setpoint for stage 2 power exhaust operation.
29	101%	%Open	Damper minimum position during G blower operation. (Setting parameter 29 to "101" disables parameter 29 and passes control to parameter 9 or 132)

## Factory Unit Controller Settings

Use the mobile service app to adjust parameters; menu paths are shown in each table. Refer to the Unit Controller manual provided with each unit.

TABLE 27 through TABLE 29 show factory settings (in degrees, % of fan CFM, etc.). Record adjusted settings on the label located inside the compressor access panel.

When field installing optional kits and accessories, the Unit Controller must be configured to identify the option before it will function. Refer to FIGURE 56 and FIGURE 57 to determine whether the Unit Controller configuration I.D. must change. To configure the option, use MAIN MENU > SETUP > INSTALL menu path. Press SAVE until CONFIGURATION ID 1 or 2 appears depending on the option installed. Change the appropriate character in the configuration I.D. For example, when an economizer is installed using a single enthalpy sensor, change configuration I.D. 1, the second character, to "S".

**TABLE 27 - 581038-01**

Units With BACnet Module Settings	
RTU Menu > Network Integration > Network Setup Wizard > BACnet MS/TP > See BACnet MAC Address	
BACNET MAC ADDRESS:	
Units With Room Sensor, CPC/LSE Gateway Settings	
RTU Menu > Network Integration > Network Setup Wizard > SBUS > Set SBUS Address	
LCONN ADDRESS:	

**TABLE 28 - 581024-01**

Units With Hot Gas Reheat			
RTU Menu > Settings "RTU Options" > Dehumidifier			
Parameter	Factory Setting	Field Setting	Description
105	7		Factory Setting 7: Reheat mode enabled without prerequisite conditions. Controlled by RH sensor (A91) connected to input A55_P298_5 and set point set at parameter 106 (default 60%).

**TABLE 29 - 581037-01**

Units With LonTalk Settings	
Use menu RTU Menu > Network Integration > Network Setup Wizard > Set "LONTALK"	

## Decommissioning

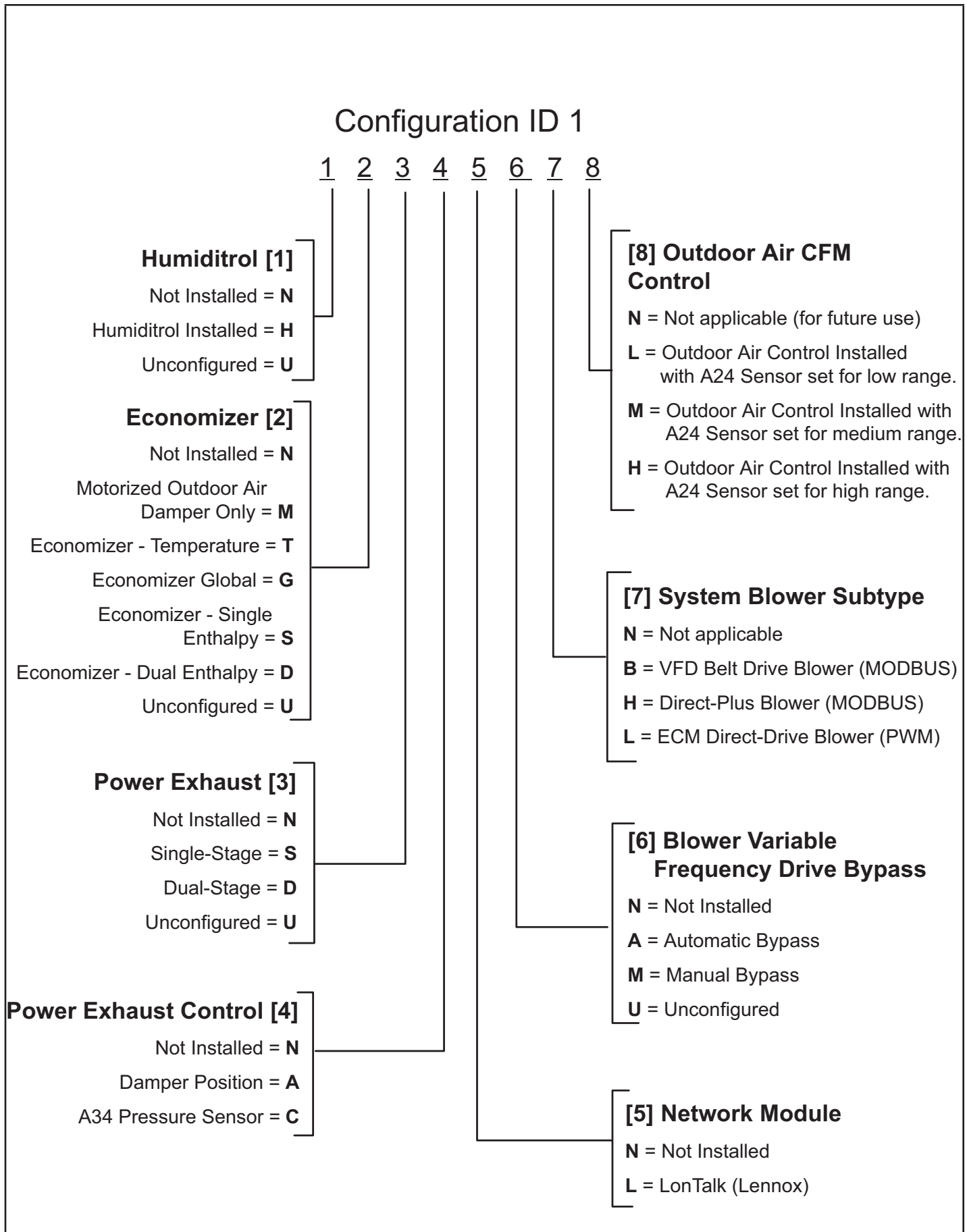
Before carrying out this procedure, it is essential that the technician is completely familiar with the equipment and all its detail. It is recommended good practice that all refrigerants are recovered safely.

Prior to the task being carried out, an oil and refrigerant sample shall be taken in case analysis is required prior to re-use of recovered refrigerant. It is essential that electrical power is available before starting decommissioning.

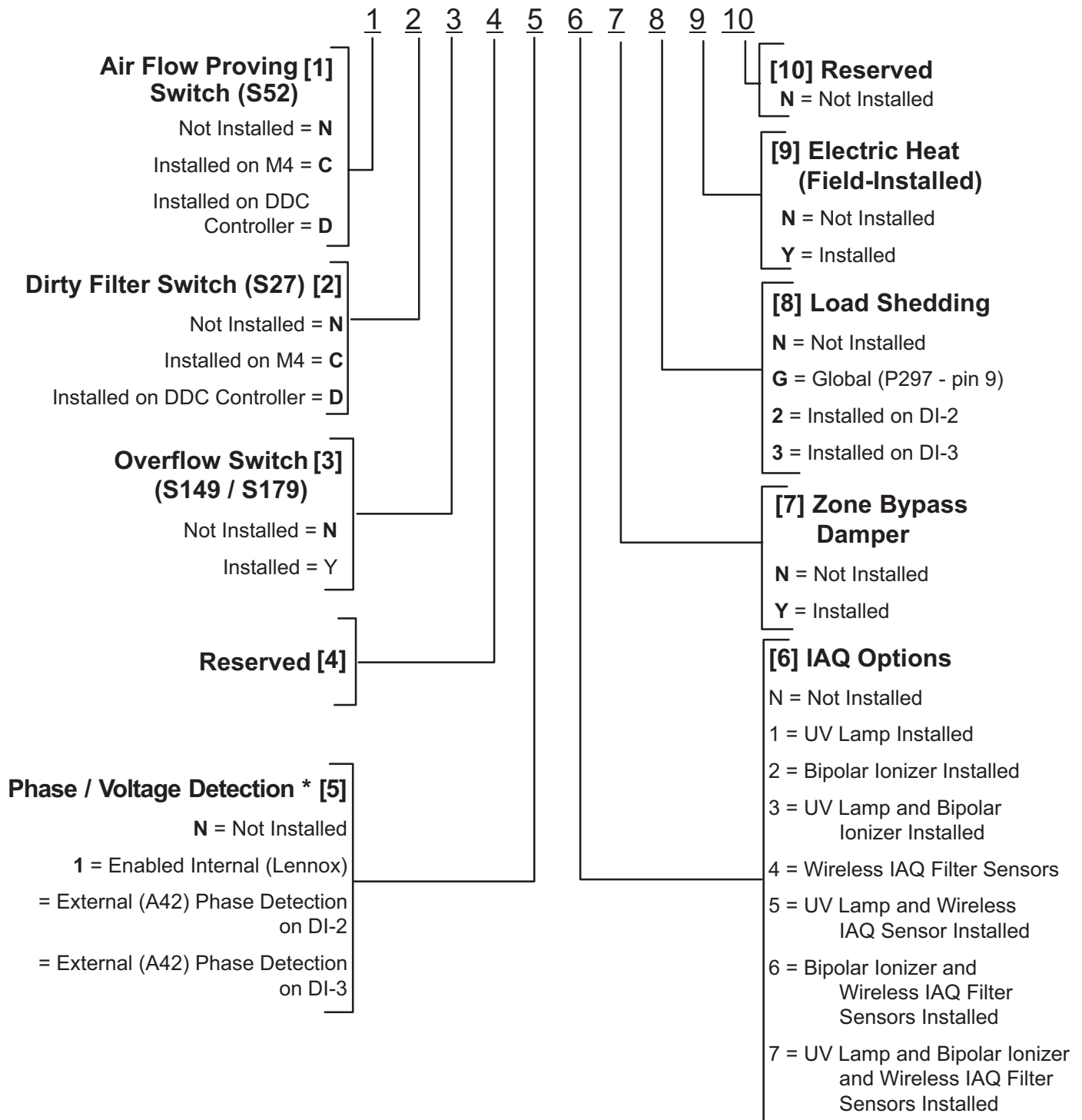
- a) Become familiar with the equipment and its operation.
- b) Isolate system electrically.
- c) Before attempting the procedure, ensure that:
  - mechanical handling equipment is available, if required, for handling refrigerant cylinders;
  - all personal protective equipment is available and being used correctly;
  - the recovery process is supervised at all times by a competent person;
  - recovery equipment and cylinders conform to the appropriate standards.
- d) Pump down refrigerant system, if possible.
- e) If a vacuum is not possible, make a manifold so that refrigerant can be removed from various parts of the system.
- f) Make sure that cylinder is situated on the scales before recovery takes place.
- g) Start the recovery machine and operate in accordance with instructions.
- h) Do not overfill cylinders (no more than 80% volume liquid charge).
- i) Do not exceed the maximum working pressure of the cylinder, even temporarily.
- j) When the cylinders have been filled correctly and the process completed, make sure that the cylinders and the equipment are removed from site promptly and all isolation valves on the equipment are closed off.
- k) Recovered refrigerant shall not be charged into another REFRIGERATING SYSTEM unless it has been cleaned and checked.

## IMPORTANT

Equipment shall be labelled stating that it has been decommissioned and emptied of refrigerant. The label shall be signed and dated. Ensure that there are labels on the equipment that state the flammability of the refrigerant used.



## Configuration ID 2



**FIGURE 57**

## START-UP REPORT

Job Name: \_\_\_\_\_  
 Store No. \_\_\_\_\_ Start-Up Date: \_\_\_\_\_  
 Address: \_\_\_\_\_  
 City: \_\_\_\_\_ State: \_\_\_\_\_  
 Start-Up Contractor: \_\_\_\_\_  
 Technician: \_\_\_\_\_  
 Model No.: \_\_\_\_\_  
 Serial No.: \_\_\_\_\_  
 RTU No.: \_\_\_\_\_ Catalog No.: \_\_\_\_\_

Inspections and Checks			
Damage?	Yes	No	R454B <input type="checkbox"/>
If yes, reported to: _____			
Verify factory and field-installed accessories.			
Check electrical connections. Tighten if necessary.			
Supply voltage: L1-L2 _____ L1-L3 _____ L2-L3 _____			
If unit contains a 208-230/240 volt transformer:			
Check primary transformer tap <input type="checkbox"/>			
Transformer secondary voltage: _____			

Cooling Checks												
Compressor Rotation <input type="checkbox"/> Ambient Temp. _____ Return Air Temp. _____ Supply Air Temp. _____												
	Compressor Amps			Compressor Volts			Pressures		Condenser Fan Amps			CC Heater Amps
	L1	L2	L3	L1-L2	L1-L3	L2-L3	Disch.	Suct.	L1	L2	L3	L1
1												
2												
3												
4												

Blower Checks			
Pulley/Belt Alignment <input type="checkbox"/>	Blower Rotation <input type="checkbox"/>		
Set Screws Tight <input type="checkbox"/>	Belt Tension <input type="checkbox"/>		
Nameplate Amps: _____		Volts: _____	
Motor	Amps	Volts	
	L1 _____	L1-L2 _____	
	L2 _____	L1-L3 _____	
	L3 _____	L2-L3 _____	

Heating Checks - Electric							
Return Air Temp.: _____ Supply Air Temp.: _____							
Limits Operate: <input type="checkbox"/>							
	Amps						
	L1	L2	L3		L1	L2	L3
1				10			
2				11			
3				12			
4				13			
5				14			
6				15			
7				16			
8				17			
9				18			

Heating Checks - Gas		
Fuel type: Nat. <input type="checkbox"/> LP <input type="checkbox"/> Inlet Pressure: _____ in. w.c.		
Return Air Temp.: _____ Supply Air Temp.: _____		
Altitude: _____ Primary Limits Operate: <input type="checkbox"/>		
CO <sub>2</sub> %: _____		
Gas Valve	Manifold Pressure	
	Low Fire	High Fire
GV1		
GV2		

Accessory Checks	
Power Exhaust Amps	
1 _____	2 _____ None <input type="checkbox"/>
Economizer Operation	
Min. Pos. <input type="checkbox"/>	Motor travel full open/close <input type="checkbox"/>

Control Type