

LGT

ENLIGHT ROOFTOP UNITS

High Efficiency | Lennox® CORE Controller | Environ™ Coil | **R-454B** | 60Hz

COMMERCIAL
PRODUCT SPECIFICATIONS (EHB)



13 to 25 Tons

Net Cooling Capacity | 148,000 to 270,000 Btuh
Gas Input Heat Capacity | 169,000 to 480,000 Btuh

ENLIGHT



SMARTWIRE™ SYSTEM



ASHRAE
Standard
90.1

MODEL NUMBER IDENTIFICATION

LGT240 H5 M S 1 Y

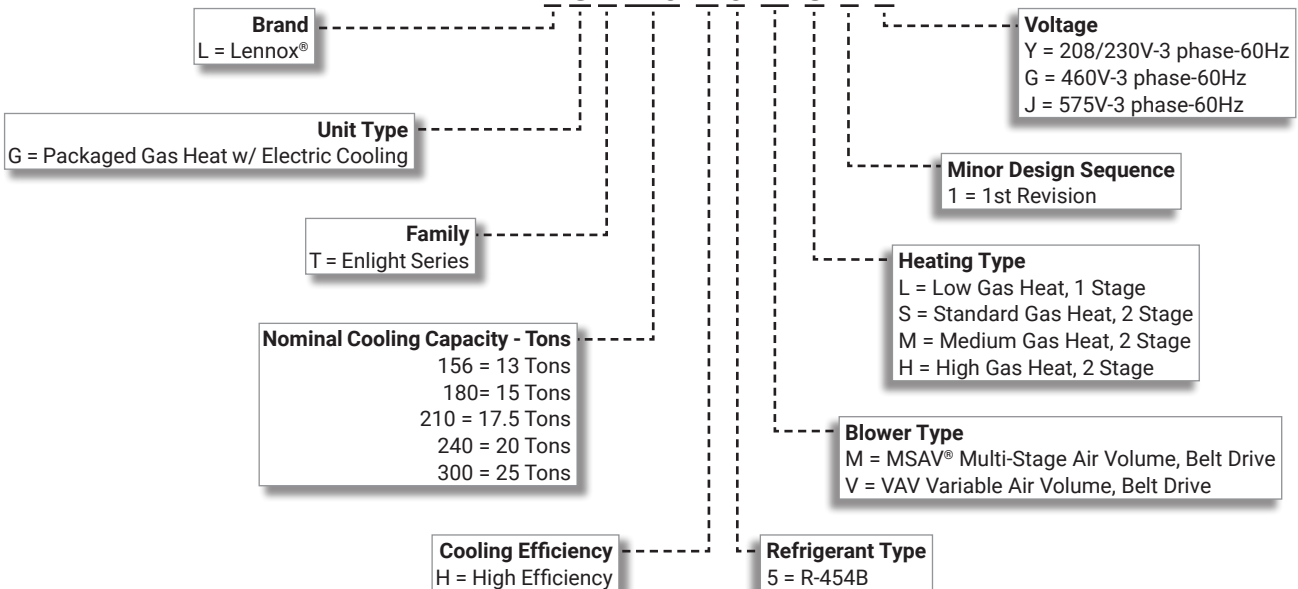

FEATURE HIGHLIGHTS

Enlight rooftop units featuring the Lennox® CORE Control System create a bright future through a highly energy-efficient and environmentally sustainable design. Comprehensive configurations meet a wide range of applications, making it the most flexible product line Lennox has to offer.

1. Heat Exchanger
2. Inshot Burners
3. Scroll Compressors
4. Thermal Expansion Valves
5. Filter/Driers
6. Environ™ Coil System
7. Outdoor Coil Fan Motors
8. Heavy Gauge Steel Cabinet
9. Hinged Access Panels
10. Air Filters
11. MSAV® Multi-Stage Air Volume or VAV Variable Air Volume, Blower
12. Disconnect Switch (option)
13. Lennox® CORE Control System
14. Economizer (option)
15. Downflow Barometric Relief Dampers (option)
16. Power Exhaust Fans (option)

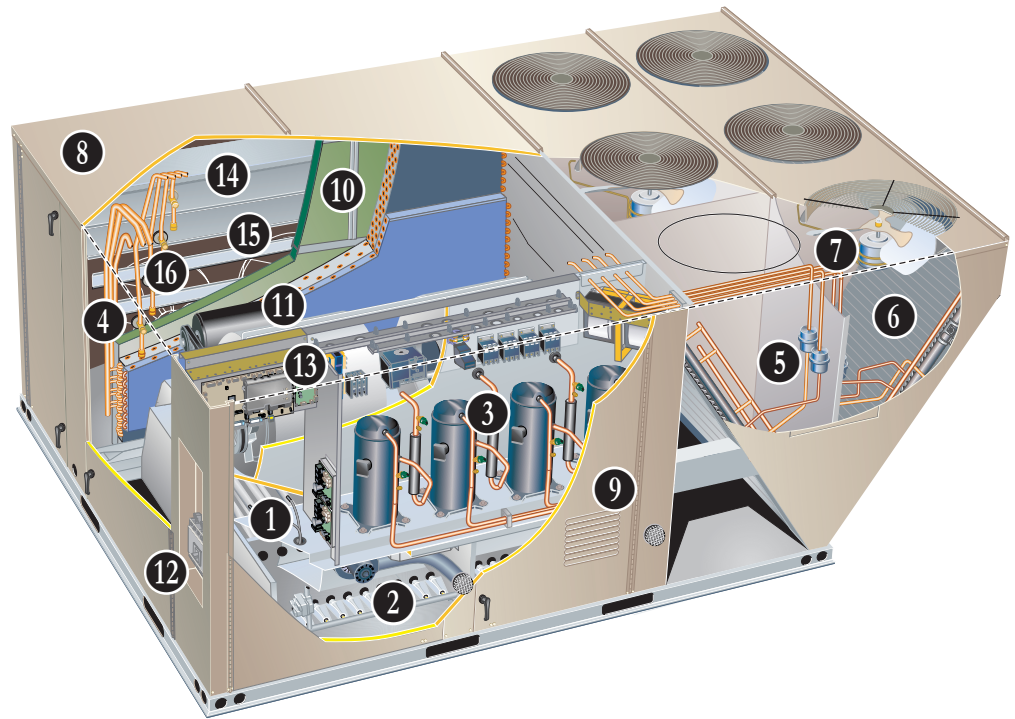

CONTENTS

Approvals And Warranty	3
Blower Data	48
Control System	9
Dimensions	57
- 156	57
- 180 210	58
- 240 300	59
- Accessories	60
Electrical Accessories	54
Electrical Data	51
Features And Benefits	3
High Altitude Derate	39
Humiditrol® Dehumidification System Option	13
Humiditrol® Dehumidification System Ratings	45
Installation Clearances	55
Model Number Identification	1
Optional Conventional Temperature Control Systems	16
Options / Accessories	30
Outdoor Sound Data	55
Ratings	40
Sequence Of Operation	18
Specifications	34
- 13 Ton	34
- 15 Ton	35
- 17.5 Ton	36
- 20 Ton	37
- 25 Ton	38
- Gas Heat	39
Weight Data	56
- Options / Accessories	56
- Unit	56

APPROVALS AND WARRANTY

APPROVALS

- AHRI Standard 340/360-2023 certified
- ETL and CSA listed
- Unit and components ETL, NEC, and CEC bonded for grounding to meet safety standards for servicing
- All models are ASHRAE 90.1 energy efficiency compliant and meet or exceed requirements of Section 6.8
- All models meet DOE 2023 energy efficiency standards and UL 60335-2-40 Refrigerant Detector Requirements
- All models have HCAI (formerly OSHPD) OSP and Special Seismic Certification ([Number: OSP-0596](#)), and meet 2021 International Building Code (IBC), 2022 California Building Code (CBC) ASCE 7, and ICC-ES AC156
- MSAV® models meet California Code of Regulations, Title 24 and ASHRAE 90.1 Section 6.4.3.10 requirements for staged airflow
- ISO 9001 Registered Manufacturing Quality System

WARRANTY

- Aluminized Heat Exchanger - Limited ten years
- Stainless Steel Heat Exchanger (optional) - Limited fifteen years
- Compressors - Limited five years
- Environ™ Coil System - Limited three years
- Lennox® CORE Unit Controller - Limited three years
- Variable Frequency Drive (VFD) - Limited five years
- High Performance Economizers (optional) - Limited five years
- All other covered components - Limited one year

FEATURES AND BENEFITS

HEATING SYSTEM

1 Heat Exchanger

- Tubular construction, aluminized steel
- Life-cycle tested

NOTE - Optional Stainless Steel Heat Exchanger is required if mixed air temperature is below 45°F.

2

- Aluminized steel inshot burners
- Direct spark ignition
- Electronic flame sensor
- Combustion air inducer
- Redundant automatic dual stage gas valve with manual shut-off

Electronic Pilot Ignition

- Electronic spark igniter provides positive direct ignition of burners on each operating cycle
- Permits main gas valve to stay open only when the burners are proven to be lit
- If loss of flame occurs, gas valve closes, shutting off the gas to the burners
- LED indicates status and aids in troubleshooting
- Factory installed in the control section

Limit Controls

- Redundant limit controls with fixed temperature setting
- Protects heat exchanger and other components from overheating

Safety Switches

- Flame roll-out switch
- Flame sensor
- Combustion air inducer proving switch
- Protects system operation

Required Selections

Gas Input Choice - Order one:

- Low Gas Heat, 1 Stage (169,000 Btuh)
- Standard Gas Heat, 2 Stage (85,000/260,000 Btuh)
- Medium Gas Heat, 2 Stage (117,000/360,000 Btuh)
- High Gas Heat, 2 Stage (156,000/480,000 Btuh)

NOTE – Two-stage heat models can be operated with four stages of gas heating when controlled in either zone sensor, Discharge Air Control, or fresh air tempering mode on the Lennox CORE® Control System. See Gas Heating Specifications table.

Options/Accessories

Factory Installed

Stainless Steel Heat Exchanger

- Required if mixed air temperature is below 45°F

FEATURES AND BENEFITS

HEATING SYSTEM (continued)

Options/Accessories

Field Installed

Bottom Gas Piping Kit

- Allows bottom gas entry

Combustion Air Intake Extensions

- Recommended for use with existing flue extension kits in areas where high snow areas can block intake air
- Order two kits

Low Temperature Vestibule Heater

- Electric heater automatically controls minimum temperature in gas burner compartment when temperature is below -40°F
- CSA certified to allow operation of unit down to -60°F

LPG/Propane Kits

- Conversion kit to field change over units from Natural Gas to LPG/Propane
- Order two kits

Vertical Vent Extension Kit

- Use to exhaust flue gases vertically above unit
- Required when unit vent is too close to fresh air intakes per building codes
- Also prevents ice formation on intake louvers
- Kit contains vent transition, vent tee, drain cap, and installation hardware
- Order two kits.

NOTE - Straight vent pipes (4 in. B-Vent) and caps are not furnished and must be field supplied. Refer to kit instructions for additional information.

COOLING SYSTEM

- Designed to maximize sensible and latent cooling performance at design conditions
- System can operate from 0°F to 125°F without any additional controls

R-454B Refrigerant

- Low GWP (Global Warming Potential)
- Zero ODP (Ozone Depletion Potential)
- Low Toxicity/Lower Flammability - A2L
- Unit is factory pre-charged

3 Compressor System

- Scroll compressor on all models for high performance, reliability, and quiet operation
- Resiliently mounted on rubber grommets for quiet operation

Compressor Crankcase Heaters

- Protects against refrigerant migration that can occur during low ambient operation

4 Thermal Expansion Valves

- Ensures optimal performance throughout the application range
- Removable element head

5 Filter/Driers

- High capacity filter/drier protects the system from dirt and moisture

High Pressure Switches

- Protects the compressor from overload conditions such as dirty condenser coils, blocked refrigerant flow or loss of outdoor fan operation

Low Pressure Switches

- Protects the compressors from low pressure conditions such as low refrigerant charge or low/no airflow

Indoor Coil Freeze Protection

- Protects the evaporator coil from damaging ice build-up due to conditions such as low/no airflow or low refrigerant charge

6 Condenser Coil - Environ™ Coil System

- Lightweight, all aluminum brazed fin construction
- Constructed of three components
 - A flat extrusion tube
 - Fins in-between the flat extrusion tube
 - Two refrigerant manifolds

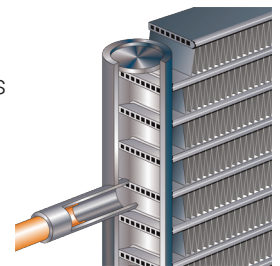

Environ™ Coil System Features:

- Improved heat transfer performance due to high primary surface area (flat tubes) versus secondary surface (fins)
- Smaller internal volume (reduced refrigerant charge)
- High durability
- All aluminum construction
- Fewer brazed joints
- Compact design
- Reduced unit weight
- Easy maintenance/cleaning
- Mounting brackets with rubber inserts secure coil to unit providing vibration dampening and corrosion protection
- Angled cabinet design protects coil from damage

Evaporator Coil

- Copper tube construction
- Enhanced rippled-edge aluminum fins
- Flared shoulder tubing connections
- Silver soldered construction
- Factory leak tested
- Cross-row circuiting with rifled tubing
- Full-face, intertwined coil construction

Antimicrobial Condensate Drain Pan

- Composite pan, sloped to meet drainage requirements per ASHRAE 62.1
- Antimicrobial additive prevents growth of mold and mildew, which improves indoor air quality and reduces drain line blockage
- Side or bottom drain connections

FEATURES AND BENEFITS

COOLING SYSTEM (continued)

- 7** **Outdoor Coil Fan Motors**
- (1) ECM and (2) PSC (156 models)
 - (2) ECM and (2) PSC (180 and 210 models)
 - (2) ECM and (4) PSC (240 and 300 models)
 - Thermal overload protected
 - Fan speed is directly controlled by the Lennox® CORE Unit Controller
 - Totally enclosed
 - Permanently lubricated ball bearings
 - Shaft up
 - Wire basket mount

Outdoor Coil Fans

- PVC coated fan guard furnished

Required Selections

Cooling Capacity

- Specify nominal cooling capacity

Options/Accessories

Factory or Field Installed

Drain Pan Overflow Switch

- Monitors condensate level in drain pan
- Shuts down unit if drain becomes clogged

Field Installed

Condensate Drain Trap

- Available in copper or PVC

LOW GWP REFRIGERANT DETECTION SYSTEM (RDS)

- Complies with UL 60335-2-40 approved standard
- Required for all systems using R-454B refrigerant
- Factory installed on all units
- Consists of a refrigerant detection sensor(s) and a mitigation control
- Ensures safe operation for systems equipped with R-454B refrigerant
- Sensor(s) monitors indoor coil area for R-454B refrigerant
- If R-454B refrigerant is detected the refrigerant detection system will prevent compressor and heating operation until R-454B refrigerant is no longer detected
- Refrigeration detection system energizes blower if any R-454B refrigerant is detected to mitigate any concentrations of refrigerant from the unit and the system

CABINET

- 8** **Construction**
- Heavy-gauge steel panels
 - Full perimeter heavy-gauge galvanized steel base rail
 - Base rails have rigging holes
 - Three sides of the base rail have forklift slots
 - Raised edges around duct and power entry openings in the bottom of the unit for water protection

Airflow Choice

- Units are shipped in downflow (vertical) return air flow configuration

NOTE - Units can be field converted to horizontal air flow with optional Horizontal Return Air Panel Kit and Horizontal Roof Curb.

Power/Gas Entry

- Electrical and gas lines can be routed through the unit base or through horizontal access knock-outs

Exterior Panels

- Constructed of heavy-gauge, galvanized steel
- Textured pre-paint with polyurethane finish
- Cyclic salt fog and UV exposure up to 1,680 hours per ASTM D5894

Insulation

- Fully insulated with non-hygroscopic fiberglass insulation (conditioned areas)
- Unit base is fully insulated
- Base insulation serves as an air seal to the roof curb, eliminating the need to add a seal during installation

9 **Hinged Access Panels**

- Filter section
- Blower section
- Heating section
- Compressor/controls section
- Panel seals and quarter-turn latching handles provide a tight air and water seal

Required Selections

Airflow Configuration

- Specify downflow or horizontal

Options/Accessories

Factory Installed

Corrosion Protection

- Completely flexible immersed coating
- Electrodeposited dry film process (AST ElectroFin E-Coat)
- ASTM B117 / DIN 53167 Salt Spray - 15,000+ hours
- ASTM G85 Annex A3 SWAAT Modified Salt Spray - 3,000 hours
- VA Master Construction Specification Division 23 for High Humidity Installations
- CID AA-52474A (GSA)
- Indoor Corrosion Protection:
 - Coated coil
 - Coated reheat coil
 - Painted blower housing
 - Painted base
- Outdoor Corrosion Protection:
 - Coated coil
 - Painted outdoor base

FEATURES AND BENEFITS

CABINET (continued)

Options/Accessories

Factory or Field Installed

Combination Coil/Hail Guards

- Heavy gauge steel frame
- Painted to match cabinet
- Expanded metal mesh protects outdoor coil

Field Installed

Horizontal Return Air Panel Kit

- Required for horizontal applications with Horizontal Roof Curb
- Contains panel with return air opening for field replacement of existing unit panel and panel to cover bottom return air opening in unit
- See dimension drawings

BLOWER

A wide selection of supply air blower options are available to meet a variety of airflow requirements.

Motor

- Overload protected
- Ball bearings

NOTE - All blower motors 5 HP and above meet minimum energy efficiency standards in accordance with the Energy Independence and Security Act (EISA) of 2007

10 Supply Air Blower

- Forward curved blades
- Double inlet
- Blower wheel statically and dynamically balanced
- Ball bearings
- Adjustable pulley (allows speed change)
- Blower assembly slides out of unit for servicing
- Grease fittings furnished

Blower Proving Switch

- Monitors blower operation, shuts down unit if blower fails

Supply Static Pressure Transducer (VAV Models Only)

- Sends information to the Lennox® CORE unit controller to control VFD blower speed
- Shipped with the unit for remote field installation in the supply duct

Required Selections

Select VAV Variable Air Volume or MSAV® Multi-Stage Air Volume

- VAV Variable Air Volume, variable frequency drive (VFD) varies the air volume to maintain a constant duct static pressure
- MSAV models stage the amount of airflow according to compressor stages, heating demand, ventilation demand or smoke alarm
- Utilizes a Variable Frequency Drive (VFD) to stage the supply blower airflow
- VFD alters the frequency and voltage of the power supply to the blower to control blower speed
- The amount of airflow for each stage can be set according to a parameter in the Lennox® CORE Unit Controller
- Unit is shipped from the factory with preset airflow
- MSAV® Multi-Stage Air Volume can be ordered with or without an Electronic Bypass Control
- If equipped with the bypass control the MSAV® Multi-Stage Air Volume features manual (default) or automatic electronic bypass control of the VFD
- In case of a VFD malfunction, a VFD alarm is generated by the Lennox® CORE Unit controller
- VFD can be manually bypassed to continue unit operation at full blower speed or the unit controller can be set to automatically switch to full blower speed if a VFD alarm is generated
- VFD has an operational range of -40 to 125°F outdoor air ambient temperature
- Lower operating costs are obtained when the blower is operated on lower speeds

NOTE - Units equipped a Variable Frequency Drive (VFD) are designed to operate on balanced, three-phase power. Operating units on unbalanced three-phase power will reduce the reliability of all electrical components in the unit. Unbalanced power is a result of the power delivery system supplied by the local utility company. Factory-installed inverters are sized to drive blower motors with an equivalent current rating using balanced three-phase power. If unbalanced three-phase power is supplied, the installer must replace the existing factory-installed inverter with an inverter that has a higher current rating to allow for the imbalance. Refer to the installation instructions for additional information and replacement information.

Ordering Information

- Specify motor HP and drive kit number when base unit is ordered

Options/Accessories

Field Installed

Blower Belt Auto-Tensioner

- Provides proper tension to belt drive blower belt without the need for regular adjustments
- Maintains airflow and proper performance

FEATURES AND BENEFITS

ELECTRICAL

SmartWire™ System

- Keyed and color-coded wiring connectors prevent miswiring
- Wire coloring scheme is standardized across all models
- Each connection is intuitively labeled to make troubleshooting and servicing quick and easy

Electrical Plugs

- Positive connection electrical plugs connect common accessories or maintenance parts for easy removal or installation

Phase/Voltage Detection

- Monitors power supply to ensure correct phase at unit start-up
 - If phase is incorrect, the unit will not start and an alarm code reports to the unit controller
- Prevents unit start-up if the unit is the incorrect phase; unit start-ups in the wrong phase could lead to issues such as compressors functioning in reverse
- Monitors power supply voltage to ensure proper voltage
 - If voltage is not correct (over/under voltage conditions) the unit will not start and an alarm code reports to the unit controller

Required Selections

Voltage Choice

- Specify when ordering base unit

Options/Accessories

Factory Installed

Circuit Breakers

- HACR type
- For overload and short circuit protection
- Factory wired and mounted in the power entry panel
- Current sensitive and temperature activated
- Manual reset

Short-Circuit Current Rating (SCCR)

- Higher short circuit protection up to 100kA

NOTE - Disconnect Switch is furnished and factory installed with High SCCR option.

Factory or Field Installed

11 Disconnect Switch

- Accessible outside of unit
- Spring loaded weatherproof cover furnished

GFI Service Outlets (2)

- 115V ground fault circuit interrupter (GFCI) type options:
 - Factory installed, powered and wired
 - Factory installed, non-powered, field wired
 - Field installed, non-powered, field wired

Field Installed

GFI Weatherproof Cover

- Single-gang cover
- Heavy-duty UV-resistant polycarbonate case construction
- Hinged base cover with gasket

FEATURES AND BENEFITS

INDOOR AIR QUALITY

12 Air Filters

- Disposable 2 inch MERV 4 filters furnished as standard

Options/Accessories

Factory or Field Installed

Healthy Climate® High Efficiency Air Filters

- Disposable MERV 8 or MERV 13 (Minimum Efficiency Reporting Value based on ASHRAE 52.2) efficiency
- 2 inch pleated filters

Field Installed

Healthy Climate® High Efficiency MERV 16 Air Filters

- Disposable MERV 16 (Minimum Efficiency Reporting Value based on ASHRAE 52.2) efficiency
- 2 inch pleated filters

Healthy Climate® UVC Germicidal Light Kit

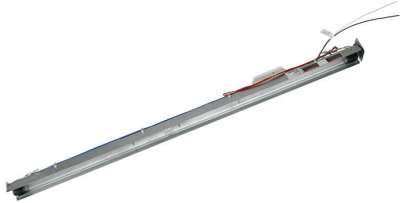

- Germicidal lamps emit ultra-violet (UV-C) energy, which has been proven to be effective in reducing microbes such as viruses, bacteria, yeasts, and molds
- UV-C energy greatly reduces the growth and proliferation of mold and other bioaerosols (bacteria and viruses) on illuminated surfaces (particularly coil and drain pan)
- Destroys the organism or controls its ability to reproduce
- Field installed in the blower/evaporator coil section
- Magnetic safety interlock terminates power when access panels are removed
- All necessary hardware for installation is included
- Lamps operate on 110/230V-1ph power supply

NOTE - Step-down transformer may be ordered separately for 460V and 575V units.

- Approved by ETL

Needlepoint Bipolar Ionization (NPBI) Kit

- NPBI technology integrates with system controls for effective air treatment
- Ionization has been shown to effectively reduce harmful pathogens, pollutants and odors
- Brush-type ionizer introduces a high concentration of both positive and negative ions into the airstream
- These bipolar ions are then dispersed into the occupied space through the duct system proactively reducing the airborne contaminants
- Ions travel within the building air stream and attach to particles, pathogens, and gas molecules, making them larger and easier to capture in the filtration system
- UL 2998 certified for zero ozone emission

Indoor Air Quality (CO₂) Sensors

- Monitors CO₂ levels
- Reports to the Lennox® CORE Control, which adjusts economizer dampers as needed

Replacement Filter Media Kit With Frame

- Replaces existing pleated filter media
- Includes washable metal mesh screen and metal frame with clip for holding replaceable non-pleated filter

CONTROL SYSTEM

LENNOX® CORE CONTROL SYSTEM

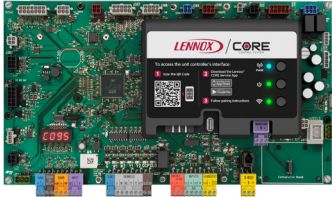

- 13 The Lennox® CORE Control System is designed to accelerate equipment install and service. Standard with all Enlight rooftop units, control system integrates key technologies that lower installation costs, drive system efficiency, and protect your investments.

The Lennox® CORE Unit Controller is a microprocessor-based controller that provides flexible control of all unit functions.

CORE Mobile Service App

- Guided Setup with progress indicators, detailed help, and exportable summaries to manage simple, trouble-free setup, reducing commissioning times
- Enhanced Test Functionality provides real-time sensor readings, trending, and reports that enable easy troubleshooting
- Ability to set and configure parameters of the CORE Control System to manage sequence of operation
- Economizer test function ensures economizer is operating correctly



Additional Features:

- Built-In 7-Segment Display shows Unit Status and active alarms for easy troubleshooting
- Buttons for test and clearing delays
- SmartWire™ System with keyed and removable screw terminals ensure correct field wiring
- Built-in BACnet MS/TP and IP allow open integration to building management systems.
- Two-port Ethernet Switch enables daisy chaining for BACnet IP and automatic firmware updates

NOTE - Unit Internet Connection required.

- Profile setup copies key settings between units with the same configuration to reduce setup time
- USB port allows a technician to download and transfer unit information to help verify service was performed
- USB software updates on the Lennox® CORE Unit Controller enhance functionality without the need to change components
- Unit Controller Software

Configurable Built-In Functions

- Discharge Air Cooling Control
- Up to three distinct Cooling Airflows in Thermostat Mode
- Programmable independent heating, ventilation and cooling blower speeds

- Discharge Air Heating Control
- Economizer Control Options (See Economizer / Exhaust Air / Outdoor Air sections)
- Exhaust Fan Control Modes for fresh air damper position
- Configurable Morning Warm-up
- Night Setback Mode
- Fresh Air Tempering for Improved Ventilation
- Demand Control Ventilation
- Low Ambient Controls for operation down to 0°F
- Humiditrol® Operation
- Enhanced Dehumidification (Latent Demand Control without hot has reheat)

Component Protection / Unit Safeguards:

- Compressor Time-Off Delay
- Adjustable Blower On/Off Delay
- Return Air Temperature Limit Control
- Safety Switch Input allows Controller to respond to a external safety switch trip
- Service Relay Output
- Thermostat Bounce Delay
- Smoke Alarm Mode has four choices (unit off, positive pressure, negative pressure, purge)
- "Strike Three" Protection
- Gas Valve Time Delay Between First and Second Stage
- Minimum Compressor Run Time

Control Methods / Interfaces:

- DDC and 24V Thermostat
- BACnet MS/TP and IP
- LONTalk (Factory and Field Option)
- Lennox S-BUS
- Zone Temperature Sensor Input
- Dehumidistat and Humidity Sensor Inputs
- Indoor Air Quality Inputs (2)
- Built-in Control Parameter Defaults
- Permanent Diagnostic Code Storage
- Field Adjustable Control Parameters (Over 200 settings)
- Multiple Configurable Digital Inputs
- LED Indicators
- PC Interface connects the Lennox® CORE Unit Controller to a PC with the Lennox Unit Controller Software

NOTE - Lennox® CORE Control System features vary with the type of rooftop unit in which the control is installed.

CONTROL SYSTEM

LENNOX® CORE CONTROL SYSTEM (continued)

Controls Options

Factory or Field Installed

Dirty Filter Switch

- Senses static pressure increase and issues alarm if necessary

Fresh Air Tempering

- Used in applications with high outside air requirements
- Controller energizes the first stage heat as needed to maintain a minimum supply air temperature for comfort, regardless of the thermostat demand
- When ordered as a factory option, sensor ships with the unit for field installation

Smoke Detector

- Photoelectric type
- Installed in supply air section, return air section or both sections
- Available with power board and single sensor (supply or return) or power board and two sensors (supply and return)
- Power board located in unit control compartment

Commercial Control Systems

Interoperability via BACnet® or LonTalk® Protocols

- Communication compatible with third-party automation systems that support the BACnet Application Specific Controller device profile, LonMark® Space Comfort Controller functional profile, or LonMark Discharge Air Controller functional profile

Field Installed

Thermostats and Room Sensors

- Control system and thermostat options, see page 16

OPTIONS / ACCESSORIES

ECONOMIZER

- Economizer operation is set and controlled by the Lennox® CORE Unit Controller
- Simple plug-in connections from Economizer to unit controller for easy installation
- All Enlight rooftop units are equipped with factory installed CEC Title 24 approved sensors for outside, return and discharge air temperature monitoring

NOTE - Optional sensors may be used instead of unit sensors to determine whether outdoor air is suitable for free cooling. See Options/Accessories table.

Factory or Field Installed

14 High Performance Economizer

- Approved for California Title 24 building standards
- Low leakage dampers are Air Movement and Control Association International (AMCA) Class 1A Certified - Maximum 3 CFM per sq. ft. leakage at 1 in. w.g.
- ASHRAE 90.1 and IECC compliant
- Downflow or Horizontal with Outdoor Air Hood
- Outdoor Air Hood with mist elimination is included when Economizer is factory installed and is furnished with Economizer when ordered for field installation

NOTE - Downflow or horizontal economizer applications require optional Downflow or Horizontal Barometric Relief Dampers with Exhaust Hood.

- Linked damper action
- High torque 24-volt fully-modulating spring return damper motor
- Return air and outdoor air dampers
- Plug-in connections to unit

NOTE - High Performance Economizers are not approved for use with enthalpy controls in Title 24 applications.

NOTE - The Free Cooling setpoint for Title 24 applications must be set based on the Climate Zone where the system is installed. See Section 140.4 "Prescriptive Requirements for Space Conditioning Systems" of the California Energy Commission's 2022 Building Energy Efficiency Standards.

NOTE - Refer to Installation Instructions for complete setup information.

Differential Sensible Control

- Factory setting
- Uses outdoor air and return air sensors that are furnished with the unit
- The Lennox® CORE Unit Controller compares outdoor air temperature with return air
- When the outdoor air is below the configured setpoint and cooler than return air, the controller activates the Economizer

OPTIONS / ACCESSORIES

ECONOMIZER (continued)

Factory or Field Installed

NOTE - Differential Sensible Control can be configured in the field to provide Offset Differential Sensible Control or Single Sensible Control.

NOTE - In Offset Differential Sensible Control mode, the Economizer is enabled if the temperature differential (offset) between outdoor air and return air reaches the configured setpoint. In Single Sensible Control mode, the Economizer is enabled when outdoor air temperature falls below the configured setpoint.

Global Control

- Unit controller communicates with a DDC system with one global sensor (enthalpy or sensible)
- Determines whether outside air is suitable for free cooling on all units connected to the control system
- Sensor must be field provided

Single Enthalpy Control (Not for Title 24)

- Outdoor air enthalpy sensor enables Economizer if the outdoor enthalpy is less than the setpoint of the control

Differential Enthalpy Control (Not for Title 24)

- Order two Single Enthalpy Controls
- One is field installed in the return air section
- One is installed in the outdoor air section
- Allows the Economizer control to select between outdoor air or return air, whichever has lower enthalpy

Field Installed

Outdoor Air CFM Control

- Maintains constant outdoor air volume levels on the supply air fan and varying unit airflows
- Velocity sensor located in the rooftop unit outdoor air section, the Lennox® CORE Unit Controller changes the Economizer position to help minimize the effect of supply fan speed changes on outdoor air volume levels
- Setpoint for outdoor air volume is established by field testing

NOTE - Not available with Demand Control Ventilation (CO₂ Sensor) or Building Pressure Control.

Building Pressure Control

- Maintains constant building pressure level
- Includes a static pressure transducer and outdoor static pressure assembly
- Using differential pressure information between the outdoor air and the building air, the Lennox® CORE Unit Controller changes the Economizer position to help maintain a constant building pressure

NOTE - Not available with Demand Control Ventilation (CO₂ Sensor) or Outdoor Air CFM Control.

EXHAUST

Factory or Field Installed

15 Downflow Barometric Relief Dampers

- Allow relief of excess air
- Aluminum blade dampers prevent blow back and outdoor air infiltration during off cycle
- Exhaust hood is factory installed when dampers are factory installed with Economizer
- Exhaust hood is furnished with dampers when ordered for field installation
- Bird screen furnished

16 Power Exhaust Fans

- Install internal to unit for downflow applications only with Economizer option
- Provides exhaust air pressure relief
- Interlocked to run when supply air blower is operating
- Fans run when outdoor air dampers are 50% open (adjustable)
- Motor is overload protected
- Dual propeller type fans are 20 in. diameter
- Five blades
- Two 1/3 HP motors
- SCCR rated

NOTE - Requires Economizer with furnished Outdoor Air Hood and Downflow Barometric Relief Dampers.

NOTE - All models are equipped with 2-stage power exhaust fans. Power exhaust operates in 1st stage (one fan) up to 70% of supply air blower speed. Both exhaust fans operate in 2nd stage when supply air blower speed is above 70% (adjustable) of full speed.

Field Installed

Horizontal Barometric Relief Dampers

- For use when unit is configured for horizontal applications requiring an Economizer
- Allows relief of excess air
- Aluminum blade dampers prevent blow back and outdoor air infiltration during off cycle
- Field installed in return air duct
- Bird screen and hood furnished

OPTIONS / ACCESSORIES

OUTDOOR AIR

Factory or Field Installed

Motorized Outdoor Air Dampers

- Linked mechanical dampers
- Fully modulating spring return damper motor with plug-in connection
- 0 to 25% (fixed) outdoor air adjustable
- Installs in unit
- Outdoor air hood with bird screen included

NOTE - Outdoor Air Hood is shipped separately in the unit with factory installed dampers for field installation.

Field Installed

Manual Outdoor Air Damper

- Adjustable slide damper
- Installed in unit
- Outdoor air hood with bird screen included

ROOF CURBS

Field Installed

- Nailer strip furnished (downflow only)
- Mates to unit
- US National Roofing Contractors Approved
- Shipped knocked down

Downflow

Hybrid Roof Curbs

- Interlocking tabs fasten corners together
- No tools required for assembly
- Can also be fastened together with furnished hardware
- Available in 8, 14, 18, and 24 inch heights

Adjustable Pitch Curb

- Fully adjustable pitch curbs (3/4 in. per foot in any direction) provide a level platform for rooftop units allowing flexible installations on roofs with uneven or sloped angles
- Interlocking tabs fasten corners together
- No tools required for assembly
- Hardware is furnished to connect upper curb with lower curb
- Available in 14 inch height

Horizontal

- Meet National Roofing Code requirements
- Converts unit from downflow to horizontal (side) air flow
- Return air is on unit
- Supply air is on curb
- See dimension drawings
- Available in 26, 30, 37, and 41 inch heights

NOTE - Requires Horizontal Return Air Panel Kit.

NOTE - Optional Insulation Kit is available to help prevent sweating.

Adaptor Curbs (not shown)

- Curbs are regionally sourced
- Dimensions vary based upon the source

NOTE - Contact your local sales representative for a detailed cut sheet with applicable dimensions.

CEILING DIFFUSERS

Field Installed

Ceiling Diffusers (Flush or Step-Down)

- White powder coat finish on diffuser face and grilles
- Insulated UL listed duct liner
- Diffuser box has collars for duct connection
- Step-down diffusers have double deflection blades
- Flush diffusers have fixed blades
- Provisions for suspending
- Internally sealed to prevent recirculation
- Removable return air grille
- Adapts to T-bar ceiling grids or plaster ceilings

Transitions (Supply and Return)

- Used with diffusers
- Installs in roof curb
- Galvanized steel construction
- Flanges furnished for duct connection to diffusers
- Fully insulated

HUMIDITROL® DEHUMIDIFICATION SYSTEM OPTION

OVERVIEW

NOTE - Humiditrol® Dehumidification System Only
Available for MSAV® Multi-Stage Air Volume
Models

- Factory installed option designed to control humidity
- Provides dehumidification on demand using ASHRAE 90.1 recommended method for comfort conditioning humidity control
- Unit comes equipped with one row reheat coil, solenoid valve

NOTE - A dehumidification demand from a relative humidity sensor, dehumidistat, a DDC controller or building automation system is required to control humidity.

Controls are not furnished and must be ordered extra.

BENEFITS

- Improves indoor air quality
- Helps prevent damage due to high humidity levels
- Improves comfort levels by reducing space humidity levels

OPERATION

No Dehumidification Demand

- The unit will operate conventionally whenever there is a demand for cooling or heating and no dehumidification demand
- Free cooling is only permitted when there is no demand for dehumidification

Dehumidification Demand Only

- Reheat operation will initiate on a dehumidification demand and does not require a cooling demand
- Unit will operate in the dehumidification mode until the relative humidity of the conditioned space is below the setpoint
- Reheat coil is sized to provide 68°F to 75°F supply air during reheat operation
- This reduces sensible cooling capacity and extends compressor run time to control humidity when the cooling load is low
- A solenoid valve diverts hot gas from the compressor to the reheat coil
- Cooled and dehumidified air from the evaporator is reheated as it passes through the reheat coil
- De-superheated and partially condensed refrigerant continues to the outdoor condenser coil where condensing is completed
- Unit will continue to operate in this mode until the dehumidification demand is satisfied

Dehumidification and Cooling Demand (Thermostat/ Room Sensor Application)

- If both a dehumidification and a full cooling load demand occur, the system will operate in cooling until the cooling demand is satisfied
- Then the system will energize the dehumidification mode

HUMIDITROL® DEHUMIDIFICATION SYSTEM OPTION

REFRIGERANT SCHEMATIC (156 MODEL ONLY)

NOTE - Two refrigerant circuits operate during reheat.

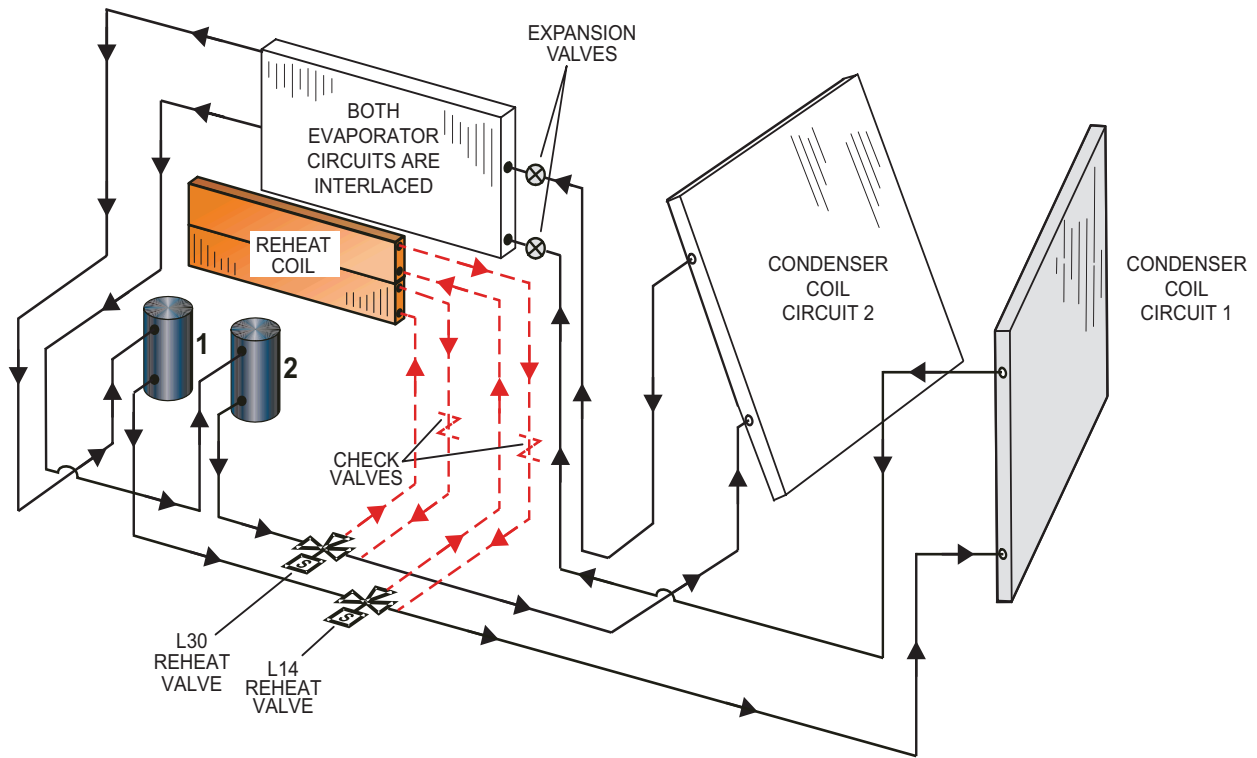

REFRIGERANT SCHEMATIC (180 MODEL ONLY)

NOTE - Two refrigerant circuits operate during reheat.

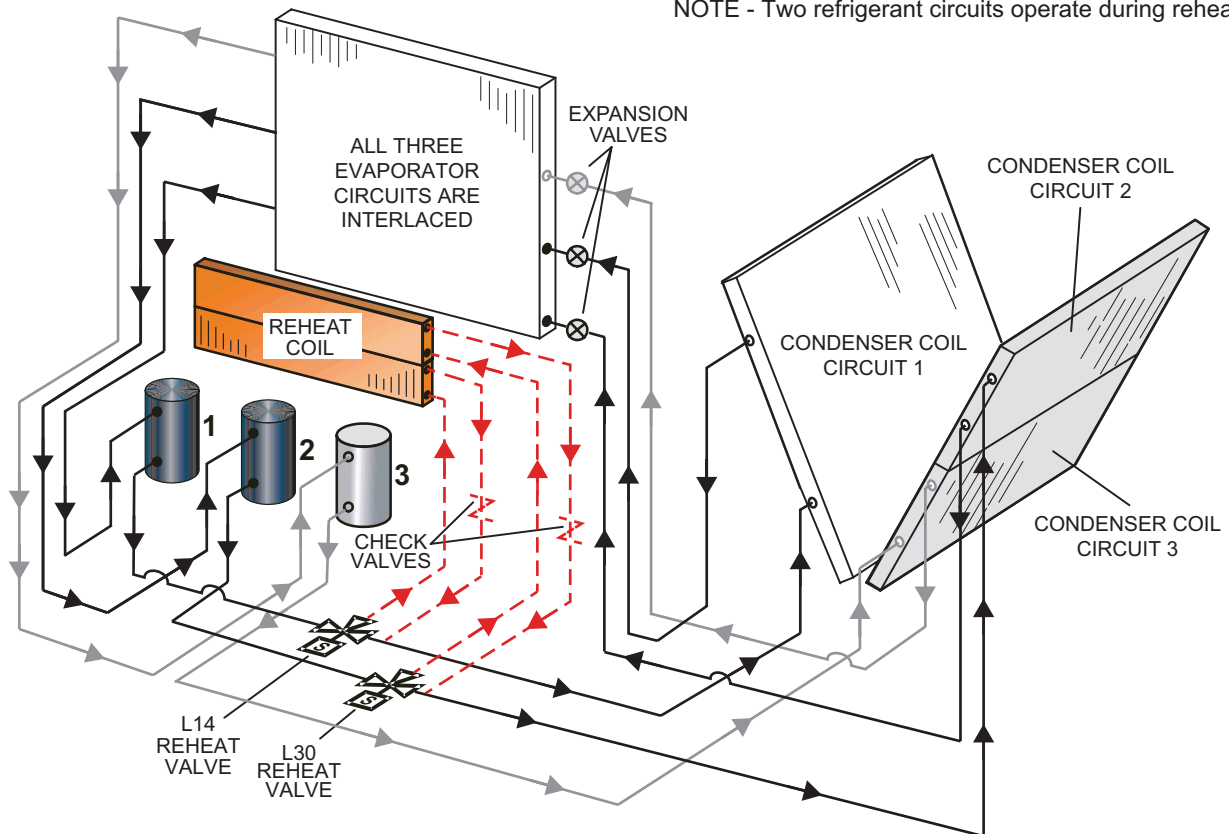

HUMIDITROL® DEHUMIDIFICATION SYSTEM OPTION

REFRIGERANT SCHEMATIC (210, 240 and 300 MODELS ONLY)

NOTE - Two refrigerant circuits operate during reheat.

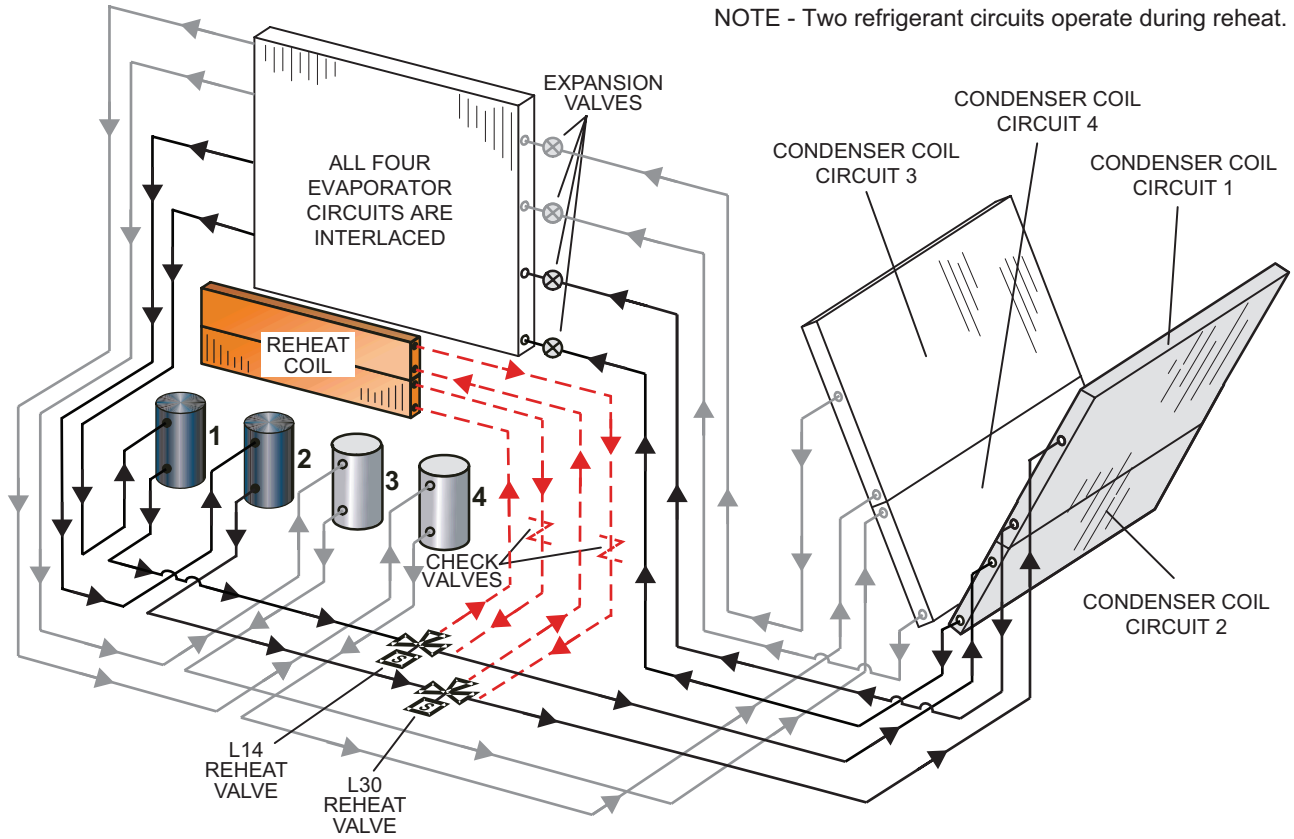

OPTIONAL CONVENTIONAL TEMPERATURE CONTROL SYSTEMS

CS8500 Commercial 7-Day Programmable Thermostat

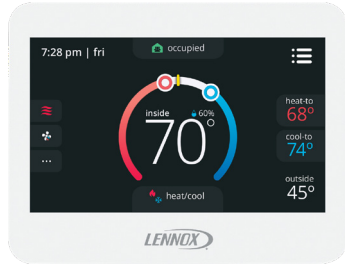

- Fully Communicating Sensor
- Full Color Touchscreen Interface
- Variable Speed System Control (On Compatible Units)
- Up To 4 Heat / 4 Cool
- Built-In Sensors For Temperature, Humidity And Optional CO₂
- Remote Sensor Options For Occupancy, Temperature
- BACnet Capable Options
- 5-2 or 7-Day Scheduling
- Smooth Setback Recovery
- Heat/Cool Auto-Changeover
- Four-Wire Installation
- FDD, ASHRAE, IECC Compliant

CS7500 Commercial 7-Day Programmable Thermostat



- Premium Universal Thermostat
- Full Color Touchscreen Interface
- Up To 4 Heat / 3 Cool
- Built-In Sensors For Temperature and Humidity
- Remote Sensors Options For Temperature, Discharge Air, Outdoor Air
- 5-2 or 7-Day Scheduling
- Smooth Setback Recovery
- Heat/Cool Auto-Changeover
- FDD, ASHRAE, IECC Compliant

CS3000 Commercial 5-2 Day Programmable Thermostat

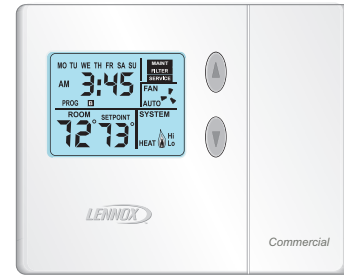

- Conventional Multi-Stage Thermostat
- Intuitive Display
- Push-Button Operation
- Up To 2 Heat / 2 Cool
- Built-In Temperature Sensor
- Remote Temperature Sensing
- Up to 5-2 Day Scheduling
- Smooth Setback Recovery
- Heat/Cool Auto-changeover

Wired Temperature/Humidity Room Sensor (Non-Communicating)



- Terminal blocks for wiring connections
- Five-wire sensor connection
- Off-white plastic enclosure
- Non-adjustable
- Relative humidity range: 0 -100%
- +/- 3% Accuracy

OPTIONAL CONVENTIONAL TEMPERATURE CONTROL SYSTEMS

Description	Order Number
CS8500 Commercial 7 Day Programmable Thermostat	
CS8500 7-Day Thermostat	No CO ₂ Sensing 24K55
	With CO ₂ Sensing 24K53
Sensors/Accessories	¹ Remote non-adjustable wall-mount 10k 47W37
	¹ Remote non-adjustable wall-mount 11k 94L61
Sysbus Network Cable (Yellow) for CS8500 and LCS-5030 Wired Room Sensor	
Twisted pair 100% shielded communication cable, Red and Black	500 ft. box 27M19
22 AWG, yellow jacket, rated at 75°C, 300V, Plenum rated	1000 ft. box 94L63
Insulation - Low smoke PVC, NEC, CMP	2500 ft. roll 68M25
CS7500 Commercial 7-Day Programmable Thermostat	
CS7500 7-Day Thermostat	24K41
Sensors/Accessories	² Remote non-adjustable wall-mount 20k 47W36
	² Remote non-adjustable wall-mount 10k 47W37
	Remote non-adjustable discharge air (duct mount) 19L22
	Outdoor temperature sensor X2658
CS3000 Commercial 5-2 Day Programmable Thermostat	
CS3000 5-2 Day Thermostat	11Y05
Sensors/Accessories	Remote non-adjustable wall mount 10k averaging 47W37
	Thermostat wall mounting plate X2659
Universal Thermostat Guard with Lock (clear)	
	Inside Dimensions (H x W x D) 5-7/8 x 8-3/8 x 3 in. 39P21
Temperature/Humidity Room Sensor	
A335MT13AE1 Wired Temperature/Humidity Room Sensor (Non-Communicating)	21W06

¹ Up to nine of the same type remote temperature sensors can be connected in parallel.

² Remote wall-mount sensors can be applied in any of the following combinations:
 One Sensor - (1) 47W36, Two Sensors - (2) 47W37, Three Sensors - (2) 47W36 and (1) 47W37
 Four Sensors - (4) 47W36, Five Sensors - (3) 47W36 and (2) 47W37

Objective: Outline the unit functions as a result of room thermostat or zone sensor demands.

Given: When economizer is present, it will function as an integral part of the unit cooling system. When not present, unit will function as if economizer is present but outdoor ambient is high and sensed as not suitable.

156 MODELS (2 COMPRESSORS)

UNIT OPERATION WITH 2-STAGE THERMOSTAT (2 COOL AND 2 HEAT STAGES, Y1, Y2, W1, W2)

SUPPLY AIR BLOWER SPEED

Unit has following supply air blower speed setting:

- Ventilation speed
- Cooling Speed – Low
- Cooling Speed – High
- Heating speed
- Smoke speed (Used only in smoke removal option - not discussed)

¹ Unit Features An Economizer And Outdoor Air Is Suitable

Y1 Demand:

All compressors are off, supply air blower is on low cooling speed to minimize blower power consumption, economizer modulates (minimum to maximum open position) to maintain 55°F supply air temperature (default unit controller setting).

Y2 Demand:

All compressors are off, supply air blower is on high cooling speed providing higher cooling capacity, and economizer modulates to maintain 55°F supply air temperature. If economizer stays at maximum open for 3 minutes, compressor 1 is energized at full cooling capacity while supply air blower stays on high cooling speed providing maximum cooling capacity.

¹ Outdoor air suitability is determined by the energy state of outdoor ambient (enthalpy or sensible) and its ability to achieve the desired free cooling effects. Outdoor air suitability can also be determined by a third party controller and provided to the rooftop unit via a network connection.

Unit Does Not Feature An Economizer Or Outdoor Air Is Not Suitable

Y1 Demand:

Compressor 1 operates at full cooling capacity and supply air blower operates at low cooling speed.

Y2 Demand:

All compressors operate at max cooling capacity and supply air blower operates at high cooling speed.

Dehumidification Mode

If a unit with Humiditrol® Dehumidification Option receives a call for dehumidification, economizer free cooling is locked out.

Call For Dehumidification, No Y1, Y2 demand:

1st and 2nd stage compressor operate at max cooling capacity, supply air blower operates at low cooling speed, and the reheat valves 1,2 are energized.

Y1 Demand With A Call For Dehumidification:

All compressors operate at max cooling capacity, supply air blower operates at high cooling speed, reheat valve 1 is energized, reheat valve 2 is de-energized.

Y2 Demand With A Call For Dehumidification:

All compressors operate at max cooling capacity, supply air blower operates at high cooling speed, and the reheat valves 1,2 are de-energized.

156 MODELS (2 COMPRESSORS)**UNIT OPERATION WITH 3-STAGE THERMOSTAT OR ZONE SENSOR (3 COOL AND 2 HEAT STAGES, Y1, Y2, Y3 AND W1, W2)**

Unit has following supply air blower speed setting:

- Ventilation speed
- Cooling Speed – Low
- Cooling Speed – Medium
- Cooling Speed – High
- Heating speed
- Smoke speed (Used only in smoke removal option - not discussed)

¹ Unit Features An Economizer And Outdoor Air Is Suitable

Cooling - Thermostat or Zone Sensor Mode (Y1, Y2, Y3)

Y1 Demand:

All compressors are off, supply air blower is on medium cooling speed to minimize blower power consumption, economizer modulates (minimum to maximum open position) to maintain 55°F supply air temperature (default unit controller setting).

Y2 Demand:

All compressors are off, supply air blower is on high cooling speed providing higher cooling capacity, and economizer modulates to maintain 55°F supply air temperature. If economizer stays at maximum open for 3 minutes, compressor 1 is energized at part load capacity while supply air blower stays on high cooling speed providing maximum cooling capacity. After compressors are energized the economizer stays at maximum open.

Y3 Demand:

Compressors 1 is energized at full capacity while supply air blower stays on high cooling speed, economizer stays at maximum open.

¹ Outdoor air suitability is determined by the energy state of outdoor ambient (enthalpy or sensible) and its ability to achieve the desired free cooling effects. Outdoor air suitability can also be determined by a third party controller and provided to the rooftop unit via a network connection.

Unit Does Not Feature An Economizer or Outdoor Air Is Not Suitable**Y1 Demand:**

Compressor 1 operates at part load and supply air blower operates at low cooling speed.

Y2 Demand:

Compressor 1 operates at part load with compressor 2 ON, and supply air blower operates at medium cooling speed.

Y3 Demand:

All compressors operate at full capacity and supply air blower operates at high cooling speed.

Dehumidification Mode

If a unit with Humiditrol® Dehumidification Option receives a call for dehumidification, economizer free cooling is locked out.

Call For Dehumidification, No Y1, Y2 Demand:

Compressor 1,2 operates at full cooling capacity, supply air blower operates at low cooling speed, and the reheat valves 1,2 are energized.

Y1 Demand With A Call For Dehumidification:

Compressor 1,2 operates at full cooling capacity, supply air blower operates at low cooling speed and the reheat valve 1 is energized, reheat valve 2 is de-energized.

Y2 Demand With A Call For Dehumidification:

Compressor 1,2 operates at full cooling capacity, supply air blower operates at high cooling speed and the reheat valve 1 is energized, reheat valve 2 is de-energized.

Y3 Demand With A Call For Dehumidification:

Compressor 1,2 operates at full cooling capacity, supply air blower operates at high cooling speed, and the reheat valves 1,2 are de-energized.

180/210/240/300 MODELS (3 AND 4 COMPRESSORS)**UNIT OPERATION WITH 2-STAGE THERMOSTAT (2 COOLING STAGES, Y1, Y2)****SUPPLY AIR BLOWER SPEED**

Unit has the following supply air blower speed settings:

- Ventilation speed
- Cooling speed - Low
- Cooling speed - High
- Heating speed
- Smoke speed (Used only in smoke removal option - not discussed)

¹ Unit Features An Economizer And Outdoor Air Is Suitable**Y1 Demand:**

All compressors are off, supply air blower is on low cooling speed to minimize blower power consumption, economizer modulates (minimum to maximum open position) to maintain 55°F supply air temperature (default unit controller setting).

Y2 Demand:

All compressors are off, supply air blower is on high cooling speed providing higher cooling capacity, and economizer modulates to maintain 55°F supply air temperature.

If economizer stays at maximum open for 3 minutes, 1st stage compressors (compressor 1 and 2) are energized while supply air blower stays on high cooling speed providing maximum cooling capacity.

¹ Outdoor air suitability is determined by the energy state of outdoor ambient (enthalpy or sensible) and its ability to achieve the desired free cooling effects. Outdoor air suitability can also be determined by a third party controller and provided to the RTU via a network connection.

Unit Does Not Feature An Economizer Or Outdoor Air Is Not Suitable**Y1 Demand:**

1st stage compressors operate and supply air blower operates at low cooling speed.

Y2 Demand:

All compressors operate and supply air blower operates at high cooling speed.

Dehumidification Mode

If a unit with Humiditrol® Dehumidification Option receives a call for dehumidification, economizer free cooling is locked out.

Call For Dehumidification, No Y1, Y2 Demand:

1st stage compressors (1 & 2) operate, supply air blower operates at low cooling speed, and the reheat valves are energized.

Y1 Demand With A Call For Dehumidification:

All compressors operate, supply air blower operates at high cooling speed and the reheat valves are energized.

Y2 Demand With A Call For Dehumidification:

All compressors operate, supply air blower operates at high cooling speed, and the reheat valves are de-energized.

180/210/240/300 MODELS (3 AND 4 COMPRESSORS)**UNIT WITH 3-STAGE THERMOSTAT (3 COOLING STAGES, Y1, Y2, Y3) OR 3 COMPRESSORS MODELS - ZONE SENSOR (4 COOLING STAGES, Y1, Y2, Y3, Y4)****SUPPLY AIR BLOWER SPEED**

Unit has following supply air blower speed setting:

- Ventilation speed
- Cooling speed - Low
- Cooling speed - Medium
- Cooling speed - High
- Heating speed
- Smoke speed (Used only in smoke removal option - not discussed)

¹ Unit Features An Economizer And Outdoor Air Is Suitable**3 Compressor Units****Y1 Demand:**

All compressors are off, supply air blower is on low cooling speed to minimize blower power consumption, economizer modulates (minimum to maximum open position) to maintain 55°F supply air temperature (default unit controller setting).

Y2 Demand:

All compressors are off, supply air blower is on high cooling speed providing higher cooling capacity, economizer modulates (minimum to maximum open position) to maintain 55°F supply air temperature (default unit controller setting).

If economizer stays at maximum open for 3 minutes then compressor 1 is energized while supply air blower stays on high cooling speed. After compressor is energized the economizer stays at maximum open.

Y3 Demand:

Compressors 1 and 2 are energized while supply air blower stays on high cooling speed. After compressors are energized the economizer stays at maximum.

Y4 (Zone Sensor Only) Demand:

All compressors are energized and supply air blower stays on high cooling speed.

4 Compressor Units**Y1 Demand:**

All compressors are off, supply air blower is on low cooling speed to minimize blower power consumption, economizer modulates (minimum to maximum open position) to maintain 55°F supply air temperature (default unit controller setting).

Y2 Demand:

All compressors are off, supply air blower is on high cooling speed providing higher cooling capacity, economizer modulates (minimum to maximum open position) to maintain 55°F supply air temperature (default unit controller setting).

If economizer stays at maximum open for 3 minutes then compressors 1 and 2 are energized while supply air blower stays on high cooling speed. After compressors are energized the economizer stays at maximum open.

Y3 Demand:

Compressors 1, 2 and 3 are energized and supply air blower stays on high cooling speed.

¹ Outdoor air suitability is determined by the energy state of outdoor ambient (enthalpy or sensible) and its ability to achieve the desired free cooling effects. Outdoor air suitability can also be determined by a third party controller and provided to the RTU via a network connection.

180/210/240/300 MODELS (3 AND 4 COMPRESSORS) (CONTINUED)
UNIT WITH 3-STAGE THERMOSTAT (3 COOLING STAGES, Y1, Y2, Y3) OR 3 COMPRESSORS MODELS - ZONE SENSOR (4 COOLING STAGES, Y1, Y2, Y3, Y4)

Unit Does Not Feature An Economizer Or Outdoor Air Is Not Suitable

3 Compressor Units

Y1 Demand:

Compressor 1 operates and supply air blower operates at low cooling speed.

Y2 Demand:

Compressors 1 and 2 operate and supply air blower operates at medium cooling speed.

Y3 or Y4 (Zone Sensor Only) Demand:

All compressors operate and supply air blower operates at high cooling speed .

4 Compressor Units

Y1 Demand:

Compressors 1 and 2 operate and supply air blower operates at low cooling speed.

Y2 Demand:

Compressors 1, 2, and 3 operate and supply air blower operates at medium cooling speed.

Y3 Demand:

All compressors operate and supply air blower operates at high cooling speed.

Dehumidification Mode

If a unit with Humiditrol® Dehumidification Option receives a call for dehumidification, economizer free cooling is locked out.

Call For Dehumidification, No Y1, Y2, Y3 Demand:

Compressor 1 and 2 operate, supply air blower operates at high cooling speed, and both reheat valves are energized.

Y1 Demand With A Call For Dehumidification:

All compressors operate, supply air blower operates at high cooling speed and both reheat valves are energized.

Y2 Demand With A Call For Dehumidification:

All compressors operate, supply air blower operates at high cooling speed, and the reheat valve of refrigeration circuit 1 is energized while the reheat valve of refrigeration circuit 2 is de-energized.

Y3 or Y4 (Zone Sensor Only) Demand:

All compressors operate, supply air blower operates at high cooling speed, and both reheat valves are de-energized.

Heating Mode

NOTE – HEATING MODE CAN BE SET TO TWO-STAGE IN THERMOSTAT MODE OR AT FOUR-STAGE IN ROOM SENSOR MODE CONTROL OPTIONS.

Two-Stage Operation (Thermostat Mode)**W1 Demand:**

Both gas valves are open on Low Fire (stage 1 on units with 2-stage gas valves) and supply air blower operates at heating speed

W2 Demand:

Both gas valves are open on High Fire (stage 2 on units with 2-stage gas valves) and supply air blower operates at heating speed

Four-Stage Operation (Room Sensor Mode)**W1 Demand:**

Left heat exchanger gas valve is open on Low Fire (stage 1 on units with 4-stage gas valves) and supply air blower operates at heating speed.

W2 Demand:

Both gas valves are open on Low Fire (stage 2 on units with 4-stage gas valves) and supply air blower operates at heating speed.

W3 Demand:

Left heat exchanger gas valve will open on High Fire and the right heat exchanger will remain open on Low Fire (stage 3 on units with 4-stage gas valves) and supply air blower operates at heating speed.

W4 Demand:

Both gas valves are open on High Fire (stage 4 on units with 4-stage gas valves) and supply air blower operates at heating speed.

Modulating Outdoor Air Damper

The minimum damper position for “occupied low blower” and “occupied high blower” is adjusted during unit setup to provide minimum fresh air requirements per ASHRAE 62.1 at the corresponding supply air blower speeds.

- When supply air blower is off or the unit is in unoccupied mode, the outdoor air damper is closed.
- When unit is in occupied mode and supply air blower is operating at a speed below the “midpoint” blower speed, the outdoor air damper is at minimum “low blower” position.
- When unit is in occupied mode and supply air blower is operating at a speed equal to or above the “midpoint” blower speed, the outdoor air damper is at minimum “high blower” position.

NOTE - The “midpoint” blower speed is an average of the minimum and maximum blower speed (minimum speed + maximum speed divided by 2).

Power Exhaust Operation

NOTE - POWER EXHAUST OPERATION IS THE SAME FOR ALL CONTROL OPTIONS

MSAV® models are equipped with 2-stage power exhaust fans. Power exhaust fans operate when economizer outdoor air dampers are 50% open (adjustable). Power exhaust operates in 1st stage (one fan) up to 70% of supply air blower speed. 2nd stage power exhaust fans (both fans) operate when supply air blower speed is above 70% (adjustable) of full speed.

210/240/300 MODELS (4 COMPRESSORS)**VAV UNITS WITH ZONE SENSOR (4 COOLING STAGES, Y1, Y2, Y3, Y4)****SUPPLY AIR BLOWER SPEED**

Unit has following supply air blower speed setting:

- Ventilation speed
- Cooling speed - Low
- Cooling speed - Medium-Low
- Cooling speed - Medium-High
- Cooling speed - High
- Heating speed
- Smoke speed (Used only in smoke removal option - not discussed)

¹ Unit Features An Economizer And Outdoor Air Is Suitable**Y1 Demand:**

All compressors are off, supply air blower is on low cooling speed to minimize blower power consumption, economizer modulates (minimum to maximum open position) to maintain 55°F supply air temperature (default unit controller setting).

Y2 Demand:

All compressors are off, supply air blower is on high cooling speed providing higher cooling capacity, and economizer modulates to maintain 55°F supply air temperature.

If economizer stays at maximum open for 3 minutes, compressor 1 is energized while supply air blower stays on high cooling speed. After compressor 1 is energized the economizer stays at maximum open.

Y3 Demand:

Compressor 1 and 2 are energized while supply air blower is on high cooling speed providing even higher cooling capacity.

Y4 Demand:

All compressors are energized while supply air blower is on high cooling speed providing maximum cooling capacity.

¹ Outdoor air suitability is determined by the energy state of outdoor ambient (enthalpy or sensible) and its ability to achieve the desired free cooling effects. Outdoor air suitability can also be determined by a third party controller and provided to the RTU via a network connection.

Unit Does Not Feature An Economizer Or Outdoor Air Is Not Suitable**Y1 Demand:**

Compressor 1 operates and supply air blower operates at low cooling speed.

Y2 Demand:

Compressors 1 and 2 operate and supply air blower operates at medium-low cooling speed.

Y3 Demand:

Compressors 1, 2, and 3 operate and supply air blower operates at medium-high cooling speed.

Y4 Demand:

All compressors operate and supply air blower operates at high cooling speed.

210/240/300 MODELS (4 COMPRESSORS) (CONTINUED)
VAV UNITS WITH ZONE SENSOR (4 COOLING STAGES, Y1, Y2, Y3, Y4)

Dehumidification Mode

If a unit with Humiditrol® Dehumidification Option receives a call for dehumidification, economizer free cooling is locked out.

Call For Dehumidification, No Y1, Y2, Y3, Y4 Demand:

Compressors 1 and 2 operate, supply air blower operates at low cooling speed, and both reheat valves are energized.

Y1 Demand With A Call For Dehumidification:

Compressors 1, 2, and 3 operate, supply air blower operates at high cooling speed and both reheat valves are energized.

Y2 Demand With A Call For Dehumidification:

All compressors operate, supply air blower operates at high cooling speed, and both reheat valves are energized.

Y3 Demand With A Call For Dehumidification:

All compressors operate, supply air blower operates at high cooling speed, and the reheat valve of compressor 1 is energized while the reheat valve of compressor 2 is de-energized.

Y4 Demand With A Call For Dehumidification:

All compressors operate, supply air blower operates at high cooling speed, and the reheat valves are de-energized.

156 MODELS (2 COMPRESSORS)**VAV UNITS IN ZONING APPLICATIONS OPERATING WITH DISCHARGE AIR CONTROL (2 HEAT / 3 COOL)****SUPPLY AIR BLOWER SPEED**

Unit has the following supply air blower speed settings:

- Ventilation Speed
- Cooling Speed - Fully modular based on supply duct static pressure
- Heating Speed
- Smoke Speed (Used only in smoke removal option - not discussed)

Cooling Mode (3 Cool)

- Discharge air temperature (DAT) can be used to control unit staging.
- DAT default setpoint = 55°F. Unit will stage compressors as required to maintain the setpoint when provided with Y1 thermostat demand.
- Increasing compressor stages provides more cooling capacity while decreasing compressor stages provides less cooling capacity.

¹ Unit Features An Economizer And Outdoor Air Is Suitable**Y1 Demand:**

All compressors are off, supply air blower operates to maintain duct static pressure, economizer modulates (minimum to maximum open position) to maintain 55°F supply air temperature (default unit controller setting).

Y2 Demand:

All compressors are off, supply air blower operates to maintain duct static pressure, and economizer modulates to maintain 55°F supply air temperature. If economizer stays at maximum open for 3 minutes, compressor 1 is energized at part load capacity supply air blower operates to maintain duct static pressure. Economizer modulates (minimum to maximum open position) to maintain 55°F supply air temperature (default unit controller setting).

Y3 Demand:

Compressor 1 is energized at full capacity, supply air blower operates to maintain duct static pressure. Economizer modulates (minimum to maximum open position) to maintain 55°F supply air temperature (default unit controller setting).

¹ Outdoor air suitability is determined by the energy state of outdoor ambient (enthalpy or sensible) and its ability to achieve the desired free cooling effects. Outdoor air suitability can also be determined by a third party controller and provided to the rooftop unit via a network connection.

Unit Does Not Feature An Economizer Or Outdoor Air Is Not Suitable**Y1 Demand:**

- Compressor 1 operates at part load and supply air blower operates to maintain duct static pressure.

Y2 Demand:

Compressors 1 operates at part load with compressor 2 ON and supply air blower operates to maintain duct static pressure.

Y3 Demand:

All compressors operate at full capacity and supply air blower operates to maintain duct static pressure.

180 MODELS (3 COMPRESSORS)**VAV UNITS IN ZONING APPLICATIONS OPERATING WITH DISCHARGE AIR CONTROL (4 HEAT / 3 COOL)****SUPPLY AIR BLOWER SPEED**

Unit has the following supply air blower speed settings:

- Ventilation Speed
- Cooling Speed - Fully modular based on supply duct static pressure
- Heating Speed
- Smoke Speed (Used only in smoke removal option - not discussed)

Cooling Mode (3 Cool)

- Discharge air temperature (DAT) can be used to control unit staging.
- DAT default setpoint = 55°F. Unit will stage compressors as required to maintain the setpoint when provided with Y1 thermostat demand.
- Increasing compressor stages provides more cooling capacity while decreasing compressor stages provides less cooling capacity.

¹ Unit Features An Economizer And Outdoor Air Is Suitable**Y1 Demand:**

All compressors are off, supply air blower operates to maintain duct static pressure, economizer modulates (minimum to maximum open position) to maintain 55°F supply air temperature (default unit controller setting).

Y2 Demand:

All compressors are off, supply air blower operates to maintain duct static pressure, and economizer modulates to maintain 55°F supply air temperature. If economizer stays at maximum open for 3 minutes, compressor 1 is energized while supply air blower operates to maintain duct static pressure. After compressor 1 is energized, the economizer stays at maximum open.

Y3 Demand:

Compressor 1 and 2 are energized while supply air blower operates to maintain duct static pressure.

¹ Outdoor air suitability is determined by the energy state of outdoor ambient (enthalpy or sensible) and its ability to achieve the desired free cooling effects. Outdoor air suitability can also be determined by a third party controller and provided to the RTU via a network connection.

Unit Does Not Feature An Economizer Or Outdoor Air Is Not Suitable**Y1 Demand:**

Compressor 1 operates and supply air blower operates to maintain duct static pressure.

Y2 Demand:

Compressors 1 and 2 operate and supply air blower operates to maintain duct static pressure.

Y3 Demand:

Compressors 1, 2, and 3 operate and supply air blower operates to maintain duct static pressure.

Heating Mode (4 Heat)

- Room sensors (when connected to S-Bus) or Discharge air temperature (DAT) can be used to control up to four stages of electric heat.
- DAT default setpoint = 110°F. Unit will stage heating as required to maintain the setpoint when provided with W1 demand.
- Room sensor occupied setpoint default = 70°F. Unit will stage heating as required to maintain the setpoint.
- Increasing heat stages provides more heating capacity while decreasing heat stages provides less heating capacity.
- Blower set to Heating Speed for all stages.

210/240/300 MODELS (4 COMPRESSORS)**VAV UNITS IN ZONING APPLICATIONS OPERATING WITH DISCHARGE AIR CONTROL (4 HEAT / 4 COOL)****SUPPLY AIR BLOWER SPEED**

Unit has the following supply air blower speed settings:

- Ventilation Speed
- Cooling Speed - Fully modular based on supply duct static pressure
- Heating Speed
- Smoke Speed (Used only in smoke removal option - not discussed)

Cooling Mode (4 Cool)

- Discharge air temperature (DAT) can be used to control unit staging.
- DAT default setpoint = 55°F. Unit will stage compressors as required to maintain the setpoint when provided with Y1 thermostat demand.
- Increasing compressor stages provides more cooling capacity while decreasing compressor stages provides less cooling capacity.

¹ Unit Features An Economizer And Outdoor Air Is Suitable**Y1 Demand:**

All compressors are off, supply air blower operates to maintain duct static pressure, economizer modulates (minimum to maximum open position) to maintain 55°F supply air temperature (default unit controller setting).

Y2 Demand:

All compressors are off, supply air blower operates to maintain duct static pressure, and economizer modulates to maintain 55°F supply air temperature. If economizer stays at maximum open for 3 minutes, compressor 1 is energized while supply air blower operates to maintain duct static pressure. After compressor 1 is energized, the economizer stays at maximum open.

Y3 Demand:

Compressor 1 and 2 are energized while supply air blower operates to maintain duct static pressure.

Y4 Demand:

All compressors are energized while supply air blower operates to maintain duct static pressure.

¹ Outdoor air suitability is determined by the energy state of outdoor ambient (enthalpy or sensible) and its ability to achieve the desired free cooling effects. Outdoor air suitability can also be determined by a third party controller and provided to the RTU via a network connection.

Unit Does Not Feature An Economizer Or Outdoor Air Is Not Suitable**Y1 Demand:**

Compressor 1 operates and supply air blower operates to maintain duct static pressure.

Y2 Demand:

Compressors 1 and 2 operate and supply air blower operates to maintain duct static pressure.

Y3 Demand:

Compressors 1, 2, and 3 operate and supply air blower operates to maintain duct static pressure.

Y4 Demand:

All compressors operate and supply air blower operates to maintain duct static pressure.

**VAV UNITS IN ZONING APPLICATIONS OPERATING WITH DISCHARGE AIR CONTROL (4 HEAT / 4 COOL)
(CONTINUED)****Heating Mode (4 Heat)**

Discharge air temperature (DAT) can be used to control unit staging.

- DAT default setpoint = 110°F. Unit will stage heating as required to maintain the setpoint when provided with W1 demand.
- Increasing heat stages provides more heating capacity while decreasing heat stages provides less heating capacity.
- Blower set to Heating Speed for all stages.
- Heating Stage 1 -The first stage of mechanical heat is activated; gas valve one is in low fire mode. This is ~33% of heating capacity.
- Heating Stage 2 - The first and second stages of mechanical heat are activated; gas valves one and two are in low fire mode. This is ~66% of heating capacity.

Heating Stage 3

- Gas valve one is in high fire mode; gas valve two is in low fire mode. This is ~83% of heating capacity.

Heating Stage 4

- Gas valves one and two are in high fire mode. This is 100% of heating capacity.

Modulating Outdoor Air Damper

The minimum damper position for “occupied low blower” and “occupied high blower” is adjusted during unit setup to provide minimum fresh air requirements per ASHRAE 62.1 at the corresponding supply air blower speeds. When supply air blower is off or the unit is in unoccupied mode, the outdoor air damper is closed.

- When unit is in occupied mode and supply air blower is operating at a speed below the “midpoint” blower speed, the outdoor air damper is at minimum “low blower” position.
- When unit is in occupied mode and supply air blower is operating at a speed equal to or above the “midpoint” blower speed, the outdoor air damper is at minimum “high blower” position.

NOTE - The “midpoint” blower speed is an average of the minimum and maximum blower speed ((minimum speed + maximum speed) divided by 2).

OPTIONS / ACCESSORIES

Item Description	Order Number	Size					
		156	180	210	240	300	
COOLING SYSTEM							
Condensate Drain Trap	PVC	22H54	X	X	X	X	X
	Copper	76W27	X	X	X	X	X
Drain Pan Overflow Switch		21Z07	OX	OX	OX	OX	OX
HEATING SYSTEM							
Bottom Gas Piping Kit		85M31	X	X	X	X	X
Combustion Air Intake Extensions (order two)		89L97	X	X	X	X	X
Gas Heat Input	Low - 169,000 Btuh	Factory	O	O	O		
	Standard - 260,000 Btuh	Factory	O	O	O	O	O
	Medium - 360,000 Btuh	Factory	O	O	O	O	O
	High - 480,000 Btuh	Factory		O	O	O	O
Low Temperature Vestibule Heater	208/230V-3ph	22H58	X	X	X	X	X
	460V-3ph	22H59	X	X	X	X	X
	575V-3ph	22V43	X	X	X	X	X
LPG/Propane Conversion Kits (Order 2 kits)	Low Heat	14N28	X	X	X		
	Standard Heat	14N28	X	X	X	X	X
	Medium Heat	14N29	X	X	X	X	X
	High Heat	14N30		X	X	X	X
Stainless Steel Heat Exchanger		Factory	O	O	O	O	O
Vertical Vent Extension Kit (Order two kits)		42W16	X	X	X	X	X
BLOWER - SUPPLY AIR							
Blower Option	VAV Variable Air Volume (Without VFD Bypass Control)	Factory	O	O	O	O	O
	MSAV® Multi-Stage Air Volume (With VFD Bypass Control)	Factory	O	O	O	O	O
	MSAV® Multi-Stage Air Volume (Without VFD Bypass Control)	Factory	O	O	O	O	O
Motors	Belt Drive - 3 HP	Factory	O	O	O		
	Belt Drive - 5 HP	Factory	O	O	O	O	O
	Belt Drive - 7.5 HP	Factory		O	O	O	O
	Belt Drive - 10 HP	Factory				O	O
Drive Kits See Blower Data Tables for usage and selection	Kit #1 535-725 rpm	Factory	O	O	O		
	Kit #2 710-965 rpm	Factory	O	O	O		
	Kit #3 685-856 rpm	Factory	O	O	O	O	O
	Kit #4 850-1045 rpm	Factory	O	O	O	O	O
	Kit #5 945-1185 rpm	Factory	O	O	O	O	O
	Kit #6 850-1045 rpm	Factory		O	O	O	O
	Kit #7 945-1185 rpm	Factory		O	O	O	O
	Kit #8 1045-1285 rpm	Factory		O	O	O	O
	Kit #10 1045-1285 rpm	Factory				O	O
	Kit #11 1135-1330 rpm	Factory				O	O
	Blower Belt Auto-Tensioner	24B80	X	X	X	X	X
CABINET							
Combination Coil/Hail Guards		23U69	OX				
		23U71		OX	OX	OX	OX
Corrosion Protection		Factory	O	O	O	O	O

NOTE - Order Numbers shown are for ordering field installed accessories.

OX - Configure To Order (Factory Installed) or Field Installed

O = Configure To Order (Factory Installed)

X = Field Installed

OPTIONS / ACCESSORIES

Item Description	Order Number	Size					
		156	180	210	240	300	
CONTROLS							
Commercial Controls	LonTalk® Module Novar® LSE	54W27 Factory	OX	OX	OX	OX	OX
Dirty Filter Switch		53W68	OX	OX	OX	OX	OX
Fresh Air Tempering		21Z08	OX	OX	OX	OX	OX
Smoke Detector - Supply or Return (Power board and one sensor)		22H56	OX	OX	OX	OX	OX
Smoke Detector - Supply and Return (Power board and two sensors)		22H57	OX	OX	OX	OX	OX
INDOOR AIR QUALITY							
Air Filters							
Healthy Climate® High Efficiency Air Filters 24 x 24 x 2 (Order 6 per unit)	MERV 8	54W67	OX	OX	OX	OX	OX
	MERV 13	52W40	OX	OX	OX	OX	OX
	MERV 16	21U42	X	X	X	X	X
Replacement Media Filter With Metal Mesh Frame (includes non-pleated filter media)		44N61	X	X	X	X	X
Indoor Air Quality (CO₂) Sensors							
Sensor - Wall-mount, off-white plastic cover with LCD display		24C58	X	X	X	X	X
Sensor - Wall-mount, off-white plastic cover, no display		23V86	X	X	X	X	X
Sensor - Black plastic case, LCD display, rated for plenum mounting		87N52	X	X	X	X	X
Sensor - Black plastic case, no display, rated for plenum mounting		23V87	X	X	X	X	X
CO ₂ Sensor Duct Mounting Kit - for downflow applications		23Y47	X	X	X	X	X
Aspiration Box - for duct mounting non-plenum rated CO ₂ sensors (24C58)		90N43	X	X	X	X	X
Needlepoint Bipolar Ionization (NPBI)							
Needlepoint Bipolar Ionization (NPBI) Kit		21U37	X	X	X		
		21U38				X	
		21U39					X
UVC Germicidal Light Kit							
¹ Healthy Climate® UVC Light Kit (110/230V-1ph)		21A94	X	X	X	X	X
Step-Down Transformers	460V primary, 230V secondary	10H20	X	X	X	X	X
	575V primary, 230V secondary	10H21	X	X	X	X	X
ELECTRICAL							
Voltage 60 Hz	208/230V - 3 phase	Factory	O	O	O	O	O
	460V - 3 phase	Factory	O	O	O	O	O
	575V - 3 phase	Factory	O	O	O	O	O
HACR Circuit Breakers		Factory	O	O	O	O	O
² Short-Circuit Current Rating (SCCR) of 100kA (includes Phase/Voltage Detection)		Factory	O	O	O	O	O
² Disconnect Switch (see Disconnect Table for usage, page 54)	80 amp	54W88	OX	OX	OX	OX	OX
	150 amp	54W89	OX	OX	OX	OX	OX
	250 amp	90W82					OX
GFI Service Outlets	15 amp non-powered, field-wired (208/230V, 460V only)	74M70	OX	OX	OX	OX	OX
	³ 15 amp factory-wired and powered (208/230V, 460V only)	Factory	O	O	O	O	O
	⁴ 20 amp non-powered, field-wired (208/230V, 460V, 575V)	67E01	X	X	X	X	X
	⁴ 20 amp non-powered, field-wired (575V)	Factory	O	O	O	O	O
Weatherproof Cover for GFI		10C89	X	X	X	X	X

¹ 1Lamps operate on 110-230V single-phase power supply. Step-down transformer may be ordered separately for 460V and 575V units. Alternately, 110V power supply may be used to directly power the UVC ballast(s).

² Disconnect Switch is furnished and factory installed with SCCR option.

³ Unit powered GFI Service Outlets are not available with SCCR option.

Disconnect Switch or Circuit Breaker is required with unit powered GFI Service Outlets.

⁴ Canada requires a minimum 20 amp circuit. Select 20 amp, non-powered, field wired GFI.

NOTE - Order Numbers shown are for ordering field installed accessories.

OX - Configure To Order (Factory Installed) or Field Installed

O = Configure To Order (Factory Installed)

X = Field Installed

OPTIONS / ACCESSORIES

Item Description	Order Number	Size				
		156	180	210	240	300
ECONOMIZER						
High Performance Economizer (Approved for California Title 24 Building Standards AMCA Class 1A Certified)						
High Performance Economizer (Downflow or Horizontal) Includes Economizer Dampers with Outdoor Air Hood Downflow Applications - Use furnished Outdoor Air Hood - Order Downflow Barometric Relief Dampers with Exhaust Hood separately Horizontal Applications - Use furnished Outdoor Air Hood - Order Horizontal Barometric Relief Dampers with Exhaust Hood separately	22J18	OX	OX	OX	OX	OX
Economizer Controls						
Differential Enthalpy (Not for Title 24)	Order 2 21Z09	OX	OX	OX	OX	OX
Sensible Control	Sensor is Furnished Factory	O	O	O	O	O
Single Enthalpy (Not for Title 24)	21Z09	OX	OX	OX	OX	OX
Global Control	Sensor Field Provided Factory	O	O	O	O	O
Building Pressure Control	13J77	X	X	X	X	X
Outdoor Air CFM Control	13J76	X	X	X	X	X
Barometric Relief Dampers With Exhaust Hood						
Downflow Barometric Relief Dampers	54W78	OX	OX	OX	OX	OX
Horizontal Barometric Relief Dampers	16K99	X	X	X	X	X
OUTDOOR AIR						
Outdoor Air Dampers With Outdoor Air Hood						
Motorized	22J27	OX	OX	OX	OX	OX
Manual	13U05	X	X	X	X	X
⁵ POWER EXHAUST (DOWNFLOW APPLICATIONS ONLY)						
Standard Static, SCCR Rated	208/230V 22H90	OX	OX	OX	OX	OX
	460V 22H91	OX	OX	OX	OX	OX
	575V 22V34	OX	OX	OX	OX	OX
HUMIDITROL® CONDENSER REHEAT OPTION (MSAV®) MODELS ONLY						
Humiditrol Dehumidification Option	Factory	O	O	O	O	O

⁵ Field installed Power Exhaust requires Economizer with Outdoor Air Hood and Downflow Barometric Relief Dampers with Exhaust Hood. Must be ordered separately.

NOTE - Order Numbers shown are for ordering field installed accessories.

OX - Configure To Order (Factory Installed) or Field Installed

O = Configure To Order (Factory Installed)

X = Field Installed

OPTIONS / ACCESSORIES

Item Description	Order Number	Size				
		156	180	210	240	300
ROOF CURBS						
Hybrid Roof Curbs, Downflow						
8 in. height	11F58	X	X	X	X	X
14 in. height	11F59	X	X	X	X	X
18 in. height	11F60	X	X	X	X	X
24 in. height	11F61	X	X	X	X	X
Adjustable Pitch Curb						
14 in. height	43W26	X	X	X	X	X
Standard Roof Curbs, Horizontal - Requires Horizontal Return Air Panel Kit						
26 in. height - slab applications	11T89	X	X	X	X	
30 in. height - slab applications	11T90					X
37 in. height - rooftop applications	11T96	X	X	X	X	
41 in. height - rooftop applications	11T97					X
Insulation Kit For Standard Horizontal Roof Curbs						
For 26 in. Curb	73K32	X	X	X	X	
For 30 in. Curb	73K33					X
For 37 in. Curb	73K34	X	X	X	X	
For 41 in. Curb	73K35					X
Horizontal Return Air Panel Kit						
Required for Horizontal Applications with Roof Curb	87M00	X	X	X	X	X
CEILING DIFFUSERS						
Step-Down - Order one	RTD11-185S	13K63	X	X		
	RTD11-275S	13K64			X	X
Flush - Order one	FD11-185S	13K58	X	X		
	FD11-275S	13K59			X	X
Transitions (Supply and Return) - Order one	C1DIFF33C-1	12X68	X	X		
	C1DIFF34C-1	12X70			X	X

NOTE - Order Numbers shown are for ordering field installed accessories.

OX - Configure To Order (Factory Installed) or Field Installed

O = Configure To Order (Factory Installed)

X = Field Installed

SPECIFICATIONS

13 TON

Model		LGT156H5M	LGT156H5V
Nominal Tonnage		13 Ton	13 Ton
Efficiency Type		High	High
Blower Type		MSAV® Multi-Stage Air Volume	VAV Variable Air Volume
Cooling Performance	Gross Cooling Capacity (Btuh)	152,000	152,000
	¹ Net Cooling Capacity (Btuh)	148,000	148,000
	¹ AHRI Rated Air Flow (cfm)	5800	5800
	¹ IEER (Btuh/Watt)	15.4	15
	¹ EER (Btuh/Watt)	12	12
	Total Unit Power (kW)	12.3	12.3
Sound Rating Number	dBA	86	86
Refrigerant Charge	Refrigerant Type	R-454B	R-454B
	Without Reheat Option	Circuit 1	9 lbs. 0 oz.
		Circuit 2	7 lbs. 10 oz.
	With Reheat Option	Circuit 1	9 lbs. 0 oz.
		Circuit 2	7 lbs. 15 oz.
Gas Heat Available		See page 39	
Compressor Type (number)		Two-Stage Scroll (1), Single-Stage Scroll (1)	
Outdoor Coils	Net face area - ft. ² (total)	41.4	41.4
	Rows	1	1
	Fins - in.	23	23
Outdoor Coil Fans	Motor HP (number and type)	1/3 (1 ECM) (2 PSC)	1/3 (1 ECM) (2 PSC)
	Rpm	1075	1075
	Watts (total)	1100	1100
	Diameter (Number) - in.	3 (24)	3 (24)
	Blades	3	3
	Total Air volume - cfm	12,000	12,000
Indoor Coils	Net face area - ft. ² (total)	21.4	21.4
	Tube diameter - in.	3/8	3/8
	Rows	3	3
	Fins - in.	14	14
	Condensate drain size (NPT) - in.	(1) 1	(1) 1
	Expansion device type	Balanced Port Thermostatic Expansion Valve, removable power head	
³ Indoor Blower and Drive Selection	Nominal motor HP	3, 5	
	Maximum usable motor HP (US)	3.45, 5.75	
	Drive kit number	3 HP	
		Kit 1 535-725 rpm	
		Kit 2 710-965 rpm	
		5 HP	
		Kit 3 - 685-856 rpm	
Kit 4 850-1045 rpm			
	Kit 5 945-1185 rpm		
	Wheel (Number) diameter x width - in.	(2) 15 x 15 in.	(2) 15 x 15 in.
Filters	Type of filter	MERV 4, Disposable	
	Number and size - in.	(6) 24 x 24 x 2	
Line voltage data (Volts-Phase-Hz)		208/230-3-60, 460-3-60, 575-3-60	

NOTE - Net capacity includes evaporator blower motor heat deduction. Gross capacity does not include evaporator blower motor heat deduction.

¹ AHRI Certified to AHRI Standard 340/360; 95°F outdoor air temperature and 80°F db/67°F wb entering evaporator air; minimum external duct static pressure.

² Integrated Energy Efficiency Ratio tested according to AHRI Standard 340/360.

³ Using total air volume and system static pressure requirements determine from blower performance tables rpm and motor output required. Maximum usable output of motors furnished are shown. In Canada, nominal motor output is also maximum usable motor output. If motors of comparable output are used, be sure to keep within the service factor limitations outlined on the motor nameplate.

NOTE – All units are limited to a motor service factor of 1.0.

SPECIFICATIONS **15 TON**

Model		LGT180H5M	LGT180H5V	
Nominal Tonnage		15 Ton	15 Ton	
Efficiency Type		High	High	
Blower Type		MSAV® Multi-Stage Air Volume	VAV Variable Air Volume	
Cooling Performance	Gross Cooling Capacity (Btuh)	176,000	176,000	
	¹ Net Cooling Capacity (Btuh)	172,000	172,000	
	¹ AHRI Rated Air Flow (cfm)	5000	5000	
	¹ IEER (Btuh/Watt)	15.4	15	
	¹ EER (Btuh/Watt)	12	12	
	Total Unit Power (kW)	14.3	14.3	
Sound Rating Number	dBA	93	93	
Refrigerant Charge	Refrigerant Type	R-454B	R-454B	
	Without Reheat Option	Circuit 1	5 lbs. 14 oz.	5 lbs. 14 oz.
		Circuit 2	5 lbs. 8 oz.	5 lbs. 8 oz.
		Circuit 3	5 lbs. 0 oz.	5 lbs. 0 oz.
	With Reheat Option	Circuit 1	6 lbs. 7 oz.	---
		Circuit 2	6 lbs. 1 oz.	---
		Circuit 3	6 lbs. 0 oz.	---
Gas Heat Available		See page 39		
Compressor Type (number)		Scroll (3)	Scroll (3)	
Outdoor Coils	Net face area - ft. ² (total)	55.2	55.2	
	Rows	1	1	
	Fins - in.	23	23	
Outdoor Coil Fans	Motor HP (number and type)	1/3 (2 ECM) (2 PSC)	1/3 (2 ECM) (2 PSC)	
	Rpm	1075	1075	
	Watts (total)	1500	1500	
	Diameter (Number) - in.	(4) 24	(4) 24	
	Blades	3	3	
	Total Air volume - cfm	16,000	16,000	
Indoor Coils	Net face area - ft. ² (total)	21.4	21.4	
	Tube diameter - in.	3/8	3/8	
	Rows	3	3	
	Fins - in.	14	14	
	Condensate drain size (NPT) - in.	(1) 1	(1) 1	
	Expansion device type	Balanced Port Thermostatic Expansion Valve, removable power head		
³ Indoor Blower and Drive Selection	Nominal motor HP	3, 5, 7.5		
	Maximum usable motor HP (US)	3.45, 5.75		
	Drive kit number	3 HP		
		Kit 1 535-725 rpm		
		Kit 2 710-965 rpm		
		5 HP		
	Kit 3 685-856 rpm			
	Kit 4 850-1045 rpm			
Kit 5 945-1185 rpm				
7.5 HP				
Kit 6 850-1045 rpm				
Kit 7 945-1185 rpm				
Kit 8 1045-1285 rpm				
	Wheel (Number) diameter x width - in.	(2) 15 x 15 in.	(2) 15 x 15 in.	
Filters	Type of filter	MERV 4, Disposable		
	Number and size - in.	(6) 24 x 24 x 2		
Line voltage data (Volts-Phase-Hz)		208/230-3-60, 460-3-60, 575-3-60		

NOTE - Net capacity includes evaporator blower motor heat deduction. Gross capacity does not include evaporator blower motor heat deduction.

¹ AHRI Certified to AHRI Standard 340/360; 95°F outdoor air temperature and 80°F db/67°F wb entering evaporator air; minimum external duct static pressure.

² Integrated Energy Efficiency Ratio tested according to AHRI Standard 340/360.

³ Using total air volume and system static pressure requirements determine from blower performance tables rpm and motor output required. Maximum usable output of motors furnished are shown. In Canada, nominal motor output is also maximum usable motor output. If motors of comparable output are used, be sure to keep within the service factor limitations outlined on the motor nameplate.

NOTE – All units are limited to a motor service factor of 1.0.

SPECIFICATIONS **17.5 TON**

Model		LGT210H5M	LGT210H5V
Nominal Tonnage		17.5 Ton	17.5 Ton
Efficiency Type		High	High
Blower Type		MSAV® Multi-Stage Air Volume	VAV Variable Air Volume
Cooling Performance	Gross Cooling Capacity (Btuh)	206,000	206,000
	¹ Net Cooling Capacity (Btuh)	200,000	200,000
	¹ AHRI Rated Air Flow (cfm)	6125	6125
	¹ IEER (Btuh/Watt)	16.0	15.5
	¹ EER (Btuh/Watt)	12	12
	Total Unit Power (kW)	16.7	16.7
Sound Rating Number	dBA	94	94
Refrigerant Charge	Refrigerant Type	R-454B	R-454B
	Without Reheat Option		
	Circuit 1	5 lbs. 11 oz.	5 lbs. 11 oz.
	Circuit 2	5 lbs. 14 oz.	5 lbs. 14 oz.
	Circuit 3	5 lbs. 3 oz.	5 lbs. 3 oz.
	Circuit 4	5 lbs. 5 oz.	5 lbs. 5 oz.
	With Reheat Option		
	Circuit 1	6 lbs. 0 oz.	---
	Circuit 2	6 lbs. 11 oz.	---
	Circuit 3	5 lbs. 4 oz.	---
	Circuit 4	5 lbs. 8 oz.	---
Gas Heat Available		See page 39	
Compressor Type (number)		Scroll (4)	Scroll (4)
Outdoor Coils	Net face area - ft. ² (total)	55.2	55.2
	Rows	1	1
	Fins - in.	23	23
Outdoor Coil Fans	Motor HP (number and type)	1/3 (2 ECM) (2 PSC)	1/3 (2 ECM) (2 PSC)
	Rpm	1075	1075
	Watts (total)	1500	1500
	Diameter (Number) - in.	(4) 24	(4) 24
	Blades	3	3
	Total Air volume - cfm	16,000	16,000
Indoor Coils	Net face area - ft. ² (total)	21.4	21.4
	Tube diameter - in.	3/8	3/8
	Rows	4	3
	Fins - in.	14	14
	Condensate drain size (NPT) - in.	(1) 1	(1) 1
	Expansion device type	Balanced Port Thermostatic Expansion Valve, removable power head	
³ Indoor Blower and Drive Selection	Nominal motor HP	3, 5, 7.5	
	Maximum usable motor HP (US)	3.45, 5.75	
	Drive kit number	3 HP Kit 1 535-725 rpm Kit 2 710-965 rpm	
		5 HP Kit 3 685-856 rpm Kit 4 850-1045 rpm Kit 5 945-1185 rpm	
		7.5 HP Kit 6 850-1045 rpm Kit 7 945-1185 rpm Kit 8 1045-1285 rpm	
	Wheel (Number) diameter x width - in.	(2) 15 x 15 in.	(2) 15 x 15 in.
Filters	Type of filter	MERV 4, Disposable	
	Number and size - in.	(6) 24 x 24 x 2	
Line voltage data (Volts-Phase-Hz)		208/230-3-60, 460-3-60, 575-3-60	

NOTE - Net capacity includes evaporator blower motor heat deduction. Gross capacity does not include evaporator blower motor heat deduction.

¹ AHRI Certified to AHRI Standard 340/360; 95°F outdoor air temperature and 80°F db/67°F wb entering evaporator air; minimum external duct static pressure.

² Integrated Energy Efficiency Ratio tested according to AHRI Standard 340/360.

³ Using total air volume and system static pressure requirements determine from blower performance tables rpm and motor output required. Maximum usable output of motors furnished are shown. In Canada, nominal motor output is also maximum usable motor output. If motors of comparable output are used, be sure to keep within the service factor limitations outlined on the motor nameplate.

NOTE - All units are limited to a motor service factor of 1.0.

SPECIFICATIONS
20 TON

Model		LGT240H5M	LGT240H5V
Nominal Tonnage		20 Ton	20 Ton
Efficiency Type		High	High
Blower Type		MSAV® Multi-Stage Air Volume	VAV Variable Air Volume
Cooling Performance	Gross Cooling Capacity (Btuh)	236,000	236,000
	¹ Net Cooling Capacity (Btuh)	228,000	228,000
	¹ AHRI Rated Air Flow (cfm)	6250	6250
	¹ IEER (Btuh/Watt)	15.4	15.2
	¹ EER (Btuh/Watt)	12	12
	Total Unit Power (kW)	19	19
Sound Rating Number	dBA	94	94
Refrigerant Charge	Refrigerant Type	R-454B	R-454B
	Without Reheat Option		
	Circuit 1	6 lbs. 0 oz.	6 lbs. 0 oz.
	Circuit 2	6 lbs. 12 oz.	6 lbs. 12 oz.
	Circuit 3	5 lbs. 0 oz.	5 lbs. 0 oz.
	Circuit 4	5 lbs. 5 oz.	5 lbs. 5 oz.
	With Reheat Option		
	Circuit 1	6 lbs. 8 oz.	---
	Circuit 2	6 lbs. 8 oz.	---
	Circuit 3	5 lbs. 4 oz.	---
	Circuit 4	5 lbs. 12 oz.	---
Gas Heat Available		See page 39	
Compressor Type (number)		Scroll (4)	Scroll (4)
Outdoor Coils	Net face area - ft. ² (total)	55.2	55.2
	Rows	1	1
	Fins - in.	23	23
Outdoor Coil Fans	Motor HP (number and type)	1/3 (2 ECM) (4 PSC)	1/3 (2 ECM) (4 PSC)
	Rpm	1075	1075
	Watts (total)	1075 - 1950	1075 - 1950
	Diameter (Number) - in.	(6) 24	(6) 24
	Blades	3	3
	Total Air volume - cfm	20,000	20,000
Indoor Coils	Net face area - ft. ² (total)	21.4	21.4
	Tube diameter - in.	3/8	3/8
	Rows	4	4
	Fins - in.	14	14
	Condensate drain size (NPT) - in.	(1) 1	(1) 1
	Expansion device type	Balanced Port Thermostatic Expansion Valve, removable power head	
³ Indoor Blower and Drive Selection	Nominal motor HP	5, 7.5, 10	
	Maximum usable motor HP (US)	5.75, 8.62, 11.5	
	Drive kit number	5 HP Kit 3 685-856 rpm Kit 4 850-1045 rpm Kit 5 945-1185 rpm 7.5 HP Kit 6 850-1045 rpm Kit 7 945-1185 rpm Kit 8 1045-1285 rpm 10 HP Kit 7 945-1185 rpm Kit 10 1045-1285 rpm Kit 11 1135-1330 rpm	
	Wheel (Number) diameter x width - in.	(2) 15 x 15 in.	(2) 15 x 15 in.
Filters	Type of filter	MERV 4, Disposable	
	Number and size - in.	(6) 24 x 24 x 2	
Line voltage data (Volts-Phase-Hz)		208/230-3-60, 460-3-60, 575-3-60	

NOTE - Net capacity includes evaporator blower motor heat deduction. Gross capacity does not include evaporator blower motor heat deduction.

¹ AHRI Certified to AHRI Standard 340/360; 95°F outdoor air temperature and 80°F db/67°F wb entering evaporator air; minimum external duct static pressure.

² Integrated Energy Efficiency Ratio tested according to AHRI Standard 340/360.

³ Using total air volume and system static pressure requirements determine from blower performance tables rpm and motor output required. Maximum usable output of motors furnished are shown. In Canada, nominal motor output is also maximum usable motor output. If motors of comparable output are used, be sure to keep within the service factor limitations outlined on the motor nameplate.

NOTE - All units are limited to a motor service factor of 1.0.

SPECIFICATIONS

25 TON

Model	LGT300H5M		LGT300H5V	
Nominal Tonnage	25 Ton		25 Ton	
Efficiency Type	High		High	
Blower Type	MSAV® Multi-Stage Air Volume		VAV Variable Air Volume	
Cooling Performance	Gross Cooling Capacity (Btuh)	281,000	281,000	
	¹ Net Cooling Capacity (Btuh)	270,000	270,000	
	¹ AHRI Rated Air Flow (cfm)	7500	7500	
	¹ IEER (Btuh/Watt)	14.3	14	
	¹ EER (Btuh/Watt)	10.6	10.6	
	Total Unit Power (kW)	25.5	25.5	
Sound Rating Number	dBA	94	94	
Refrigerant Charge	Refrigerant Type	R-454B		R-454B
	Without Reheat Option	Circuit 1	5 lbs. 15 oz.	5 lbs. 15 oz.
		Circuit 2	5 lbs. 7 oz.	5 lbs. 7 oz.
		Circuit 3	5 lbs. 5 oz.	5 lbs. 5 oz.
		Circuit 4	5 lbs. 6 oz.	5 lbs. 6 oz.
	With Reheat Option	Circuit 1	6 lbs. 6 oz.	---
		Circuit 2	6 lbs. 2 oz.	---
		Circuit 3	5 lbs. 2 oz.	---
		Circuit 4	5 lbs. 12 oz.	---
Gas Heat Available	See page 39			
Compressor Type (number)	Scroll (4)		Scroll (4)	
Outdoor Coils	Net face area - ft. ² (total)	55.2	55.2	
	Rows	1	1	
	Fins - in.	23	23	
Outdoor Coil Fans	Motor HP (number and type)	1/3 (2 ECM) (4 PSC)	1/3 (2 ECM) (4 PSC)	
	Rpm	1075	1075	
	Watts (total)	1075 - 1950	1075 - 1950	
	Diameter (Number) - in.	(6) 24	(6) 24	
	Blades	3	3	
	Total Air volume - cfm	20,000	20,000	
Indoor Coils	Net face area - ft. ² (total)	21.4	21.4	
	Tube diameter - in.	3/8	3/8	
	Rows	4	4	
	Fins - in.	14	14	
	Condensate drain size (NPT) - in.	(1) 1	(1) 1	
	Expansion device type	Balanced Port Thermostatic Expansion Valve, removable power head		
³ Indoor Blower and Drive Selection	Nominal motor HP	5, 7.5, 10		
	Maximum usable motor HP (US)	5.75, 8.62, 11.5		
	Drive kit number	5 HP Kit 3 685-856 rpm Kit 4 850-1045 rpm Kit 5 945-1185 rpm 7.5 HP Kit 6 850-1045 rpm Kit 7 945-1185 rpm Kit 8 1045-1285 rpm 10 HP Kit 7 945-1185 rpm Kit 10 1045-1285 rpm Kit 11 1135-1330 rpm		
	Wheel (Number) diameter x width - in.	(2) 15 x 15 in.	(2) 15 x 15 in.	
Filters	Type of filter	MERV 4, Disposable		
	Number and size - in.	(6) 24 x 24 x 2		
Line voltage data (Volts-Phase-Hz)	208/230-3-60, 460-3-60, 575-3-60			

NOTE - Net capacity includes evaporator blower motor heat deduction. Gross capacity does not include evaporator blower motor heat deduction.

¹ AHRI Certified to AHRI Standard 340/360; 95°F outdoor air temperature and 80°F db/67°F wb entering evaporator air; minimum external duct static pressure.

² Integrated Energy Efficiency Ratio tested according to AHRI Standard 340/360.

³ Using total air volume and system static pressure requirements determine from blower performance tables rpm and motor output required. Maximum usable output of motors furnished are shown. In Canada, nominal motor output is also maximum usable motor output. If motors of comparable output are used, be sure to keep within the service factor limitations outlined on the motor nameplate.

NOTE - All units are limited to a motor service factor of 1.0.

SPECIFICATIONS GAS HEAT

Model	LGT156 LGT180 LGT210	LGT156 LGT180 LGT210 LGT240 LGT300	LGT180 LGT210 LGT240 LGT300		
Heat Input Type	Low (L)	Standard (S)	Medium (M)	High (H)	
Number of Gas Heat Stages	One	¹ Two	¹ Two	¹ Two	
¹ Gas Heating Performance	Input - Btuh				
	First Stage	169,000	85,000	117,000	156,000
	Second Stage	---	169,000	234,000	312,000
	Third Stage	---	214,000	297,000	396,000
	Fourth Stage	---	260,000	360,000	480,000
	Output - Btuh				
	First Stage	135,000	---	---	---
	Second Stage	---	---	---	---
Third Stage	---	---	---	---	
Fourth Stage	---	211,000	292,000	389,000	
Temperature Rise Range - °F	First Stage	15-45	15-45	30-60	40-70
	Second Stage	---	---	---	---
Minimum Air Volume - cfm	3000	4500	4500	5125	
Thermal Efficiency	80%	81%	81%	81%	
Gas Supply Connections	1 in. NPT	1 in. NPT	1 in. NPT	1 in. NPT	
Recommended Gas Supply Pressure - in. w.g.	Natural	7	7	7	7
	LPG/Propane	11	11	11	11
Gas Supply Pressure Range	Min./Max. (Natural)	4.7 - 10.5 in. w.g.			
	Min./Max. (LPG)	10.8 - 13.5 in.w.g.			

¹ Two-stage heat models can be operated with four stages of gas heating when controlled in either zone sensor, Discharge Air Control, or fresh air tempering mode on the Lennox® CORE unit controller.

HIGH ALTITUDE DERATE

NOTE - Units may be installed at altitudes up to 2000 feet above sea level without any modification.

At altitudes above 2000 feet, units must be derated to match gas manifold pressures shown in table below.

At altitudes above 4500 feet units must be derated 4% for each 1000 feet above sea level.

NOTE - This is the only permissible derate for these units.

Refer to the Installation Instructions for more detailed information.

ONE STAGE HEAT

No Adjustment Required

TWO STAGE HEAT

Heat Input Type	Altitude Feet	Gas Manifold Pressure - in. w.g.		Input Rate (Btuh)	
		Natural Gas	LPG/Propane Gas	First Stage	Second Stage
Standard (2 stage)	2001 - 4500	1.6 / 3.1	4.4 / 8.9	169,000	239,000
Medium (2 stage)	2001 - 4500	1.6 / 3.1	4.4 / 8.9	234,000	331,000
High (2 stage)	2001 - 4500	1.6 / 3.1	4.4 / 8.9	312,000	442,000

FOUR STAGE HEAT

¹ Heat Input Type	Altitude Feet	Gas Manifold Pressure - in. w.g.		Input Rate (Btuh)			
		Natural Gas	LPG/Propane Gas	First Stage	Second Stage	Third Stage	Fourth Stage
Standard (4 stage)	2001 - 4500	1.6 / 3.1	4.4 / 8.9	85,000	169,000	204,000	239,000
Medium (4 stage)	2001 - 4500	1.6 / 3.1	4.4 / 8.9	117,000	234,000	283,000	331,000
High (4 stage)	2001 - 4500	1.6 / 3.1	4.4 / 8.9	156,000	312,000	377,000	442,000

¹ Four-Stage Gas Heating is field configured.

RATINGS

NOTE – For Temperatures and Capacities not shown in tables, see bulletin – Cooling Unit Rating Table Correction Factor Data in Miscellaneous Engineering Data section.

13 TON - HIGH EFFICIENCY LGT156H5M/V (1 COMPRESSOR - PART LOAD)

Entering Wet Bulb Temperature	Total Air Volume	Outdoor Air Temperature Entering Outdoor Coil																			
		65°F					75°F					85°F					95°F				
		Total Cool Cap.	Comp. Motor Input	Sensible To Total Ratio (S/T)			Total Cool Cap.	Comp. Motor Input	Sensible To Total Ratio (S/T)			Total Cool Cap.	Comp. Motor Input	Sensible To Total Ratio (S/T)			Total Cool Cap.	Comp. Motor Input	Sensible To Total Ratio (S/T)		
				Dry Bulb					Dry Bulb					Dry Bulb					Dry Bulb		
cfm	kBtuh	kW	75°F	80°F	85°F	kBtuh	kW	75°F	80°F	85°F	kBtuh	kW	75°F	80°F	85°F	kBtuh	kW	75°F	80°F	85°F	
63°F	1500	54.8	1.92	0.7	0.84	0.97	51.9	2.23	0.71	0.85	0.99	48.8	2.57	0.71	0.87	1	45.4	2.97	0.72	0.89	1
	1800	57.9	1.89	0.74	0.9	1	55	2.21	0.75	0.91	1	51.6	2.55	0.76	0.93	1	48.2	2.95	0.77	0.96	1
	2100	60.3	1.87	0.78	0.95	1	57.4	2.19	0.79	0.97	1	54.3	2.53	0.81	0.99	1	50.7	2.93	0.82	1	1
67°F	1500	58.3	1.89	0.56	0.68	0.8	55.5	2.21	0.55	0.69	0.82	52.3	2.55	0.55	0.69	0.83	48.8	2.95	0.55	0.7	0.85
	1800	61.6	1.87	0.58	0.72	0.86	58.7	2.19	0.58	0.73	0.88	55.2	2.53	0.58	0.74	0.9	51.6	2.93	0.59	0.75	0.92
	2100	64.3	1.86	0.61	0.76	0.92	61	2.17	0.61	0.77	0.94	57.4	2.51	0.61	0.78	0.96	53.3	2.91	0.62	0.8	0.98
71°F	1500	62.1	1.87	0.42	0.54	0.66	59.2	2.18	0.41	0.54	0.67	55.9	2.52	0.4	0.54	0.67	52.3	2.92	0.39	0.54	0.68
	1800	65.7	1.85	0.43	0.57	0.7	62.5	2.16	0.42	0.57	0.71	58.9	2.5	0.41	0.57	0.71	54.8	2.9	0.41	0.58	0.73
	2100	68.3	1.83	0.44	0.6	0.74	64.9	2.14	0.44	0.6	0.75	61.1	2.48	0.43	0.61	0.76	56.9	2.89	0.42	0.62	0.78

13 TON - HIGH EFFICIENCY LGT156H5M/V (2 COMPRESSORS - PART LOAD / FULL LOAD)

Entering Wet Bulb Temperature	Total Air Volume	Outdoor Air Temperature Entering Outdoor Coil																			
		85°F					95°F					105°F					115°F				
		Total Cool Cap.	Comp. Motor Input	Sensible To Total Ratio (S/T)			Total Cool Cap.	Comp. Motor Input	Sensible To Total Ratio (S/T)			Total Cool Cap.	Comp. Motor Input	Sensible To Total Ratio (S/T)			Total Cool Cap.	Comp. Motor Input	Sensible To Total Ratio (S/T)		
				Dry Bulb					Dry Bulb					Dry Bulb					Dry Bulb		
cfm	kBtuh	kW	75°F	80°F	85°F	kBtuh	kW	75°F	80°F	85°F	kBtuh	kW	75°F	80°F	85°F	kBtuh	kW	75°F	80°F	85°F	
63°F	3000	122.6	7.1	0.68	0.8	0.93	115	8.1	0.69	0.82	0.94	106.7	9.24	0.7	0.84	0.97	98.3	10.5	0.69	0.86	0.99
	4000	131	7.11	0.74	0.9	1	123.7	8.13	0.75	0.91	1	115.1	9.24	0.76	0.94	1	106.9	10.53	0.78	0.96	1
	5000	139	7.1	0.8	0.98	1	131.1	8.13	0.81	0.99	1	123	9.26	0.85	1	1	114.2	10.51	0.87	1	1
67°F	3000	130.3	7.1	0.53	0.66	0.78	122.9	8.12	0.53	0.66	0.79	114.1	9.23	0.53	0.67	0.8	105.7	10.52	0.53	0.68	0.82
	4000	140.2	7.1	0.57	0.72	0.87	132.1	8.12	0.57	0.73	0.88	123.2	9.25	0.57	0.74	0.91	113	10.51	0.59	0.77	0.93
	5000	146.7	7.09	0.62	0.79	0.95	137.9	8.12	0.62	0.8	0.97	128.5	9.26	0.62	0.82	0.99	117.9	10.52	0.62	0.85	1
71°F	3000	138.4	7.09	0.4	0.53	0.64	130.2	8.1	0.39	0.52	0.64	122.2	9.24	0.37	0.52	0.65	112.5	10.49	0.37	0.52	0.65
	4000	148.9	7.08	0.42	0.55	0.7	139.9	8.1	0.41	0.56	0.7	131	9.24	0.41	0.56	0.73	120.7	10.52	0.41	0.57	0.73
	5000	155.6	7.08	0.45	0.61	0.76	146.5	8.11	0.45	0.62	0.78	136.7	9.27	0.44	0.61	0.8	126.3	10.54	0.43	0.63	0.83

13 TON - HIGH EFFICIENCY LGT156H5M (2 COMPRESSORS - FULL LOAD)

Entering Wet Bulb Temperature	Total Air Volume	Outdoor Air Temperature Entering Outdoor Coil																			
		85°F					95°F					105°F					115°F				
		Total Cool Cap.	Comp. Motor Input	Sensible To Total Ratio (S/T)			Total Cool Cap.	Comp. Motor Input	Sensible To Total Ratio (S/T)			Total Cool Cap.	Comp. Motor Input	Sensible To Total Ratio (S/T)			Total Cool Cap.	Comp. Motor Input	Sensible To Total Ratio (S/T)		
				Dry Bulb					Dry Bulb					Dry Bulb					Dry Bulb		
cfm	kBtuh	kW	75°F	80°F	85°F	kBtuh	kW	75°F	80°F	85°F	kBtuh	kW	75°F	80°F	85°F	kBtuh	kW	75°F	80°F	85°F	
63°F	4160	146.5	8.33	0.72	0.87	0.97	138.9	9.48	0.73	0.87	0.99	130	10.75	0.74	0.89	1	120.8	12.13	0.75	0.91	1
	5200	154.8	8.37	0.77	0.92	1	146.3	9.53	0.79	0.94	1	137.9	10.81	0.8	0.96	1	128.4	12.21	0.82	0.99	1
	6240	162	8.42	0.83	0.98	1	153.5	9.57	0.85	1	1	144.4	10.85	0.85	1	1	134.6	12.25	0.89	1	1
67°F	4160	156.3	8.38	0.55	0.69	0.82	147.8	9.53	0.55	0.71	0.84	138.4	10.79	0.55	0.71	0.86	127.7	12.19	0.56	0.72	0.88
	5200	164.4	8.44	0.6	0.74	0.9	154.6	9.57	0.6	0.76	0.92	144	10.83	0.6	0.77	0.94	133	12.22	0.61	0.8	0.96
	6240	169.4	8.46	0.62	0.81	0.96	159.2	9.6	0.64	0.82	0.98	148.3	10.86	0.65	0.84	1	137.1	12.25	0.65	0.89	1
71°F	4160	165.5	8.44	0.42	0.55	0.67	156.7	9.58	0.41	0.55	0.68	146.5	10.84	0.4	0.56	0.69	136.1	12.24	0.39	0.55	0.7
	5200	173.7	8.49	0.43	0.59	0.72	163.9	9.63	0.41	0.59	0.74	153	10.89	0.42	0.6	0.76	141.7	12.28	0.4	0.61	0.78
	6240	179.7	8.52	0.44	0.62	0.8	168.7	9.66	0.44	0.63	0.81	158.2	10.93	0.44	0.63	0.83	146.2	12.32	0.43	0.64	0.85

RATINGS

NOTE – For Temperatures and Capacities not shown in tables, see bulletin – Cooling Unit Rating Table Correction Factor Data in Miscellaneous Engineering Data section.

15 TON - HIGH EFFICIENCY LGT180H5M/V (1 COMPRESSOR - PART LOAD)

Entering Wet Bulb Temperature	Total Air Volume	Outdoor Air Temperature Entering Outdoor Coil																			
		65°F					75°F					85°F					95°F				
		Total Cool Cap.	Comp. Motor Input	Sensible To Total Ratio (S/T)			Total Cool Cap.	Comp. Motor Input	Sensible To Total Ratio (S/T)			Total Cool Cap.	Comp. Motor Input	Sensible To Total Ratio (S/T)			Total Cool Cap.	Comp. Motor Input	Sensible To Total Ratio (S/T)		
				Dry Bulb					Dry Bulb					Dry Bulb					Dry Bulb		
cfm	kBtuh	kW	75°F	80°F	85°F	kBtuh	kW	75°F	80°F	85°F	kBtuh	kW	75°F	80°F	85°F	kBtuh	kW	75°F	80°F	85°F	
63°F	1600	58.8	2.22	0.78	0.89	0.96	57	2.66	0.78	0.89	0.96	55.1	3.08	0.79	0.89	0.96	52.5	3.5	0.79	0.9	0.97
	2000	62.7	2.22	0.8	0.91	0.97	60.6	2.67	0.8	0.91	0.98	58.4	3.09	0.81	0.92	0.98	56	3.52	0.81	0.93	0.99
	2400	65.8	2.22	0.82	0.93	0.99	63.6	2.67	0.82	0.94	0.99	60.9	3.1	0.83	0.94	0.99	58.6	3.53	0.84	0.95	1
67°F	1600	62	2.22	0.51	0.72	0.85	60	2.67	0.51	0.72	0.85	57.8	3.09	0.51	0.73	0.86	55.3	3.51	0.51	0.74	0.87
	2000	65.8	2.22	0.52	0.75	0.88	63.8	2.67	0.52	0.75	0.88	61.4	3.1	0.52	0.76	0.89	58.7	3.53	0.52	0.78	0.9
	2400	68.9	2.23	0.54	0.78	0.9	66.6	2.68	0.54	0.79	0.91	63.8	3.1	0.54	0.8	0.92	60.9	3.53	0.55	0.81	0.93
71°F	1600	65.5	2.22	0.25	0.46	0.65	63.4	2.67	0.24	0.46	0.65	61.2	3.1	0.24	0.46	0.66	58.6	3.53	0.22	0.45	0.67
	2000	69.3	2.23	0.23	0.47	0.68	67.2	2.68	0.23	0.47	0.69	64.4	3.1	0.22	0.47	0.7	61.6	3.54	0.21	0.48	0.71
	2400	72.3	2.23	0.22	0.49	0.72	69.7	2.68	0.22	0.49	0.73	67.1	3.11	0.21	0.49	0.74	63.9	3.54	0.21	0.5	0.76

15 TON - HIGH EFFICIENCY LGT180H5M/V (2 COMPRESSORS - PART LOAD)

Entering Wet Bulb Temperature	Total Air Volume	Outdoor Air Temperature Entering Outdoor Coil																			
		85°F					95°F					105°F					115°F				
		Total Cool Cap.	Comp. Motor Input	Sensible To Total Ratio (S/T)			Total Cool Cap.	Comp. Motor Input	Sensible To Total Ratio (S/T)			Total Cool Cap.	Comp. Motor Input	Sensible To Total Ratio (S/T)			Total Cool Cap.	Comp. Motor Input	Sensible To Total Ratio (S/T)		
				Dry Bulb					Dry Bulb					Dry Bulb					Dry Bulb		
cfm	kBtuh	kW	75°F	80°F	85°F	kBtuh	kW	75°F	80°F	85°F	kBtuh	kW	75°F	80°F	85°F	kBtuh	kW	75°F	80°F	85°F	
63°F	3200	116.6	6.41	0.76	0.87	0.93	111.5	7.27	0.77	0.87	0.94	106	8.21	0.78	0.88	0.95	100.3	9.32	0.79	0.89	0.96
	4000	123.2	6.43	0.79	0.89	0.96	118	7.3	0.8	0.9	0.97	112.3	8.25	0.81	0.91	0.98	105.7	9.35	0.82	0.92	0.99
	4800	128.9	6.45	0.82	0.92	0.98	123.5	7.32	0.83	0.93	0.99	117.7	8.28	0.84	0.94	0.99	110.8	9.39	0.85	0.95	1
67°F	3200	123.1	6.43	0.54	0.72	0.84	117.2	7.29	0.54	0.73	0.85	111.5	8.25	0.55	0.74	0.85	104.8	9.35	0.55	0.75	0.86
	4000	129.2	6.45	0.56	0.75	0.87	123.1	7.32	0.56	0.76	0.88	116.6	8.28	0.57	0.79	0.88	109.7	9.37	0.58	0.8	0.9
	4800	133.8	6.46	0.58	0.79	0.89	127.2	7.34	0.6	0.81	0.9	120.6	8.3	0.61	0.83	0.92	113.4	9.4	0.61	0.84	0.93
71°F	3200	129.9	6.45	0.33	0.5	0.66	124.2	7.32	0.32	0.51	0.67	117.6	8.28	0.3	0.5	0.69	110.8	9.38	0.29	0.51	0.71
	4000	136.1	6.47	0.33	0.53	0.71	130	7.35	0.33	0.54	0.74	123.2	8.31	0.32	0.54	0.74	116.3	9.41	0.32	0.55	0.77
	4800	141.5	6.48	0.33	0.55	0.77	134.7	7.36	0.33	0.56	0.78	127.4	8.33	0.32	0.57	0.79	119.7	9.43	0.32	0.58	0.8

15 TON - HIGH EFFICIENCY LGT180H5M/V (3 COMPRESSORS - FULL LOAD)

Entering Wet Bulb Temperature	Total Air Volume	Outdoor Air Temperature Entering Outdoor Coil																			
		85°F					95°F					105°F					115°F				
		Total Cool Cap.	Comp. Motor Input	Sensible To Total Ratio (S/T)			Total Cool Cap.	Comp. Motor Input	Sensible To Total Ratio (S/T)			Total Cool Cap.	Comp. Motor Input	Sensible To Total Ratio (S/T)			Total Cool Cap.	Comp. Motor Input	Sensible To Total Ratio (S/T)		
				Dry Bulb					Dry Bulb					Dry Bulb					Dry Bulb		
cfm	kBtuh	kW	75°F	80°F	85°F	kBtuh	kW	75°F	80°F	85°F	kBtuh	kW	75°F	80°F	85°F	kBtuh	kW	75°F	80°F	85°F	
63°F	4800	176.8	9.96	0.71	0.82	0.91	168.5	11.28	0.71	0.83	0.93	160.3	12.76	0.74	0.85	0.95	151	14.48	0.74	0.86	0.96
	6000	187	9.98	0.75	0.87	0.97	178.6	11.32	0.76	0.88	0.98	170.3	12.84	0.78	0.89	0.99	160.2	14.53	0.79	0.91	1
	7200	196	10.01	0.79	0.91	1	186.7	11.35	0.8	0.92	1	177.3	12.85	0.81	0.94	1	166.4	14.56	0.83	0.97	1
67°F	4800	184.1	9.98	0.57	0.68	0.8	175.6	11.31	0.57	0.69	0.81	166.2	12.79	0.57	0.71	0.82	156.5	14.51	0.58	0.73	0.84
	6000	193	10.01	0.59	0.73	0.84	184	11.34	0.59	0.75	0.86	175.2	12.83	0.61	0.75	0.87	164.9	14.55	0.61	0.77	0.89
	7200	200.8	10.02	0.6	0.77	0.88	191.7	11.37	0.62	0.78	0.9	181.5	12.86	0.64	0.79	0.92	171	14.58	0.63	0.81	0.94
71°F	4800	193.8	10.02	0.43	0.54	0.66	184.6	11.35	0.42	0.55	0.67	175.1	12.85	0.42	0.57	0.68	167.2	14.56	0.43	0.57	0.7
	6000	203.9	10.04	0.43	0.57	0.7	194.1	11.38	0.42	0.59	0.72	183.6	12.87	0.44	0.6	0.74	172.9	14.6	0.45	0.6	0.75
	7200	211.2	10.06	0.45	0.61	0.75	200.5	11.4	0.46	0.61	0.76	190.1	12.9	0.45	0.62	0.78	178.4	14.64	0.44	0.62	0.8

RATINGS

NOTE – For Temperatures and Capacities not shown in tables, see bulletin – Cooling Unit Rating Table Correction Factor Data in Miscellaneous Engineering Data section.

17.5 TON - HIGH EFFICIENCY LGT210H5M/V (1 COMPRESSOR- PART LOAD)

Entering Wet Bulb Temperature	Total Air Volume	Outdoor Air Temperature Entering Outdoor Coil																			
		65°F					75°F					85°F					95°F				
		Total Cool Cap.	Comp. Motor Input	Sensible To Total Ratio (S/T)			Total Cool Cap.	Comp. Motor Input	Sensible To Total Ratio (S/T)			Total Cool Cap.	Comp. Motor Input	Sensible To Total Ratio (S/T)			Total Cool Cap.	Comp. Motor Input	Sensible To Total Ratio (S/T)		
				Dry Bulb					Dry Bulb					Dry Bulb					Dry Bulb		
cfm	kBtuh	kW	75°F	80°F	85°F	kBtuh	kW	75°F	80°F	85°F	kBtuh	kW	75°F	80°F	85°F	kBtuh	kW	75°F	80°F	85°F	
63°F	1600	55.3	2.07	0.65	0.79	0.9	52.1	2.36	0.65	0.79	0.91	48.9	2.69	0.63	0.79	0.92	45.5	3.07	0.62	0.8	0.93
	2000	59.2	2.08	0.68	0.83	0.95	55.8	2.36	0.67	0.83	0.96	52.3	2.69	0.67	0.84	0.97	48.9	3.08	0.67	0.85	0.98
	2400	62	2.08	0.71	0.87	0.98	58.7	2.37	0.71	0.88	0.99	55	2.7	0.71	0.89	1	51.1	3.08	0.71	0.9	1
67°F	1600	58.7	2.08	0.43	0.61	0.75	55.5	2.36	0.41	0.61	0.75	52.1	2.69	0.39	0.6	0.75	48.6	3.07	0.37	0.59	0.76
	2000	62.5	2.08	0.44	0.65	0.79	59.2	2.37	0.43	0.64	0.8	55.5	2.7	0.41	0.64	0.81	51.6	3.08	0.39	0.64	0.81
	2400	65.3	2.08	0.46	0.67	0.83	61.8	2.38	0.45	0.67	0.84	58.1	2.71	0.44	0.68	0.86	54.3	3.1	0.42	0.68	0.87
71°F	1600	62.9	2.08	0.21	0.39	0.57	59.7	2.37	0.18	0.38	0.56	56.2	2.7	0.15	0.36	0.55	52.8	3.09	0.12	0.34	0.55
	2000	66.5	2.09	0.2	0.41	0.61	63.1	2.38	0.17	0.4	0.6	59.5	2.71	0.14	0.38	0.6	55.7	3.1	0.11	0.37	0.6
	2400	69.4	2.09	0.19	0.43	0.64	65.8	2.39	0.17	0.42	0.64	62	2.72	0.15	0.41	0.64	57.6	3.11	0.12	0.4	0.64

17.5 TON - HIGH EFFICIENCY LGT210H5M/V (2 COMPRESSORS - PART LOAD)

Entering Wet Bulb Temperature	Total Air Volume	Outdoor Air Temperature Entering Outdoor Coil																			
		65°F					75°F					85°F					95°F				
		Total Cool Cap.	Comp. Motor Input	Sensible To Total Ratio (S/T)			Total Cool Cap.	Comp. Motor Input	Sensible To Total Ratio (S/T)			Total Cool Cap.	Comp. Motor Input	Sensible To Total Ratio (S/T)			Total Cool Cap.	Comp. Motor Input	Sensible To Total Ratio (S/T)		
				Dry Bulb					Dry Bulb					Dry Bulb					Dry Bulb		
cfm	kBtuh	kW	75°F	80°F	85°F	kBtuh	kW	75°F	80°F	85°F	kBtuh	kW	75°F	80°F	85°F	kBtuh	kW	75°F	80°F	85°F	
63°F	2800	110.5	4.22	0.72	0.83	0.92	104	4.8	0.72	0.83	0.93	97.6	5.47	0.71	0.84	0.94	90.8	6.24	0.71	0.84	0.95
	3500	118.8	4.24	0.75	0.87	0.97	112	4.82	0.75	0.88	0.98	104.9	5.49	0.75	0.89	0.99	98	6.27	0.76	0.9	0.99
	4200	125.4	4.25	0.78	0.91	1	118.2	4.84	0.79	0.92	1	110.9	5.52	0.79	0.94	1	103.5	6.3	0.8	0.95	1
67°F	2800	117	4.23	0.59	0.7	0.8	110	4.81	0.57	0.7	0.81	104.1	5.49	0.56	0.69	0.81	96.2	6.26	0.55	0.7	0.82
	3500	125.2	4.25	0.61	0.74	0.85	118	4.84	0.6	0.74	0.85	110.9	5.52	0.59	0.74	0.86	103.1	6.29	0.58	0.74	0.87
	4200	131.6	4.26	0.63	0.77	0.89	124.1	4.86	0.63	0.77	0.9	116.4	5.54	0.62	0.78	0.91	108.3	6.32	0.61	0.78	0.93
71°F	2800	125	4.25	0.46	0.57	0.68	118.4	4.84	0.44	0.57	0.68	111.2	5.51	0.42	0.55	0.68	103.8	6.29	0.39	0.54	0.68
	3500	133.9	4.27	0.47	0.6	0.72	126.5	4.87	0.45	0.59	0.72	118.9	5.55	0.43	0.58	0.72	111	6.34	0.41	0.58	0.73
	4200	140.6	4.29	0.48	0.62	0.76	132.6	4.89	0.47	0.62	0.76	122.4	5.57	0.45	0.62	0.77	116.3	6.37	0.43	0.61	0.77

17.5 TON - HIGH EFFICIENCY LGT210H5M/V (3 COMPRESSORS - PART LOAD)

Entering Wet Bulb Temperature	Total Air Volume	Outdoor Air Temperature Entering Outdoor Coil																			
		85°F					95°F					105°F					115°F				
		Total Cool Cap.	Comp. Motor Input	Sensible To Total Ratio (S/T)			Total Cool Cap.	Comp. Motor Input	Sensible To Total Ratio (S/T)			Total Cool Cap.	Comp. Motor Input	Sensible To Total Ratio (S/T)			Total Cool Cap.	Comp. Motor Input	Sensible To Total Ratio (S/T)		
				Dry Bulb					Dry Bulb					Dry Bulb					Dry Bulb		
cfm	kBtuh	kW	75°F	80°F	85°F	kBtuh	kW	75°F	80°F	85°F	kBtuh	kW	75°F	80°F	85°F	kBtuh	kW	75°F	80°F	85°F	
63°F	4200	151.2	8.22	0.76	0.92	0.99	140.3	9.38	0.75	0.93	0.99	128.6	10.71	0.73	0.94	0.99	116.6	12.21	0.72	0.95	0.99
	5250	160.7	8.27	0.82	0.97	1	149.8	9.44	0.82	0.97	1	138.5	10.77	0.84	0.97	1	126.4	12.27	0.84	0.97	1
	6300	169.7	8.31	0.87	0.98	1	158.4	9.49	0.88	0.98	1	146.4	10.82	0.9	0.99	1	133.9	12.33	0.9	0.99	1
67°F	4200	162.6	8.26	0.5	0.71	0.89	151.2	9.42	0.47	0.7	0.9	139	10.75	0.43	0.69	0.91	126.6	12.25	0.38	0.69	0.93
	5250	171.8	8.31	0.51	0.78	0.94	159.9	9.48	0.48	0.8	0.96	147.6	10.81	0.46	0.8	0.95	134.4	12.32	0.43	0.81	0.96
	6300	178.9	8.36	0.55	0.85	0.97	166.6	9.53	0.55	0.85	0.97	153.4	10.86	0.53	0.87	0.98	139.8	12.38	0.5	0.88	0.98
71°F	4200	173.9	8.32	0.26	0.46	0.67	162.6	9.49	0.22	0.43	0.67	150.3	10.82	0.19	0.4	0.64	137	12.32	0.13	0.38	0.63
	5250	183.6	8.37	0.27	0.49	0.73	171.4	9.55	0.24	0.46	0.73	158.5	10.89	0.18	0.44	0.75	145.1	12.41	0.14	0.41	0.77
	6300	190.7	8.42	0.28	0.53	0.82	177.9	9.61	0.24	0.51	0.83	164.6	10.94	0.21	0.49	0.83	150.1	12.44	0.15	0.48	0.86

17.5 TON - HIGH EFFICIENCY LGT210H5M/V (4 COMPRESSORS - FULL LOAD)

Entering Wet Bulb Temperature	Total Air Volume	Outdoor Air Temperature Entering Outdoor Coil																			
		85°F					95°F					105°F					115°F				
		Total Cool Cap.	Comp. Motor Input	Sensible To Total Ratio (S/T)			Total Cool Cap.	Comp. Motor Input	Sensible To Total Ratio (S/T)			Total Cool Cap.	Comp. Motor Input	Sensible To Total Ratio (S/T)			Total Cool Cap.	Comp. Motor Input	Sensible To Total Ratio (S/T)		
				Dry Bulb					Dry Bulb					Dry Bulb					Dry Bulb		
cfm	kBtuh	kW	75°F	80°F	85°F	kBtuh	kW	75°F	80°F	85°F	kBtuh	kW	75°F	80°F	85°F	kBtuh	kW	75°F	80°F	85°F	
63°F	5600	208.1	11.29	0.67	0.83	0.91	193.8	12.87	0.67	0.83	0.92	178.7	14.77	0.67	0.83	0.93	162.5	16.85	0.67	0.84	0.95
	7000	223.8	11.34	0.73	0.87	0.96	208.6	12.94	0.73	0.87	0.97	193.2	14.85	0.74	0.88	0.99	176.7	16.96	0.76	0.9	0.99
	8400	236.1	11.4	0.79	0.91	0.99	220.4	13.02	0.79	0.92	1	204.3	14.86	0.8	0.93	1	186.7	17.01	0.81	0.95	1
67°F	5600	222.9	11.34	0.51	0.65	0.8	207.4	12.92	0.49	0.65	0.81	191.4	14.83	0.48	0.65	0.81	173.8	16.92	0.45	0.67	0.82
	7000	236.3	11.4	0.53	0.71	0.85	219.8	13	0.52	0.72	0.86	203	14.9	0.51	0.73	0.86	184.9	17.01	0.51	0.75	0.88
	8400	245.5	11.45	0.57	0.78	0.89	228.5	13.06	0.56	0.78	0.9	211.1	14.91	0.56	0.8	0.91	192.5	17.04	0.56	0.82	0.93
71°F	5600	239	11.4	0.36	0.49	0.63	222.7	13.01	0.34	0.49	0.63	206.4	14.92	0.31	0.46	0.63	188.9	17.02	0.28	0.45	0.63
	7000	251.8	11.48	0.37	0.53	0.69	235.2	13.1	0.35	0.52	0.69	217.7	14.99	0.34	0.51	0.71	198.7	17.11	0.28	0.51	0.72
	8400	261.7	11.54	0.38	0.56	0.75	244.2	13.17	0.37	0.55	0.77	225.2	15.05	0.36	0.56	0.77	207.2	17.17	0.32	0.55	0.79

RATINGS

NOTE – For Temperatures and Capacities not shown in tables, see bulletin – Cooling Unit Rating Table Correction Factor Data in Miscellaneous Engineering Data section.

20 TON - HIGH EFFICIENCY LGT240H5M/V (1 COMPRESSOR- PART LOAD)

Entering Wet Bulb Temperature	Total Air Volume	Outdoor Air Temperature Entering Outdoor Coil																			
		65°F					75°F					85°F					95°F				
		Total Cool Cap.	Comp. Motor Input	Sensible To Total Ratio (S/T)			Total Cool Cap.	Comp. Motor Input	Sensible To Total Ratio (S/T)			Total Cool Cap.	Comp. Motor Input	Sensible To Total Ratio (S/T)			Total Cool Cap.	Comp. Motor Input	Sensible To Total Ratio (S/T)		
				Dry Bulb					Dry Bulb					Dry Bulb					Dry Bulb		
cfm	kBtuh	kW	75°F	80°F	85°F	kBtuh	kW	75°F	80°F	85°F	kBtuh	kW	75°F	80°F	85°F	kBtuh	kW	75°F	80°F	85°F	
63°F	1600	58.9	2.37	0.58	0.71	0.84	57.1	2.8	0.58	0.72	0.85	55.4	3.23	0.59	0.73	0.86	53.3	3.68	0.59	0.74	0.88
	2000	62.6	2.38	0.6	0.75	0.88	60.7	2.81	0.61	0.76	0.9	58.5	3.24	0.61	0.77	0.92	56.3	3.69	0.62	0.78	0.93
	2400	65.6	2.38	0.62	0.79	0.93	63.7	2.82	0.63	0.8	0.95	61.4	3.25	0.63	0.81	0.97	58.9	3.7	0.65	0.83	0.98
67°F	1600	61.8	2.38	0.38	0.54	0.66	59.9	2.81	0.38	0.54	0.67	58.2	3.23	0.38	0.54	0.67	55.8	3.69	0.39	0.55	0.69
	2000	65.7	2.38	0.39	0.56	0.7	63.7	2.82	0.39	0.56	0.71	60.9	3.24	0.39	0.57	0.72	58.8	3.69	0.39	0.58	0.74
	2400	68.6	2.39	0.4	0.58	0.74	66.5	2.82	0.4	0.59	0.75	64	3.25	0.41	0.6	0.77	61.1	3.7	0.41	0.61	0.79
71°F	1600	65.2	2.38	0.18	0.34	0.49	63.3	2.82	0.18	0.34	0.49	61.2	3.24	0.18	0.34	0.5	58.9	3.69	0.17	0.34	0.5
	2000	68.9	2.39	0.17	0.35	0.51	67	2.83	0.16	0.35	0.52	64.3	3.25	0.16	0.35	0.53	61.7	3.7	0.16	0.36	0.53
	2400	71.9	2.4	0.16	0.36	0.53	69.4	2.83	0.16	0.36	0.55	66.8	3.26	0.16	0.37	0.56	64.3	3.71	0.16	0.38	0.57

20 TON - HIGH EFFICIENCY LGT240H5M/V (2 COMPRESSORS - PART LOAD)

Entering Wet Bulb Temperature	Total Air Volume	Outdoor Air Temperature Entering Outdoor Coil																			
		65°F					75°F					85°F					95°F				
		Total Cool Cap.	Comp. Motor Input	Sensible To Total Ratio (S/T)			Total Cool Cap.	Comp. Motor Input	Sensible To Total Ratio (S/T)			Total Cool Cap.	Comp. Motor Input	Sensible To Total Ratio (S/T)			Total Cool Cap.	Comp. Motor Input	Sensible To Total Ratio (S/T)		
				Dry Bulb					Dry Bulb					Dry Bulb					Dry Bulb		
cfm	kBtuh	kW	75°F	80°F	85°F	kBtuh	kW	75°F	80°F	85°F	kBtuh	kW	75°F	80°F	85°F	kBtuh	kW	75°F	80°F	85°F	
63°F	3200	123.7	5.24	0.71	0.82	0.92	119.3	6.07	0.71	0.83	0.93	114.9	6.92	0.72	0.84	0.94	110.2	7.82	0.73	0.85	0.96
	4000	131.4	5.27	0.74	0.86	0.97	126.8	6.1	0.75	0.87	0.98	121.8	6.95	0.76	0.89	0.99	116.4	7.85	0.77	0.9	1
	4800	137.1	5.28	0.77	0.91	1	132.2	6.12	0.78	0.92	1	127	6.97	0.79	0.94	1	121.9	7.87	0.81	0.95	1
67°F	3200	129.1	5.26	0.57	0.68	0.79	126	6.1	0.57	0.69	0.8	119.9	6.94	0.57	0.7	0.81	114.6	7.84	0.58	0.71	0.82
	4000	136.2	5.28	0.59	0.72	0.84	131.6	6.12	0.6	0.73	0.85	126.2	6.96	0.59	0.74	0.86	120.9	7.86	0.6	0.75	0.88
	4800	142.3	5.3	0.62	0.75	0.88	137.5	6.14	0.61	0.76	0.89	132.1	6.99	0.62	0.77	0.91	125.6	7.88	0.62	0.79	0.93
71°F	3200	136.7	5.28	0.44	0.55	0.66	131.8	6.12	0.43	0.56	0.67	126.8	6.97	0.43	0.56	0.68	121.6	7.87	0.43	0.56	0.69
	4000	144.7	5.3	0.44	0.57	0.7	139.8	6.15	0.44	0.58	0.71	133.4	6.99	0.44	0.58	0.72	126.3	7.88	0.43	0.6	0.73
	4800	150.7	5.32	0.45	0.6	0.73	145.1	6.16	0.45	0.6	0.75	138.9	7.01	0.45	0.61	0.76	131.2	7.9	0.45	0.63	0.77

20 TON - HIGH EFFICIENCY LGT240H5M/V (3 COMPRESSORS - PART LOAD)

Entering Wet Bulb Temperature	Total Air Volume	Outdoor Air Temperature Entering Outdoor Coil																			
		85°F					95°F					105°F					115°F				
		Total Cool Cap.	Comp. Motor Input	Sensible To Total Ratio (S/T)			Total Cool Cap.	Comp. Motor Input	Sensible To Total Ratio (S/T)			Total Cool Cap.	Comp. Motor Input	Sensible To Total Ratio (S/T)			Total Cool Cap.	Comp. Motor Input	Sensible To Total Ratio (S/T)		
				Dry Bulb					Dry Bulb					Dry Bulb					Dry Bulb		
cfm	kBtuh	kW	75°F	80°F	85°F	kBtuh	kW	75°F	80°F	85°F	kBtuh	kW	75°F	80°F	85°F	kBtuh	kW	75°F	80°F	85°F	
63°F	4800	176.7	10.4	0.76	0.9	0.96	169.6	11.77	0.77	0.91	0.97	160.9	13.28	0.79	0.93	0.97	152.7	14.99	0.8	0.94	0.98
	6000	186.8	10.44	0.81	0.94	0.98	179	11.81	0.82	0.94	0.99	170.5	13.31	0.83	0.95	0.99	161.7	15.02	0.86	0.96	1
	7200	194.3	10.47	0.86	0.95	0.99	186.2	11.84	0.87	0.96	1	177.7	13.34	0.88	0.97	1	169	15.04	0.91	0.98	1
67°F	4800	185.2	10.44	0.54	0.71	0.87	177.2	11.8	0.54	0.72	0.88	168.5	13.32	0.55	0.75	0.9	159.3	15.02	0.55	0.75	0.92
	6000	193.8	10.47	0.57	0.77	0.92	185.3	11.84	0.55	0.79	0.93	176.7	13.34	0.56	0.8	0.93	167	15.05	0.57	0.82	0.94
	7200	201	10.5	0.57	0.83	0.94	192.1	11.87	0.58	0.84	0.95	182.5	13.36	0.59	0.86	0.96	172.7	15.06	0.6	0.89	0.97
71°F	4800	196.8	10.48	0.3	0.51	0.65	186.3	11.85	0.3	0.47	0.66	179	13.35	0.3	0.52	0.69	169.4	15.06	0.29	0.53	0.71
	6000	204.5	10.51	0.32	0.5	0.72	196.7	11.88	0.33	0.55	0.74	185	13.38	0.32	0.53	0.76	174.8	15.07	0.26	0.53	0.8
	7200	210.9	10.54	0.34	0.55	0.79	201.3	11.9	0.32	0.56	0.82	191.1	13.39	0.32	0.57	0.84	180.3	15.09	0.35	0.59	0.86

20 TON - HIGH EFFICIENCY LGT240H5M/V (4 COMPRESSORS - FULL LOAD)

Entering Wet Bulb Temperature	Total Air Volume	Outdoor Air Temperature Entering Outdoor Coil																			
		85°F					95°F					105°F					115°F				
		Total Cool Cap.	Comp. Motor Input	Sensible To Total Ratio (S/T)			Total Cool Cap.	Comp. Motor Input	Sensible To Total Ratio (S/T)			Total Cool Cap.	Comp. Motor Input	Sensible To Total Ratio (S/T)			Total Cool Cap.	Comp. Motor Input	Sensible To Total Ratio (S/T)		
				Dry Bulb					Dry Bulb					Dry Bulb					Dry Bulb		
cfm	kBtuh	kW	75°F	80°F	85°F	kBtuh	kW	75°F	80°F	85°F	kBtuh	kW	75°F	80°F	85°F	kBtuh	kW	75°F	80°F	85°F	
63°F	6400	232.2	13.86	0.7	0.85	0.93	222.2	15.66	0.71	0.85	0.94	211.7	17.66	0.74	0.87	0.96	200.9	19.93	0.75	0.88	0.98
	8000	245.1	13.92	0.76	0.89	0.98	234.8	15.72	0.77	0.9	0.99	223.8	17.71	0.8	0.92	1	212.2	19.97	0.81	0.93	1
	9600	255.9	13.96	0.82	0.93	1	244.8	15.76	0.82	0.94	1	232.8	17.75	0.84	0.96	1	220.1	20	0.86	0.98	1
67°F	6400	242.8	13.91	0.54	0.68	0.82	232.4	15.71	0.55	0.7	0.83	220.5	17.7	0.56	0.71	0.84	208.6	19.97	0.56	0.73	0.86
	8000	254.5	13.96	0.57	0.74	0.87	242.7	15.76	0.58	0.75	0.88	230.6	17.75	0.59	0.78	0.89	217.3	20	0.6	0.79	0.91
	9600	262.7	14	0.6	0.79	0.91	250.7	15.79	0.62	0.81	0.92	238	17.78	0.62	0.83	0.94	224.5	20.03	0.63	0.86	0.96
71°F	6400	255.1	13.96	0.4	0.53	0.65	243.8	15.76	0.38	0.53	0.66	232.1	17.75	0.4	0.54	0.69	219	20.01	0.39	0.55	0.71
	8000	266.7	14.01	0.41	0.55	0.71	254.4	15.81	0.42	0.56	0.73	241.5	17.79	0.4	0.57	0.75	228.6	20.04	0.4	0.58	0.78
	9600	275	14.04	0.42	0.6	0.77	262.2	15.84	0.41	0.6	0.79	249.3	17.82	0.4	0.61	0.81	235.2	20.07	0.41	0.64	0.83

RATINGS

NOTE – For Temperatures and Capacities not shown in tables, see bulletin – Cooling Unit Rating Table Correction Factor Data in Miscellaneous Engineering Data section.

25 TON - HIGH EFFICIENCY LGT300H5M/V (1 COMPRESSOR- PART LOAD)

Entering Wet Bulb Temperature	Total Air Volume	Outdoor Air Temperature Entering Outdoor Coil																			
		65°F					75°F					85°F					95°F				
		Total Cool Cap.	Comp. Motor Input	Sensible To Total Ratio (S/T)			Total Cool Cap.	Comp. Motor Input	Sensible To Total Ratio (S/T)			Total Cool Cap.	Comp. Motor Input	Sensible To Total Ratio (S/T)			Total Cool Cap.	Comp. Motor Input	Sensible To Total Ratio (S/T)		
				Dry Bulb					Dry Bulb					Dry Bulb					Dry Bulb		
cfm	kBtuh	kW	75°F	80°F	85°F	kBtuh	kW	75°F	80°F	85°F	kBtuh	kW	75°F	80°F	85°F	kBtuh	kW	75°F	80°F	85°F	
63°F	2000	69.1	3.19	0.59	0.73	0.86	66.9	3.64	0.59	0.74	0.87	64.1	4.14	0.6	0.75	0.89	61.5	4.72	0.61	0.77	0.91
	2500	72.7	3.22	0.62	0.78	0.91	70.2	3.68	0.62	0.79	0.93	67.7	4.19	0.63	0.8	0.95	64.8	4.76	0.65	0.82	0.97
	3000	76	3.25	0.65	0.81	0.96	73.3	3.71	0.66	0.83	0.98	70.4	4.22	0.67	0.85	0.99	67.1	4.79	0.68	0.87	1
67°F	2000	72.4	3.22	0.39	0.54	0.69	69.6	3.67	0.39	0.55	0.69	67.1	4.18	0.39	0.56	0.71	64.4	4.75	0.39	0.57	0.72
	2500	76.2	3.25	0.4	0.57	0.73	73.6	3.71	0.4	0.59	0.74	70.8	4.22	0.41	0.6	0.76	67.9	4.8	0.41	0.61	0.77
	3000	79.3	3.29	0.42	0.61	0.77	76.3	3.74	0.42	0.62	0.79	73.7	4.26	0.43	0.63	0.81	70.3	4.83	0.44	0.65	0.83
71°F	2000	75.4	3.24	0.18	0.35	0.49	73.1	3.71	0.18	0.35	0.5	70.4	4.22	0.17	0.35	0.51	67.6	4.79	0.17	0.35	0.52
	2500	79.6	3.29	0.17	0.36	0.53	76.7	3.75	0.17	0.37	0.54	74.1	4.26	0.17	0.37	0.55	70.9	4.84	0.17	0.38	0.57
	3000	82.8	3.32	0.17	0.38	0.57	79.5	3.78	0.17	0.39	0.58	76.7	4.3	0.16	0.4	0.59	73.4	4.87	0.16	0.4	0.61

25 TON - HIGH EFFICIENCY LGT300H5M/V (2 COMPRESSORS - PART LOAD)

Entering Wet Bulb Temperature	Total Air Volume	Outdoor Air Temperature Entering Outdoor Coil																			
		65°F					75°F					85°F					95°F				
		Total Cool Cap.	Comp. Motor Input	Sensible To Total Ratio (S/T)			Total Cool Cap.	Comp. Motor Input	Sensible To Total Ratio (S/T)			Total Cool Cap.	Comp. Motor Input	Sensible To Total Ratio (S/T)			Total Cool Cap.	Comp. Motor Input	Sensible To Total Ratio (S/T)		
				Dry Bulb					Dry Bulb					Dry Bulb					Dry Bulb		
cfm	kBtuh	kW	75°F	80°F	85°F	kBtuh	kW	75°F	80°F	85°F	kBtuh	kW	75°F	80°F	85°F	kBtuh	kW	75°F	80°F	85°F	
63°F	4000	142.7	7.01	0.71	0.84	0.94	137.4	7.94	0.72	0.85	0.95	132.1	9	0.73	0.86	0.97	126.7	10.19	0.74	0.87	0.98
	5000	151.2	7.1	0.75	0.89	0.99	145.9	8.05	0.76	0.9	1	139.6	9.1	0.77	0.92	1	133.4	10.28	0.79	0.93	1
	6000	157.2	7.17	0.79	0.93	1	151.5	8.12	0.8	0.95	1	145.2	9.18	0.81	0.97	1	138.7	10.37	0.83	0.98	1
67°F	4000	151.3	7.1	0.57	0.69	0.81	146	8.05	0.57	0.7	0.82	139.8	9.1	0.58	0.71	0.83	133.4	10.28	0.58	0.72	0.85
	5000	158.9	7.18	0.6	0.73	0.86	153	8.14	0.61	0.74	0.87	147	9.21	0.61	0.75	0.89	140.2	10.38	0.62	0.77	0.91
	6000	165.4	7.27	0.62	0.77	0.91	157.4	8.2	0.63	0.78	0.93	151.5	9.27	0.64	0.8	0.94	144.1	10.44	0.64	0.81	0.96
71°F	4000	158.1	7.17	0.43	0.56	0.67	152.4	8.13	0.43	0.56	0.68	146.4	9.19	0.42	0.56	0.69	140.5	10.39	0.42	0.57	0.7
	5000	166.9	7.29	0.43	0.59	0.71	160.5	8.24	0.43	0.59	0.72	154.2	9.31	0.43	0.6	0.73	146.8	10.5	0.43	0.61	0.75
	6000	173.8	7.37	0.44	0.61	0.75	166.3	8.32	0.44	0.62	0.76	159.4	9.39	0.45	0.63	0.78	151.6	10.57	0.45	0.64	0.8

25 TON - HIGH EFFICIENCY LGT300H5M/V (3 COMPRESSORS - PART LOAD)

Entering Wet Bulb Temperature	Total Air Volume	Outdoor Air Temperature Entering Outdoor Coil																			
		85°F					95°F					105°F					115°F				
		Total Cool Cap.	Comp. Motor Input	Sensible To Total Ratio (S/T)			Total Cool Cap.	Comp. Motor Input	Sensible To Total Ratio (S/T)			Total Cool Cap.	Comp. Motor Input	Sensible To Total Ratio (S/T)			Total Cool Cap.	Comp. Motor Input	Sensible To Total Ratio (S/T)		
				Dry Bulb					Dry Bulb					Dry Bulb					Dry Bulb		
cfm	kBtuh	kW	75°F	80°F	85°F	kBtuh	kW	75°F	80°F	85°F	kBtuh	kW	75°F	80°F	85°F	kBtuh	kW	75°F	80°F	85°F	
63°F	6000	205.4	13.47	0.71	0.87	0.94	196.9	15.24	0.72	0.88	0.95	187.5	17.24	0.73	0.9	0.96	177.3	19.5	0.75	0.9	0.97
	7500	216.3	13.61	0.76	0.91	0.97	207.5	15.4	0.78	0.92	0.98	198.2	17.41	0.79	0.93	0.99	187.4	19.68	0.83	0.94	1
	9000	225.3	13.73	0.82	0.93	0.99	216.1	15.52	0.83	0.94	1	206	17.53	0.86	0.95	1	194.4	19.79	0.87	0.96	1
67°F	6000	216.5	13.61	0.5	0.67	0.83	206.1	15.38	0.51	0.68	0.84	195.7	17.37	0.51	0.69	0.86	184.4	19.63	0.53	0.72	0.89
	7500	225.5	13.73	0.53	0.72	0.88	214.8	15.51	0.54	0.74	0.9	204.1	17.51	0.55	0.77	0.91	193	19.78	0.56	0.79	0.92
	9000	232.2	13.82	0.57	0.78	0.92	222.1	15.62	0.57	0.8	0.93	210.3	17.61	0.59	0.84	0.94	198.8	19.89	0.6	0.86	0.95
71°F	6000	228.7	13.77	0.3	0.48	0.63	218.5	15.56	0.31	0.48	0.62	207.5	17.56	0.3	0.48	0.65	196.6	19.85	0.3	0.5	0.68
	7500	238.8	13.91	0.31	0.5	0.68	227.5	15.7	0.31	0.51	0.7	216.2	17.71	0.32	0.52	0.73	203.5	19.98	0.3	0.55	0.76
	9000	245.9	14	0.31	0.55	0.76	234.3	15.8	0.32	0.56	0.78	221.7	17.8	0.32	0.58	0.8	209.3	20.07	0.33	0.59	0.84

25 TON - HIGH EFFICIENCY LGT300H5M/V (4 COMPRESSORS - FULL LOAD)

Entering Wet Bulb Temperature	Total Air Volume	Outdoor Air Temperature Entering Outdoor Coil																			
		85°F					95°F					105°F					115°F				
		Total Cool Cap.	Comp. Motor Input	Sensible To Total Ratio (S/T)			Total Cool Cap.	Comp. Motor Input	Sensible To Total Ratio (S/T)			Total Cool Cap.	Comp. Motor Input	Sensible To Total Ratio (S/T)			Total Cool Cap.	Comp. Motor Input	Sensible To Total Ratio (S/T)		
				Dry Bulb					Dry Bulb					Dry Bulb					Dry Bulb		
cfm	kBtuh	kW	75°F	80°F	85°F	kBtuh	kW	75°F	80°F	85°F	kBtuh	kW	75°F	80°F	85°F	kBtuh	kW	75°F	80°F	85°F	
63°F	8000	279.5	18.44	0.71	0.84	0.93	267.9	20.84	0.72	0.86	0.95	254.9	23.52	0.75	0.87	0.97	242	26.59	0.76	0.89	0.98
	9500	290.4	18.56	0.74	0.88	0.98	278.1	20.98	0.77	0.89	0.99	265.2	23.67	0.8	0.91	1	252.1	26.75	0.81	0.93	1
	11000	300.4	18.68	0.78	0.91	1	287.2	21.1	0.81	0.93	1	274.4	23.82	0.82	0.95	1	259	26.88	0.84	0.97	1
67°F	8000	290	18.54	0.55	0.68	0.82	278.2	20.96	0.55	0.7	0.83	264.9	23.67	0.56	0.71	0.85	252.2	26.77	0.57	0.74	0.86
	9500	300.1	18.66	0.57	0.72	0.86	289.9	21.13	0.57	0.75	0.87	275.5	23.84	0.6	0.76	0.89	259.6	26.9	0.6	0.79	0.91
	11000	311.7	18.79	0.59	0.77	0.89	297.4	21.23	0.61	0.79	0.91	281.7	23.94	0.62	0.82	0.93	266.3	27.01	0.64	0.82	0.95
71°F	8000	306.7	18.74	0.4	0.53	0.65	293.9	21.17	0.41	0.54	0.67	279.7	23.88	0.41	0.55	0.69	263.7	26.94	0.41	0.55	0.71
	9500	317.6	18.86	0.42	0.56	0.7	302.1	21.28	0.42	0.56	0.71	288.2	24.02	0.42	0.57	0.74	272.2	27.1	0.41	0.6	0.76
	11000	324.9	18.94	0.42	0.59	0.75	311.3	21.4	0.43	0.6	0.77	295.2	24.13	0.43	0.61	0.79	278.7	27.2	0.45	0.63	0.81

HUMIDITROL® DEHUMIDIFICATION SYSTEM RATINGS

13 TON - HIGH EFFICIENCY LGT156H5 WITH HUMIDITROL® OPERATING (COMPRESSOR 1 AND 2 IN REHEAT)

Entering Wet Bulb Temperature	Total Air Volume	Outdoor Air Temperature Entering Outdoor Coil																			
		65°F					75°F					85°F					95°F				
		Total Cool Cap.	Comp. Motor Input	Sensible To Total Ratio (S/T)			Total Cool Cap.	Comp. Motor Input	Sensible To Total Ratio (S/T)			Total Cool Cap.	Comp. Motor Input	Sensible To Total Ratio (S/T)			Total Cool Cap.	Comp. Motor Input	Sensible To Total Ratio (S/T)		
				Dry Bulb					Dry Bulb					Dry Bulb					Dry Bulb		
cfm	kBtuh	kW	75°F	80°F	85°F	kBtuh	kW	75°F	80°F	85°F	kBtuh	kW	75°F	80°F	85°F	kBtuh	kW	75°F	80°F	85°F	
63°F	2080	86.9	6.20	0.43	0.54	0.67	74.0	7.06	0.35	0.49	0.63	61.2	8.01	0.25	0.42	0.59	48.5	9.08	0.08	0.30	0.51
	2600	94.9	6.21	0.50	0.63	0.75	80.8	7.08	0.42	0.59	0.72	66.3	8.03	0.35	0.54	0.69	52.1	9.11	0.21	0.44	0.64
	3120	101.5	6.22	0.53	0.68	0.79	86.3	7.10	0.48	0.65	0.77	69.9	8.06	0.39	0.60	0.75	53.8	9.14	0.23	0.55	0.71
67°F	2080	97.7	6.21	0.30	0.40	0.52	84.8	7.08	0.21	0.40	0.47	72.0	8.03	0.17	0.31	0.45	59.0	9.11	0.01	0.19	0.39
	2600	107.2	6.23	0.36	0.49	0.60	92.4	7.10	0.29	0.43	0.58	77.3	8.06	0.19	0.36	0.52	61.3	9.13	0.04	0.25	0.46
	3120	113.1	6.23	0.39	0.52	0.65	96.5	7.11	0.31	0.48	0.61	80.3	8.08	0.21	0.39	0.59	63.0	9.15	0.06	0.28	0.53
71°F	2080	109.0	6.23	0.24	0.35	0.44	96.1	7.10	0.16	0.27	0.39	82.8	8.06	0.06	0.20	0.32	69.1	9.13	-0.10	0.08	0.23
	2600	118.3	6.24	0.25	0.36	0.47	103.0	7.13	0.16	0.29	0.42	87.7	8.09	0.04	0.21	0.35	71.8	9.16	-0.10	0.09	0.26
	3120	125.2	6.25	0.27	0.38	0.50	108.4	7.13	0.18	0.34	0.46	91.5	8.10	0.06	0.24	0.41	74.7	9.18	-0.09	0.12	0.33

13 TON - HIGH EFFICIENCY LGT156H5 WITH HUMIDITROL® (COMPRESSOR 1 IN REHEAT, COMPRESSOR 2 ON)

Entering Wet Bulb Temperature	Total Air Volume	Outdoor Air Temperature Entering Outdoor Coil																			
		65°F					75°F					85°F					95°F				
		Total Cool Cap.	Comp. Motor Input	Sensible To Total Ratio (S/T)			Total Cool Cap.	Comp. Motor Input	Sensible To Total Ratio (S/T)			Total Cool Cap.	Comp. Motor Input	Sensible To Total Ratio (S/T)			Total Cool Cap.	Comp. Motor Input	Sensible To Total Ratio (S/T)		
				Dry Bulb					Dry Bulb					Dry Bulb					Dry Bulb		
cfm	kBtuh	kW	75°F	80°F	85°F	kBtuh	kW	75°F	80°F	85°F	kBtuh	kW	75°F	80°F	85°F	kBtuh	kW	75°F	80°F	85°F	
63°F	4160	126.8	7.54	0.68	0.81	0.90	115.2	8.51	0.68	0.82	0.91	103.8	9.57	0.66	0.82	0.92	92.0	10.74	0.65	0.82	0.93
	5200	133.4	7.66	0.73	0.86	0.95	120.7	8.64	0.71	0.87	0.97	108.4	9.71	0.71	0.88	0.98	95.6	10.89	0.70	0.89	0.99
	6240	138.3	7.75	0.76	0.91	0.99	124.7	8.73	0.76	0.92	0.99	111.4	9.81	0.76	0.94	0.99	97.5	10.98	0.75	0.96	0.99
67°F	4160	132.1	7.60	0.51	0.66	0.78	120.4	8.58	0.49	0.65	0.78	108.2	9.64	0.47	0.65	0.78	96.2	10.80	0.42	0.65	0.78
	5200	137.9	7.70	0.54	0.72	0.82	125.2	8.69	0.51	0.72	0.83	112.4	9.76	0.49	0.72	0.84	99.9	10.96	0.46	0.72	0.85
	6240	142.7	7.79	0.56	0.77	0.87	129.3	8.79	0.56	0.77	0.88	116.0	9.89	0.53	0.77	0.89	101.8	11.06	0.52	0.77	0.91
71°F	4160	141.4	7.72	0.35	0.50	0.65	129.4	8.71	0.32	0.49	0.64	117.0	9.78	0.27	0.46	0.64	104.6	10.96	0.23	0.45	0.62
	5200	146.7	7.81	0.36	0.52	0.69	133.5	8.81	0.34	0.51	0.69	120.4	9.90	0.29	0.49	0.70	106.7	11.08	0.26	0.47	0.67
	6240	150.3	7.88	0.38	0.56	0.74	136.6	8.89	0.36	0.56	0.72	122.1	9.98	0.32	0.56	0.72	107.9	11.17	0.27	0.53	0.71

15 TON - HIGH EFFICIENCY LGT180H5 WITH HUMIDITROL® OPERATING (2 COMPRESSORS - PART LOAD)

Entering Wet Bulb Temperature	Total Air Volume	Outdoor Air Temperature Entering Outdoor Coil																			
		65°F					75°F					85°F					95°F				
		Total Cool Cap.	Comp. Motor Input	Sensible To Total Ratio (S/T)			Total Cool Cap.	Comp. Motor Input	Sensible To Total Ratio (S/T)			Total Cool Cap.	Comp. Motor Input	Sensible To Total Ratio (S/T)			Total Cool Cap.	Comp. Motor Input	Sensible To Total Ratio (S/T)		
				Dry Bulb					Dry Bulb					Dry Bulb					Dry Bulb		
cfm	kBtuh	kW	75°F	80°F	85°F	kBtuh	kW	75°F	80°F	85°F	kBtuh	kW	75°F	80°F	85°F	kBtuh	kW	75°F	80°F	85°F	
63°F	2400	69.3	4.53	0.51	0.67	0.83	53.8	5.26	0.42	0.65	0.84	38.6	5.95	0.27	0.59	0.86	22.7	6.65	-0.11	0.47	0.91
	3000	75.2	4.58	0.50	0.69	0.86	58.3	5.32	0.42	0.69	0.88	40.6	6.01	0.26	0.66	0.92	23.4	6.72	-0.13	0.58	1.00
	3600	80.5	4.61	0.54	0.75	0.90	62.5	5.36	0.46	0.72	0.93	43.6	6.06	0.32	0.70	0.98	24.5	6.77	-0.08	0.66	1.00
67°F	2400	79.5	4.59	0.29	0.45	0.60	63.8	5.33	0.18	0.38	0.57	48.6	6.02	0.00	0.27	0.51	32.6	6.73	-0.36	0.06	0.42
	3000	86.7	4.64	0.30	0.48	0.65	70.1	5.39	0.19	0.41	0.63	52.5	6.09	0.02	0.29	0.59	34.7	6.80	-0.40	0.08	0.49
	3600	93.1	4.67	0.32	0.50	0.70	73.9	5.42	0.20	0.44	0.68	55.0	6.13	0.02	0.36	0.64	35.6	6.85	-0.40	0.15	0.58
71°F	2400	90.7	4.65	0.14	0.29	0.43	75.6	5.40	0.02	0.19	0.37	59.9	6.10	-0.16	0.06	0.27	44.3	6.82	-0.49	-0.16	0.14
	3000	98.9	4.70	0.14	0.30	0.45	82.1	5.46	0.01	0.22	0.40	64.2	6.16	-0.18	0.06	0.31	46.1	6.88	-0.56	-0.17	0.17
	3600	104.4	4.72	0.14	0.33	0.49	86.3	5.49	0.00	0.23	0.44	67.0	6.20	-0.21	0.09	0.36	47.5	6.92	-0.60	-0.16	0.23

15 TON HIGH EFFICIENCY LGT180H5 WITH HUMIDITROL® OPERATING (3 COMPRESSORS - FULL LOAD)

Entering Wet Bulb Temperature	Total Air Volume	Outdoor Air Temperature Entering Outdoor Coil																			
		65°F					75°F					85°F					95°F				
		Total Cool Cap.	Comp. Motor Input	Sensible To Total Ratio (S/T)			Total Cool Cap.	Comp. Motor Input	Sensible To Total Ratio (S/T)			Total Cool Cap.	Comp. Motor Input	Sensible To Total Ratio (S/T)			Total Cool Cap.	Comp. Motor Input	Sensible To Total Ratio (S/T)		
				Dry Bulb					Dry Bulb					Dry Bulb					Dry Bulb		
cfm	kBtuh	kW	75°F	80°F	85°F	kBtuh	kW	75°F	80°F	85°F	kBtuh	kW	75°F	80°F	85°F	kBtuh	kW	75°F	80°F	85°F	
63°F	4800	130.4	6.87	0.56	0.70	0.83	105.9	8.03	0.50	0.69	0.85	80.9	9.13	0.41	0.67	0.87	55.7	10.29	0.28	0.63	0.91
	6000	141.7	6.93	0.59	0.76	0.90	114.6	8.09	0.56	0.76	0.92	87.5	9.21	0.50	0.76	0.96	60.5	10.38	0.35	0.75	1.00
	7200	151.1	6.97	0.64	0.82	0.94	122.9	8.15	0.62	0.82	0.97	93.1	9.27	0.57	0.83	1.00	63.7	10.45	0.46	0.87	1.00
67°F	4800	144.6	6.94	0.39	0.54	0.68	120.0	8.10	0.31	0.50	0.66	94.3	9.21	0.21	0.46	0.65	68.9	10.38	0.02	0.35	0.61
	6000	155.1	6.98	0.42	0.61	0.74	127.8	8.16	0.36	0.57	0.73	100.5	9.28	0.25	0.53	0.73	73.0	10.45	0.07	0.43	0.72
	7200	163.0	7.01	0.48	0.66	0.79	134.5	8.19	0.41	0.63	0.80	105.0	9.33	0.30	0.60	0.80	75.0	10.50	0.09	0.54	0.82
71°F	4800	160.0	7.00	0.25	0.40	0.54	134.9	8.17	0.17	0.34	0.50	109.9	9.30	0.06	0.25	0.45	84.0	10.47	-0.18	0.13	0.39
	6000	171.3	7.04	0.29	0.44	0.59	143.4	8.22	0.20	0.38	0.57	116.2	9.35	0.06	0.31	0.52	87.1	10.53	-0.18	0.17	0.45
	7200	179.0	7.06	0.30	0.48	0.66	149.6	8.25	0.24	0.43	0.62	120.3	9.39	0.07	0.35	0.58	89.9	10.58	-0.18	0.20	0.54

HUMIDITROL® DEHUMIDIFICATION SYSTEM RATINGS

17.5 TON - HIGH EFFICIENCY LGT210H5 WITH HUMIDITROL® OPERATING (2 COMPRESSORS - PART LOAD)

Entering Wet Bulb Temperature	Total Air Volume	Outdoor Air Temperature Entering Outdoor Coil																			
		65°F					75°F					85°F					95°F				
		Total Cool Cap.	Comp. Motor Input	Sensible To Total Ratio (S/T)			Total Cool Cap.	Comp. Motor Input	Sensible To Total Ratio (S/T)			Total Cool Cap.	Comp. Motor Input	Sensible To Total Ratio (S/T)			Total Cool Cap.	Comp. Motor Input	Sensible To Total Ratio (S/T)		
				Dry Bulb					Dry Bulb					Dry Bulb					Dry Bulb		
cfm	kBtuh	kW	75°F	80°F	85°F	kBtuh	kW	75°F	80°F	85°F	kBtuh	kW	75°F	80°F	85°F	kBtuh	kW	75°F	80°F	85°F	
63°F	2800	66.4	4.11	0.61	0.78	0.93	49.3	4.56	0.55	0.79	0.99	32.3	5.10	0.43	0.80	1.00	15.2	5.76	-0.02	0.85	1.00
	3500	72.5	4.16	0.65	0.84	1.00	53.6	4.62	0.61	0.86	1.00	35.0	5.17	0.51	0.91	1.00	15.7	5.82	0.11	1.00	1.00
	4200	77.3	4.20	0.69	0.90	1.00	56.9	4.67	0.66	0.94	1.00	36.6	5.22	0.59	1.00	1.00	16.2	5.88	0.26	1.00	1.00
67°F	2800	75.3	4.17	0.43	0.59	0.75	58.1	4.62	0.33	0.55	0.74	40.8	5.17	0.15	0.47	0.74	23.7	5.82	-0.31	0.26	0.74
	3500	81.4	4.21	0.45	0.64	0.80	62.4	4.68	0.36	0.60	0.82	43.3	5.23	0.17	0.53	0.83	24.1	5.89	-0.36	0.36	0.89
	4200	85.8	4.25	0.48	0.68	0.86	65.6	4.72	0.38	0.65	0.88	44.7	5.28	0.20	0.61	0.94	24.0	5.94	-0.36	0.48	1.00
71°F	2800	85.3	4.22	0.28	0.44	0.58	67.9	4.68	0.16	0.36	0.54	50.6	5.24	-0.05	0.23	0.48	32.9	5.90	-0.50	-0.02	0.35
	3500	91.8	4.27	0.28	0.47	0.63	72.7	4.74	0.15	0.39	0.59	52.6	5.30	-0.06	0.26	0.54	33.0	5.96	-0.54	-0.01	0.44
	4200	96.5	4.31	0.29	0.49	0.67	76.1	4.79	0.16	0.42	0.65	54.1	5.35	-0.06	0.30	0.61	33.2	6.01	-0.59	0.02	0.53

17.5 TON - HIGH EFFICIENCY LGT210H5 WITH HUMIDITROL® OPERATING (4 COMPRESSORS - FULL LOAD))

Entering Wet Bulb Temperature	Total Air Volume	Outdoor Air Temperature Entering Outdoor Coil																			
		65°F					75°F					85°F					95°F				
		Total Cool Cap.	Comp. Motor Input	Sensible To Total Ratio (S/T)			Total Cool Cap.	Comp. Motor Input	Sensible To Total Ratio (S/T)			Total Cool Cap.	Comp. Motor Input	Sensible To Total Ratio (S/T)			Total Cool Cap.	Comp. Motor Input	Sensible To Total Ratio (S/T)		
				Dry Bulb					Dry Bulb					Dry Bulb					Dry Bulb		
cfm	kBtuh	kW	75°F	80°F	85°F	kBtuh	kW	75°F	80°F	85°F	kBtuh	kW	75°F	80°F	85°F	kBtuh	kW	75°F	80°F	85°F	
63°F	5600	163.3	8.04	0.63	0.83	0.95	135.6	9.17	0.60	0.85	0.98	107.9	10.48	0.59	0.87	1.00	80.5	12.01	0.52	0.93	1.00
	7000	175.7	8.09	0.68	0.89	0.99	146.6	9.24	0.68	0.92	1.00	116.8	10.57	0.65	0.94	1.00	86.5	12.10	0.64	1.00	1.00
	8400	185.5	8.14	0.74	0.92	1.00	154.3	9.30	0.72	0.96	1.00	122.9	10.64	0.72	1.00	1.00	91.1	12.18	0.72	1.00	1.00
67°F	5600	180.4	8.09	0.45	0.61	0.78	152.3	9.24	0.39	0.59	0.79	124.6	10.57	0.29	0.56	0.81	96.2	12.10	0.16	0.54	0.84
	7000	192.0	8.15	0.46	0.66	0.86	161.8	9.31	0.41	0.66	0.88	131.4	10.65	0.35	0.63	0.88	100.5	12.18	0.22	0.62	0.92
	8400	200.4	8.20	0.49	0.72	0.89	168.6	9.37	0.44	0.70	0.91	136.3	10.71	0.35	0.71	0.95	103.3	12.25	0.21	0.72	1.00
71°F	5600	198.3	8.16	0.27	0.44	0.58	170.0	9.32	0.21	0.39	0.57	141.5	10.66	0.09	0.34	0.54	111.8	12.20	-0.07	0.23	0.52
	7000	209.4	8.22	0.27	0.45	0.64	179.0	9.40	0.21	0.41	0.63	148.0	10.74	0.09	0.36	0.62	116.6	12.29	-0.08	0.26	0.59
	8400	217.7	8.27	0.26	0.47	0.69	185.5	9.45	0.20	0.45	0.69	153.0	10.81	0.08	0.38	0.67	120.3	12.37	-0.12	0.33	0.68

20 TON - HIGH EFFICIENCY LGT240H5 WITH HUMIDITROL® OPERATING (2 COMPRESSORS - PART LOAD)

Entering Wet Bulb Temperature	Total Air Volume	Outdoor Air Temperature Entering Outdoor Coil																			
		65°F					75°F					85°F					95°F				
		Total Cool Cap.	Comp. Motor Input	Sensible To Total Ratio (S/T)			Total Cool Cap.	Comp. Motor Input	Sensible To Total Ratio (S/T)			Total Cool Cap.	Comp. Motor Input	Sensible To Total Ratio (S/T)			Total Cool Cap.	Comp. Motor Input	Sensible To Total Ratio (S/T)		
				Dry Bulb					Dry Bulb					Dry Bulb					Dry Bulb		
cfm	kBtuh	kW	75°F	80°F	85°F	kBtuh	kW	75°F	80°F	85°F	kBtuh	kW	75°F	80°F	85°F	kBtuh	kW	75°F	80°F	85°F	
63°F	3200	81.8	4.92	0.53	0.70	0.86	62.5	5.59	0.45	0.68	0.87	43.7	6.28	0.30	0.63	0.91	25.5	7.02	-0.05	0.53	0.98
	4000	86.9	4.97	0.58	0.77	0.93	66.5	5.66	0.51	0.76	0.95	46.3	6.35	0.38	0.75	0.99	26.7	7.09	0.07	0.75	1.00
	4800	90.9	5.02	0.62	0.84	0.95	69.0	5.70	0.56	0.85	0.97	48.2	6.40	0.46	0.86	0.99	27.2	7.13	0.18	0.93	1.00
67°F	3200	93.5	4.98	0.37	0.54	0.68	74.0	5.66	0.26	0.47	0.66	54.5	6.35	0.07	0.37	0.62	35.7	7.09	-0.30	0.16	0.55
	4000	99.0	5.04	0.39	0.58	0.75	77.6	5.72	0.29	0.53	0.74	56.9	6.41	0.10	0.44	0.72	37.1	7.15	-0.27	0.26	0.70
	4800	102.6	5.08	0.42	0.62	0.81	79.4	5.76	0.31	0.58	0.81	57.5	6.45	0.13	0.50	0.83	36.0	7.19	-0.26	0.35	0.85
71°F	3200	104.7	5.04	0.25	0.39	0.54	84.3	5.73	0.11	0.30	0.48	65.3	6.42	-0.09	0.17	0.40	45.9	7.16	-0.47	-0.07	0.27
	4000	111.0	5.10	0.26	0.42	0.58	88.7	5.78	0.12	0.33	0.53	68.3	6.48	-0.09	0.20	0.47	47.0	7.21	-0.48	-0.03	0.36
	4800	114.9	5.13	0.26	0.45	0.63	91.8	5.82	0.12	0.37	0.59	69.4	6.52	-0.10	0.23	0.53	47.4	7.25	-0.51	0.00	0.44

20 TON - HIGH EFFICIENCY LGT240H5 WITH HUMIDITROL® OPERATING (4 COMPRESSORS - FULL LOAD)

Entering Wet Bulb Temperature	Total Air Volume	Outdoor Air Temperature Entering Outdoor Coil																			
		65°F					75°F					85°F					95°F				
		Total Cool Cap.	Comp. Motor Input	Sensible To Total Ratio (S/T)			Total Cool Cap.	Comp. Motor Input	Sensible To Total Ratio (S/T)			Total Cool Cap.	Comp. Motor Input	Sensible To Total Ratio (S/T)			Total Cool Cap.	Comp. Motor Input	Sensible To Total Ratio (S/T)		
				Dry Bulb					Dry Bulb					Dry Bulb					Dry Bulb		
cfm	kBtuh	kW	75°F	80°F	85°F	kBtuh	kW	75°F	80°F	85°F	kBtuh	kW	75°F	80°F	85°F	kBtuh	kW	75°F	80°F	85°F	
63°F	6400	191.3	9.43	0.59	0.77	0.88	162.7	10.97	0.54	0.77	0.89	133.9	12.51	0.51	0.75	0.91	106.2	14.12	0.42	0.74	0.93
	8000	201.6	9.49	0.63	0.83	0.95	170.8	11.04	0.61	0.83	0.97	140.8	12.58	0.59	0.83	0.99	111.8	14.20	0.53	0.84	1.00
	9600	209.4	9.54	0.69	0.88	0.99	177.3	11.10	0.69	0.89	1.00	145.3	12.64	0.64	0.90	1.00	114.6	14.25	0.62	0.93	1.00
67°F	6400	209.5	9.49	0.41	0.58	0.74	179.6	11.04	0.34	0.53	0.74	150.0	12.58	0.26	0.50	0.74	121.1	14.19	0.12	0.44	0.71
	8000	218.5	9.55	0.42	0.62	0.81	186.5	11.10	0.36	0.60	0.80	154.6	12.64	0.27	0.59	0.80	124.1	14.25	0.15	0.54	0.81
	9600	224.1	9.59	0.44	0.69	0.86	190.5	11.14	0.39	0.69	0.86	157.4	12.69	0.29	0.65	0.87	125.4	14.29	0.20	0.65	0.89
71°F	6400	229.3	9.56	0.26	0.41	0.56	198.7	11.12	0.17	0.35	0.52	168.0	12.66	0.06	0.28	0.50	137.9	14.27	-0.10	0.19	0.45
	8000	238.1	9.61	0.24	0.44	0.61	205.2	11.17	0.14	0.38	0.60	171.6	12.71	0.04	0.31	0.57	140.4	14.32	-0.12	0.22	0.53
	9600	243.6	9.64	0.23	0.46	0.67	208.1	11.20	0.14	0.40	0.66	174.3	12.75	0.02	0.35	0.66	141.6	14.36	-0.13	0.26	0.63

HUMIDITROL® DEHUMIDIFICATION SYSTEM RATINGS

25 TON - STANDARD EFFICIENCY LGT300H5 WITH HUMIDITROL® OPERATING (2 COMPRESSORS - PART LOAD)

Entering Wet Bulb Temperature	Total Air Volume	Outdoor Air Temperature Entering Outdoor Coil																			
		65°F					75°F					85°F					95°F				
		Total Cool Cap.	Comp. Motor Input	Sensible To Total Ratio (S/T)			Total Cool Cap.	Comp. Motor Input	Sensible To Total Ratio (S/T)			Total Cool Cap.	Comp. Motor Input	Sensible To Total Ratio (S/T)			Total Cool Cap.	Comp. Motor Input	Sensible To Total Ratio (S/T)		
				Dry Bulb					Dry Bulb					Dry Bulb					Dry Bulb		
cfm	kBtuh	kW	75°F	80°F	85°F	kBtuh	kW	75°F	80°F	85°F	kBtuh	kW	75°F	80°F	85°F	kBtuh	kW	75°F	80°F	85°F	
63°F	4000	92.7	6.62	0.54	0.72	0.87	73.7	7.22	0.47	0.69	0.88	54.2	7.92	0.33	0.64	0.90	34.6	8.75	0.03	0.55	0.94
	4750	97.1	6.77	0.58	0.76	0.92	76.7	7.37	0.51	0.75	0.94	56.1	8.07	0.39	0.72	0.97	35.1	8.91	0.09	0.67	1.00
	5500	100.5	6.89	0.61	0.81	0.96	78.9	7.49	0.55	0.80	0.97	56.9	8.20	0.43	0.80	0.99	35.0	9.03	0.14	0.79	1.00
67°F	4000	102.6	6.78	0.37	0.54	0.69	84.1	7.40	0.27	0.48	0.67	63.6	8.08	0.11	0.39	0.63	43.8	8.92	-0.22	0.20	0.56
	4750	106.9	6.92	0.39	0.58	0.74	86.0	7.52	0.29	0.52	0.73	65.1	8.22	0.12	0.43	0.70	43.8	9.06	-0.22	0.26	0.66
	5500	109.7	7.03	0.40	0.61	0.78	87.6	7.63	0.30	0.56	0.78	65.7	8.34	0.13	0.48	0.77	43.6	9.18	-0.22	0.32	0.76
71°F	4000	114.5	6.97	0.23	0.40	0.54	94.7	7.57	0.11	0.32	0.49	74.9	8.28	-0.08	0.19	0.42	55.0	9.13	-0.41	-0.02	0.29
	4750	118.5	7.11	0.22	0.41	0.57	97.7	7.72	0.10	0.33	0.53	76.7	8.43	-0.10	0.21	0.46	55.3	9.27	-0.46	-0.01	0.35
	5500	121.4	7.21	0.22	0.43	0.61	99.7	7.83	0.08	0.35	0.57	76.2	8.52	-0.12	0.22	0.51	55.0	9.40	-0.50	0.00	0.40

25 TON - STANDARD EFFICIENCY LGT300H5 WITH HUMIDITROL® OPERATING (4 COMPRESSORS - FULL LOAD)

Entering Wet Bulb Temperature	Total Air Volume	Outdoor Air Temperature Entering Outdoor Coil																			
		65°F					75°F					85°F					95°F				
		Total Cool Cap.	Comp. Motor Input	Sensible To Total Ratio (S/T)			Total Cool Cap.	Comp. Motor Input	Sensible To Total Ratio (S/T)			Total Cool Cap.	Comp. Motor Input	Sensible To Total Ratio (S/T)			Total Cool Cap.	Comp. Motor Input	Sensible To Total Ratio (S/T)		
				Dry Bulb					Dry Bulb					Dry Bulb					Dry Bulb		
cfm	kBtuh	kW	75°F	80°F	85°F	kBtuh	kW	75°F	80°F	85°F	kBtuh	kW	75°F	80°F	85°F	kBtuh	kW	75°F	80°F	85°F	
63°F	8000	237.2	13.81	0.61	0.79	0.89	205.5	15.43	0.58	0.77	0.90	174.0	17.22	0.54	0.77	0.92	143.0	19.26	0.49	0.76	0.94
	9500	237.3	13.96	0.64	0.81	0.93	203.1	15.60	0.62	0.81	0.95	170.5	17.42	0.58	0.81	0.98	137.8	19.46	0.55	0.82	1.00
	11000	235.4	14.08	0.67	0.84	0.98	199.2	15.73	0.66	0.85	1.00	165.1	17.57	0.62	0.86	1.00	131.9	19.63	0.59	0.87	1.00
67°F	8000	258.7	13.98	0.45	0.60	0.76	227.0	15.62	0.40	0.58	0.74	192.9	17.42	0.34	0.55	0.74	159.6	19.46	0.24	0.51	0.73
	9500	259.0	14.09	0.45	0.63	0.79	220.2	15.74	0.39	0.60	0.78	186.8	17.58	0.33	0.59	0.78	154.5	19.65	0.23	0.56	0.78
	11000	252.9	14.18	0.43	0.65	0.82	217.7	15.87	0.40	0.65	0.82	181.8	17.72	0.32	0.62	0.83	147.0	19.80	0.21	0.61	0.84
71°F	8000	288.2	14.18	0.30	0.45	0.58	253.3	15.87	0.24	0.41	0.56	219.2	17.72	0.14	0.36	0.54	183.0	19.77	0.04	0.29	0.51
	9500	287.0	14.29	0.28	0.46	0.60	250.1	16.00	0.21	0.42	0.59	211.1	17.85	0.14	0.35	0.57	179.0	19.96	0.00	0.29	0.53
	11000	280.1	14.38	0.27	0.45	0.64	244.4	16.10	0.18	0.40	0.62	206.7	17.98	0.07	0.34	0.62	167.0	20.05	-0.07	0.26	0.59

BLOWER DATA

BLOWER TABLE INCLUDES RESISTANCE FOR BASE UNIT ONLY WITH DRY INDOOR COIL & AIR FILTERS IN PLACE FOR ALL UNITS ADD:

- 1 - Wet indoor coil air resistance of selected unit.
- 2 - Any factory installed options air resistance (heat section, economizer, etc.)
- 3 - Any field installed accessories air resistance (heat section, duct resistance, diffuser, etc.)

Then determine from blower table blower motor output and drive required.

See page 50 for wet coil, option/accessory air resistance data, and factory installed drive kit specifications.

Minimum Air Volume Required For Different Gas Heat Sizes:

Low Heat - 3000 cfm | Standard and Medium Heat - 4500 cfm | High Heat - 5125 cfm

TOTAL STATIC PRESSURE - Inches Water Gauge (Pa)

Air Volume cfm	0.20		0.40		0.60		0.80		1.00		1.20		1.40		1.60		1.80		2.00		2.20		2.40		2.60			
	RPM	BHP	RPM	BHP	RPM	BHP	RPM	BHP	RPM	BHP	RPM	BHP	RPM	BHP	RPM	BHP	RPM	BHP	RPM	BHP	RPM	BHP	RPM	BHP	RPM	BHP	RPM	BHP
2750	385	0.30	505	0.50	600	0.70	680	0.90	755	1.10	820	1.30	885	1.70	950	2.10	1005	2.55	1060	3.00	1110	3.30	1160	3.85	1205	4.15	1250	4.45
3000	395	0.35	515	0.55	610	0.75	685	1.00	760	1.20	825	1.45	890	1.85	955	2.25	1010	2.70	1065	3.15	1115	3.45	1165	4.10	1210	4.45	1255	4.75
3250	405	0.40	520	0.60	615	0.85	695	1.10	765	1.30	830	1.60	890	2.00	955	2.40	1010	2.85	1065	3.30	1115	3.60	1165	4.35	1210	4.65	1255	4.95
3500	415	0.45	530	0.70	620	0.95	700	1.20	775	1.45	840	1.70	900	2.15	965	2.55	1020	3.00	1075	3.45	1125	3.75	1175	4.50	1220	4.80	1265	5.10
3750	425	0.50	540	0.75	630	1.05	710	1.30	780	1.60	845	1.85	905	2.30	970	2.70	1025	3.15	1080	3.60	1130	3.90	1180	4.65	1225	4.95	1270	5.25
4000	435	0.55	545	0.85	635	1.10	715	1.40	785	1.70	850	2.00	910	2.45	975	2.85	1030	3.30	1085	3.75	1135	4.05	1185	4.80	1230	5.10	1275	5.40
4250	445	0.60	555	0.90	645	1.25	725	1.55	795	1.85	860	2.15	920	2.65	985	3.05	1040	3.50	1095	3.90	1145	4.25	1195	5.00	1240	5.30	1285	5.60
4500	455	0.70	565	1.00	655	1.35	730	1.65	800	2.00	865	2.35	925	2.85	990	3.25	1045	3.70	1100	4.10	1150	4.40	1200	5.15	1245	5.45	1290	5.75
4750	470	0.75	575	1.10	660	1.45	740	1.80	810	2.15	875	2.50	930	3.05	995	3.45	1050	3.90	1105	4.30	1155	4.60	1205	5.40	1250	5.70	1295	6.00
5000	480	0.85	585	1.25	670	1.60	750	1.95	815	2.30	880	2.70	940	3.25	1000	3.65	1060	4.00	1110	4.40	1160	4.70	1210	5.45	1255	5.75	1300	6.05
5250	495	0.95	595	1.35	680	1.70	755	2.10	825	2.50	890	2.90	945	3.35	1005	3.85	1065	4.20	1115	4.60	1165	4.90	1215	5.60	1260	5.90	1305	6.20
5500	505	1.05	605	1.45	690	1.85	765	2.25	835	2.65	895	3.05	955	3.45	1015	3.95	1075	4.40	1125	4.80	1175	5.10	1225	5.85	1270	6.15	1315	6.45
5750	520	1.15	615	1.60	700	2.00	775	2.45	840	2.85	905	3.25	960	3.65	1020	4.10	1080	4.50	1130	4.90	1180	5.20	1230	6.00	1275	6.30	1320	6.60
6000	530	1.30	630	1.75	710	2.15	785	2.60	850	3.05	910	3.45	970	3.90	1030	4.35	1090	4.80	1140	5.20	1190	5.50	1240	6.25	1285	6.55	1330	6.85
6250	545	1.40	640	1.90	720	2.35	795	2.80	860	3.25	920	3.70	975	4.15	1035	4.60	1095	5.05	1145	5.40	1195	5.70	1245	6.45	1290	6.75	1335	7.05
6500	560	1.55	650	2.05	730	2.50	805	3.00	870	3.45	930	3.95	985	4.40	1040	4.85	1095	5.30	1145	5.70	1195	6.00	1245	6.75	1290	7.05	1335	7.35
6750	570	1.70	665	2.20	745	2.70	815	3.20	880	3.70	940	4.20	995	4.65	1045	5.10	1095	5.60	1145	6.00	1195	6.30	1245	7.10	1290	7.40	1335	7.70
7000	585	1.85	675	2.35	755	2.90	825	3.40	890	3.95	950	4.45	1005	4.95	1055	5.40	1105	5.95	1155	6.30	1205	6.60	1255	7.45	1300	7.75	1340	8.05
7250	600	2.00	690	2.60	765	3.10	835	3.65	900	4.15	955	4.65	1015	5.25	1065	5.75	1115	6.25	1165	6.70	1215	7.00	1265	7.85	1310	8.15	1350	8.45
7500	615	2.20	700	2.75	775	3.30	845	3.85	910	4.45	965	4.95	1020	5.50	1070	6.05	1120	6.55	1170	7.05	1220	7.30	1270	8.15	1315	8.45	1355	8.75
7750	630	2.40	715	3.00	790	3.55	855	4.10	920	4.70	975	5.25	1030	5.80	1080	6.35	1130	6.85	1180	7.35	1230	7.60	1280	8.45	1325	8.75	1365	9.05
8000	640	2.55	725	3.20	800	3.80	865	4.35	930	4.95	985	5.50	1040	6.10	1090	6.70	1140	7.20	1190	7.70	1240	8.00	1290	8.85	1335	9.15	1375	9.45
8250	655	2.80	740	3.40	810	4.00	880	4.65	940	5.25	995	5.85	1050	6.45	1100	7.05	1150	7.65	1200	8.15	1250	8.40	1300	9.25	1345	9.55	1385	9.85
8500	670	3.00	750	3.65	825	4.30	890	4.90	950	5.55	1005	6.15	1060	6.80	1110	7.40	1160	8.05	1210	8.55	1260	8.80	1310	9.65	1355	9.95	1395	10.25
8750	685	3.25	765	3.90	835	4.55	900	5.20	960	5.85	1015	6.45	1070	7.15	1120	7.75	1170	8.35	1220	8.85	1270	9.10	1320	9.95	1365	10.25	1405	10.55
9000	700	3.50	780	4.20	850	4.85	910	5.50	970	6.15	1025	6.80	1080	7.50	1130	8.15	1180	8.75	1230	9.25	1280	9.50	1330	10.30	1375	10.60	1415	10.90
9250	715	3.75	790	4.45	860	5.15	925	5.85	985	6.55	1040	7.20	1095	7.85	1140	8.55	1190	9.15	1240	9.65	1290	9.90	1340	10.55	1385	10.80	1425	11.15
9500	730	4.00	805	4.75	875	5.45	935	6.15	995	6.90	1050	7.60	1105	8.25	1150	8.95	1195	9.60	1245	10.10	1295	10.35	1345	10.90	1390	11.15	1430	11.40
9750	745	4.30	820	5.05	885	5.75	950	6.55	1005	7.20	1060	7.95	1110	8.65	1160	9.40	1205	10.05	1255	10.55	1305	10.80	1355	11.15	1400	11.40	1440	11.70
10,000	760	4.60	835	5.40	900	6.15	960	6.85	1015	7.60	1070	8.35	1120	9.05	1170	9.80	1215	10.50	1265	11.00	1315	11.25	1365	11.40	1410	11.70	1450	12.00
10,250	775	4.90	845	5.65	910	6.45	970	7.20	1030	8.00	1080	8.75	1135	9.55	1180	10.25	1230	11.00	1280	11.50	1330	11.75	1380	11.90	1430	12.00	1470	12.30
10,500	790	5.20	860	6.00	925	6.85	985	7.65	1040	8.40	1095	9.20	1145	10.00	1190	10.75	1240	11.50	1290	12.00	1340	12.25	1390	12.30	1440	12.60	1480	12.90
10,750	805	5.55	875	6.40	940	7.25	1000	8.05	1055	8.85	1105	9.65	1155	10.45	1200	11.25	1250	12.00	1300	12.50	1350	12.75	1400	12.80	1450	13.00	1490	13.20
11,000	820	5.90	890	6.80	950	7.60	1010	8.45	1065	9.30	1115	10.05	1165	10.85	1210	11.65	1260	12.50	1310	13.00	1410	13.25	1460	13.30	1510	13.50	1550	13.80

BLOWER DATA

FACTORY INSTALLED BELT DRIVE KIT SPECIFICATIONS

Nominal HP	Maximum HP	Drive Kit Number	RPM Range
3	3.45	1	535 - 725
3	3.45	2	710 - 965
5	5.75	3	685 - 856
5	5.75	4	850 - 1045
5	5.75	5	945 - 1185
7.5	8.63	6	850 - 1045
7.5	8.63	7	945 - 1185
7.5	8.63	8	1045 - 1285
10	11.50	7	945 - 1185
10	11.50	10	1045 - 1285
10	11.50	11	1135 - 1330

NOTE - Using total air volume and system static pressure requirements determine from blower performance tables rpm and motor output required. Maximum usable output of motors furnished are shown. In Canada, nominal motor output is also maximum usable motor output. If motors of comparable output are used, be sure to keep within the service factor limitations outlined on the motor nameplate.

NOTE - All units are limited to a motor service factor of 1.0.

FACTORY INSTALLED OPTIONS/FIELD INSTALLED ACCESSORY AIR RESISTANCE

Air Volume cfm	Wet Indoor Coil		Humiditrol® Reheat Coil	Gas Heat Exchanger			Economizer	Filters			Horizontal Roof Curb	
	156, 180	210, 240, 300		Low/Standard Heat	Medium Heat	High Heat		MERV 8	MERV 13	MERV 16	156 thru 240	300
	in. w.g.	in. w.g.	in. w.g.	in. w.g.	in. w.g.	in. w.g.	in. w.g.				in. w.g.	in. w.g.
2750	.01	.02	.01	.02	.04	.05	---	.01	.03	.06	.03	-
3000	.01	.02	.01	.03	.04	.05	---	.01	.03	.06	.04	-
3250	.01	.03	.01	.03	.05	.06	---	.01	.04	.07	.04	.01
3500	.01	.03	.02	.03	.05	.06	---	.01	.04	.08	.05	.01
3750	.01	.03	.02	.04	.06	.07	---	.01	.04	.08	.05	.01
4000	.02	.04	.02	.04	.06	.07	---	.01	.04	.09	.06	.02
4250	.02	.04	.02	.04	.06	.08	---	.01	.05	.10	.07	.02
4500	.02	.05	.02	.05	.07	.09	---	.01	.05	.10	.07	.02
4750	.02	.05	.02	.05	.08	.10	---	.02	.05	.11	.08	.03
5000	.02	.05	.02	.05	.09	.11	---	.02	.06	.12	.08	.03
5250	.02	.06	.03	.06	.10	.12	---	.02	.06	.12	.09	.04
5500	.02	.07	.03	.06	.10	.13	---	.02	.06	.13	.10	.04
5750	.03	.07	.03	.06	.11	.14	---	.02	.07	.14	.11	.05
6000	.03	.08	.03	.07	.12	.15	---	.03	.07	.14	.11	.06
6250	.03	.08	.03	.07	.12	.16	.01	.03	.07	.15	.12	.07
6500	.03	.09	.04	.08	.13	.17	.02	.03	.08	.16	.13	.08
6750	.04	.10	.04	.08	.14	.18	.03	.03	.08	.17	.14	.08
7000	.04	.10	.04	.09	.15	.19	.04	.04	.08	.17	.15	.09
7250	.04	.11	.04	.09	.16	.20	.05	.04	.09	.18	.16	.10
7500	.05	.12	.05	.10	.17	.21	.06	.04	.09	.19	.17	.11
8000	.05	.13	.05	.11	.19	.24	.09	.05	.10	.21	.19	.13
8500	.06	.15	.05	.12	.20	.26	.11	.05	.10	.22	.21	.15
9000	.07	.16	.06	.13	.23	.29	.14	.06	.11	.24	.24	.17
9500	.08	.18	.07	.14	.25	.32	.16	.07	.12	.25	.26	.19
10,000	.08	.20	.07	.16	.27	.35	.19	.07	.12	.27	.29	.21
10,500	.09	.22	.08	.17	.30	.38	.22	.08	.13	.29	.31	.24
11,000	.11	.24	.08	.18	.31	.40	.25	.09	.14	.30	.34	.27

BLOWER DATA

POWER EXHAUST FAN PERFORMANCE

Return Air System Static Pressure	Air Volume Exhausted
in. w.g.	cfm
0.00	8630
0.05	8210
0.10	7725
0.15	7110
0.20	6470
0.25	5790
0.30	5060
0.35	4300
0.40	3510
0.45	2690
0.50	1840

CEILING DIFFUSER AIR RESISTANCE - in. w.g.

Air Volume cfm	Step-Down Diffuser						Flush Diffuser	
	RTD11-185S			RTD11-275S			FD11-185S	FD11-275S
	2 Ends Open	1 Side/2 Ends Open	All Ends & Sides Open	2 Ends Open	1 Side/2 Ends Open	All Ends & Sides Open		
5000	.51	.44	.39	---	---	---	.27	---
5200	.56	.48	.42	---	---	---	.30	---
5400	.61	.52	.45	---	---	---	.33	---
5600	.66	.56	.48	---	---	---	.36	---
5800	.71	.59	.51	---	---	---	.39	---
6000	.76	.63	.55	.36	.31	.27	.42	.29
6200	.80	.68	.59	---	---	---	.46	---
6400	.86	.72	.63	---	---	---	.50	---
6500	---	---	---	.42	.36	.31	---	.34
6600	.92	.77	.67	---	---	---	.54	---
6800	.99	.83	.72	---	---	---	.58	---
7000	1.03	.87	.76	.49	.41	.36	.62	.40
7200	1.09	.92	.80	---	---	---	.66	---
7400	1.15	.97	.84	---	---	---	.70	---
7500	---	---	---	.51	.46	.41	---	.45
7600	1.20	1.02	.88	---	---	---	.74	---
8000	---	---	---	.59	.49	.43	---	.50
8500	---	---	---	.69	.58	.50	---	.57
9000	---	---	---	.79	.67	.58	---	.66
9500	---	---	---	.89	.75	.65	---	.74
10,000	---	---	---	1.00	.84	.73	---	.81
10,500	---	---	---	1.10	.92	.80	---	.89
11,000	---	---	---	1.21	1.01	.88	---	.96

CEILING DIFFUSER AIR THROW DATA - ft.

Model No.	Air Volume cfm	¹ Effective Throw Range - ft.		Model No.	Air Volume cfm	¹ Effective Throw Range - ft.	
		RTD11-185S Step-Down	FD11-185S Flush			RTD11-275S Step-Down	FD11-275S Flush
156 180	5600	39 - 49	28 - 37	210 240 300	7200	33 - 38	26 - 35
	5800	42 - 51	29 - 38		7400	35 - 40	28 - 37
	6000	44 - 54	40 - 50		7600	36 - 41	29 - 38
	6200	45 - 55	42 - 51		7800	38 - 43	40 - 50
	6400	46 - 55	43 - 52		8000	39 - 44	42 - 51
	6600	47 - 56	45 - 56		8200	41 - 46	43 - 52
					8400	43 - 49	44 - 54
					8600	44 - 50	46 - 57
					8800	47 - 55	48 - 59

¹ Throw is the horizontal or vertical distance an airstream travels on leaving the outlet or diffuser before the maximum velocity is reduced to 50 ft. per minute. Four sides open.

ELECTRICAL DATA
13 TON

Model		LGT156H5					
¹ Voltage - 60Hz		208/230V - 3 Ph		460V - 3 Ph		575V - 3 Ph	
Compressor 1 (Non-Inverter)	Rated Load Amps	19.2		9.1		6.2	
	Locked Rotor Amps	162.3		70.8		58.2	
Compressor 2 (Non-Inverter)	Rated Load Amps	22.4		9.1		7.2	
	Locked Rotor Amps	166.2		74.6		54	
Outdoor Fan Motors (3)	Full Load Amps (1 ECM)	2.8		1.4		1.1	
	Full Load Amps (2 Non-ECM)	2.4		1.3		1	
	Total	4.8		2.6		2	
Power Exhaust (2) 0.33 HP	Full Load Amps	2.4		1.3		1	
	Total	4.8		2.6		2	
Service Outlet 115V GFI (amps)		15		15		20	
Indoor Blower Motor	HP	3	5	3	5	3	5
	Full Load Amps	10.6	16.7	4.8	7.6	3.9	6.1
² Maximum Overcurrent Protection (MOCP)	Unit Only	80	90	35	40	25	30
	With (2) 0.33 HP Power Exhaust	90	90	40	40	30	30
³ Minimum Circuit Ampacity (MCA)	Unit Only	66	72	30	33	23	25
	With (2) 0.33 HP Power Exhaust	71	77	32	35	25	27

ELECTRICAL DATA
15 TON

Model		LGT180H5								
¹ Voltage - 60Hz		208/230V - 3 Ph			460V - 3 Ph			575V - 3 Ph		
Compressor 1 (Non-Inverter)	Rated Load Amps	13.1			6.6			4.8		
	Locked Rotor Amps	93			60			41		
Compressor 2 (Non-Inverter)	Rated Load Amps	13.1			6.6			4.8		
	Locked Rotor Amps	93			60			41		
Compressor 3 (Non-Inverter)	Rated Load Amps	13.1			6.6			4.8		
	Locked Rotor Amps	93			60			41		
Outdoor Fan Motors (4)	Full Load Amps (2 ECM)	2.8			1.4			1.1		
	Total	5.6			2.8			2.2		
	Full Load Amps (2 Non-ECM)	2.4			1.3			1		
	Total	4.8			2.6			2		
Power Exhaust (2) 0.33 HP	Full Load Amps	2.4			1.3			1		
	Total	4.8			2.6			2		
Service Outlet 115V GFI (amps)		15			15			20		
Indoor Blower Motor	HP	3	5	7.5	3	5	7.5	3	5	7.5
	Full Load Amps	10.6	16.7	24.2	4.8	7.6	3.9	6.1	6.1	9
² Maximum Overcurrent Protection (MOCP)	Unit Only	70	80	100	35	40	25	30	30	35
	With (2) 0.33 HP Power Exhaust	80	90	100	40	40	30	30	30	40
³ Minimum Circuit Ampacity (MCA)	Unit Only	64	71	80	32	35	24	27	27	30
	With (2) 0.33 HP Power Exhaust	69	76	85	35	38	26	29	29	32

NOTE - All units have a minimum Short Circuit Current Rating (SCCR) of 5000 amps.

¹ Extremes of operating range are plus and minus 10% of line voltage.

² HACR type breaker or fuse.

³ Refer to National or Canadian Electrical Code manual to determine wire, fuse and disconnect size requirements.

⁴ Factory installed circuit breaker not available.

ELECTRICAL DATA

17.5 TON

Model		LGT210H5								
¹ Voltage - 60Hz		208/230V - 3 Ph			460V - 3 Ph			575V - 3 Ph		
Compressor 1 (Non-Inverter)	Rated Load Amps	13.5			6.4			5.1		
	Locked Rotor Amps	120.4			50			41		
Compressor 2 (Non-Inverter)	Rated Load Amps	13.5			6.4			5.1		
	Locked Rotor Amps	120.4			50			41		
Compressor 3 (Non-Inverter)	Rated Load Amps	13.5			6.4			5.1		
	Locked Rotor Amps	120.4			50			41		
Compressor 4 (Non-Inverter)	Rated Load Amps	13.5			6.4			5.1		
	Locked Rotor Amps	120.4			50			41		
Outdoor Fan Motors (4)	Full Load Amps (2 ECM)	2.8			1.4			1.1		
		5.6			2.8			2.2		
	Full Load Amps (2 Non-ECM)	2.4			1.3			1		
		4.8			2.6			2		
Power Exhaust (2) 0.33 HP	Full Load Amps	2.4			1.3			1		
	Total	4.8			2.6			2		
Service Outlet 115V GFI (amps)		15			15			20		
Indoor Blower Motor	HP	3	5	7.5	3	5	7.5	3	5	7.5
	Full Load Amps	10.6	16.7	24.2	4.8	7.6	11	3.9	6.1	9
² Maximum Overcurrent Protection (MOCP)	Unit Only	90	100	110	40	45	50	30	35	40
	With (2) 0.33 HP Power Exhaust	90	100	110	45	50	50	35	40	45
³ Minimum Circuit Ampacity (MCA)	Unit Only	79	86	95	38	41	45	30	33	36
	With (2) 0.33 HP Power Exhaust	84	91	100	40	44	48	32	35	38

ELECTRICAL DATA

20 TON

Model		LGT240H5								
¹ Voltage - 60Hz		208/230V - 3 Ph			460V - 3 Ph			575V - 3 Ph		
Compressor 1 (Non-Inverter)	Rated Load Amps	13.1			6.6			4.8		
	Locked Rotor Amps	93			60			41		
Compressor 2 (Non-Inverter)	Rated Load Amps	13.1			6.6			4.8		
	Locked Rotor Amps	93			60			41		
Compressor 3 (Non-Inverter)	Rated Load Amps	13.1			6.6			4.8		
	Locked Rotor Amps	93			60			41		
Compressor 4 (Non-Inverter)	Rated Load Amps	13.1			6.6			4.8		
	Locked Rotor Amps	93			60			41		
Outdoor Fan Motors (6)	Full Load Amps (2 ECM)	2.8			1.4			1.1		
		5.6			2.8			2.2		
	Full Load Amps (4 Non-ECM)	2.4			1.3			1		
		9.6			5.2			4		
Power Exhaust (2) 0.33 HP	Full Load Amps	2.4			1.3			1		
	Total	4.8			2.6			2		
Service Outlet 115V GFI (amps)		15			15			20		
Indoor Blower Motor	HP	5	7.5	10	5	7.5	10	5	7.5	10
	Full Load Amps	10.6	16.7	24.2	4.8	7.6	11	3.9	6.1	9
² Maximum Overcurrent Protection (MOCP)	Unit Only	90	100	110	45	50	50	35	35	45
	With (2) 0.33 HP Power Exhaust	90	100	125	50	50	60	35	40	45
³ Minimum Circuit Ampacity (MCA)	Unit Only	82	89	98	41	44	49	31	34	37
	With (2) 0.33 HP Power Exhaust	87	94	103	44	47	51	33	36	39

NOTE - All units have a minimum Short Circuit Current Rating (SCCR) of 5000 amps.

¹ Extremes of operating range are plus and minus 10% of line voltage.

² HACR type breaker or fuse.

³ Refer to National or Canadian Electrical Code manual to determine wire, fuse and disconnect size requirements.

⁴ Factory installed circuit breaker not available.

ELECTRICAL DATA

25 TON

Model		LGT300H5								
		208/230V - 3 Ph			460V - 3 Ph			575V - 3 Ph		
¹ Voltage - 60Hz										
Compressor 1 (Non-Inverter)	Rated Load Amps	21.2			9.1			7.7		
	Locked Rotor Amps	156.5			74.8			47.8		
Compressor 2 (Non-Inverter)	Rated Load Amps	21.2			9.1			7.7		
	Locked Rotor Amps	156.5			74.8			47.8		
Compressor 3 (Non-Inverter)	Rated Load Amps	22.4			9.1			7.2		
	Locked Rotor Amps	166.2			74.6			54		
Compressor 4	Rated Load Amps	22.4			9.1			7.2		
	Locked Rotor Amps	166.2			74.6			54		
Outdoor Fan Motors (6)	Full Load Amps (2 ECM)	2.8			1.4			1.1		
		5.6			2.8			2.2		
	Full Load Amps (4 Non-ECM)	2.4			1.3			1		
		9.6			5.2			4		
Power Exhaust (2) 0.33 HP	Full Load Amps	2.4			1.3			1		
	Total	4.8			2.6			2		
Service Outlet 115V GFI (amps)		15			15			20		
Indoor Blower Motor	HP	5	7.5	10	5	7.5	10	5	7.5	10
	Full Load Amps	16.7	24.2	30.8	7.6	11	14	6.1	9	11
² Maximum Overcurrent Protection (MOCP)	Unit Only	125	150	150	60	60	70	50	50	60
	With (2) 0.33 HP Power Exhaust	150	150	175	60	70	70	50	50	60
³ Minimum Circuit Ampacity (MCA)	Unit Only	125	133	141	55	59	62	45	48	50
	With (2) 0.33 HP Power Exhaust	130	138	146	57	61	65	47	50	52

NOTE - All units have a minimum Short Circuit Current Rating (SCCR) of 5000 amps.

¹ Extremes of operating range are plus and minus 10% of line voltage.

² HACR type breaker or fuse.

³ Refer to National or Canadian Electrical Code manual to determine wire, fuse and disconnect size requirements.

⁴ Factory installed circuit breaker not available.

ELECTRICAL ACCESSORIES

DISCONNECTS

Voltage	208V	240V	208V	240V	208V	240V	460V			575V		
Model No.	LGT156H5											
Blower Motor HP	3		5		---		3	5	---	3	5	---
Unit Only	54W88	54W88	54W88	54W88	---	---	54W88	54W88	---	54W88	54W88	---
Unit w/ Power Exhaust	54W88	54W88	54W89	54W88	---	---	54W88	54W88	---	54W88	54W88	---
Model No.	LGT180H5											
Blower Motor HP	3		5		7.5		3	5	7.5	3	5	7.5
Unit Only	54W88	54W88	54W88	54W88	54W89	54W89	54W88	54W88	54W88	54W88	54W88	54W88
Unit w/ Power Exhaust	54W88	54W88	54W89	54W89	54W89	54W89	54W88	54W88	54W88	54W88	54W88	54W88
Model No.	LGT210H5											
Blower Motor HP	3		5		7.5		3	5	7.5	3	5	7.5
Unit Only	54W89	54W89	54W89	54W89	54W89	54W89	54W88	54W88	54W88	54W88	54W88	54W88
Unit w/ Power Exhaust	54W89	54W89	54W89	54W89	54W89	54W89	54W88	54W88	54W88	54W88	54W88	54W88
Model No.	LGT240H5											
Blower Motor HP	5		7.5		10		5	7.5	10	5	7.5	10
Unit Only	54W89	54W89	54W89	54W89	54W89	54W89	54W88	54W88	54W88	54W88	54W88	54W88
Unit w/ Power Exhaust	54W89	54W89	54W89	54W89	54W89	54W89	54W88	54W88	54W88	54W88	54W88	54W88
Model No.	LGT300H5											
Blower Motor HP	5		7.5		10		5	7.5	10	5	7.5	10
Unit Only	54W89	54W89	54W89	54W89	90W82	90W82	54W88	54W88	54W88	54W88	54W88	54W88
Unit w/ Power Exhaust	54W89	54W89	90W82	90W82	90W82	90W82	54W88	54W88	54W88	54W88	54W88	54W88

Disconnects - 54W88 - 80A
 54W89 - 150A
 90W82 - 250A

FIELD WIRING NOTES

- For use with copper wiring only
- Field wiring not furnished
- All wiring must conform to NEC or CEC and local electrical codes
- For specific wiring information, please refer to the installation instructions

INSTALLATION CLEARANCES

Unit With Economizer

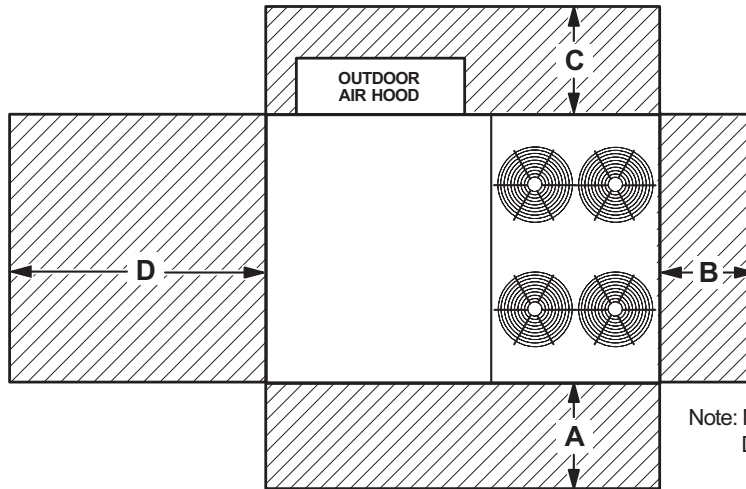

Note: Models with four outdoor fans shown.
Dimension clearances are for all sizes.

¹ Unit Clearance	A		B		C		D		Top Clearance
	in.	mm	in.	mm	in.	mm	in.	mm	
Service Clearance	60	1524	36	914	36	934	66	1676	Unobstructed
Clearance to Combustibles	36	914	1	25	1	25	1	25	
Minimum Operation Clearance	45	1143	36	914	36	914	41	1041	

NOTE - Entire perimeter of unit base requires support when elevated above the mounting surface.

¹ Service Clearance - Required for removal of serviceable parts.

Clearance to Combustibles - Required clearance to combustible material.

Minimum Operation Clearance - Required clearance for proper unit operation.

OUTDOOR SOUND DATA

Size	Octave Band Sound Power Levels dBA, re 10 ⁻¹² Watts - Center Frequency - Hz							¹ Sound Rating Number (dBA)
	125	250	500	1000	2000	4000	8000	
156	71	78	81	81	76	71	63	86
180	80	83	87	88	84	80	71	93
210, 240, 300	79	84	88	89	85	82	73	94

Note - The octave sound power data does not include tonal corrections.

¹ Sound Rating Number according to AHRI Standard 370-2001 (includes pure tone penalty). Sound Rating Number is the overall A-Weighted Sound Power Level, (LWA), dBA (100 Hz to 10,000 Hz).

WEIGHT DATA				UNIT	
Model Number	Net		Shipping		
	lbs.	kg	lbs.	kg	
156 Base Unit	2014	914	2214	1005	
156 Max. Unit	2299	1044	2499	1135	
180 Base Unit	2128	966	2328	1057	
180 Max. Unit	2413	1096	2613	1186	
210 Base Unit	2569	1166	2769	1257	
210 Max. Unit	2854	1296	3054	1386	
240 Base Unit	2601	1181	2801	1271	
240 Max. Unit	2886	1310	3086	1400	
300 Base Unit	2651	1204	2851	1294	
300 Max. Unit	2936	1333	3136	1424	

Max. Unit - The unit with ALL INTERNAL OPTIONS Installed. (Economizer, Standard Static Power Exhaust Fans, Controls, etc.). Does not include accessories external to unit.

FACTORY / FIELD INSTALLED OPTIONS AND ACCESSORIES - NET WEIGHTS			
Description		lbs.	kg
ECONOMIZER / OUTDOOR AIR / EXHAUST			
Economizer			
Economizer Dampers (with Outdoor Air Hood)		167	76
Barometric Relief Dampers (downflow)		30	14
Barometric Relief Dampers (horizontal)		20	9
Outdoor Air Dampers with Hood (downflow)			
Motorized		39	18
Manual		22	10
Power Exhaust		62	28
GAS HEAT EXCHANGER (NET WEIGHT)			
Medium Heat (adder over standard heat)		18	8
High Heat (adder over standard heat)		64	29
COMBINATION COIL/HAIL GUARDS			
156		30	13
180-300		36	16
ROOF CURBS			
Hybrid Roof Curbs, Downflow			
8 in. height		136	62
14 in. height		169	77
18 in. height		191	87
24 in. height		224	102
Adjustable Pitch Curb, Downflow			
14 in. height		224	102
Horizontal, Standard			
26 in. height		450	204
37 in. height		540	245
30 in. height		495	225
41 in. height		575	261
CEILING DIFFUSERS			
Step-Down	RTD11-185S	168	76
	RTD11-275S	238	108
Flush	FD11-185S	168	76
	FD11-275S	238	108
Transitions	C1DIFF33C-1	80	36
	C1DIFF34C-1	75	34
HUMIDITROL® DEHUMIDIFICATION SYSTEM			
Humiditrol® Dehumidification Option		50	23

DIMENSIONS

156

CORNER WEIGHTS

CENTER OF GRAVITY

Model	AA		BB		CC		DD		EE		FF	
	lbs.	kg	lbs.	kg	lbs.	kg	lbs.	kg	in.	mm	in.	mm
LGT156 Base Unit	481	219	399	181	514	234	620	282	48-7/8	1241	39-3/4	1011
LGT156 Max. Unit	596	271	487	221	547	248	669	304	48-1/2	1230	43	1090

Base Unit - The unit with NO INTERNAL OPTIONS.

Max. Unit - The unit with ALL INTERNAL OPTIONS Installed. (Economizer, Standard Static Power Exhaust Fans, Controls, etc.). Does not include accessories external to unit.

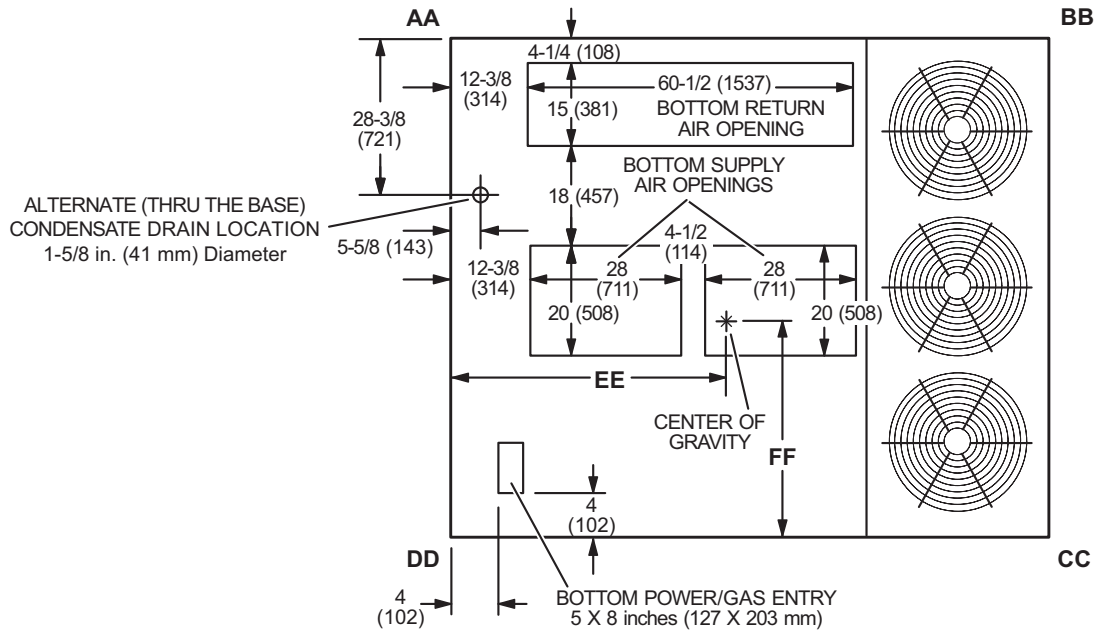

TOP VIEW

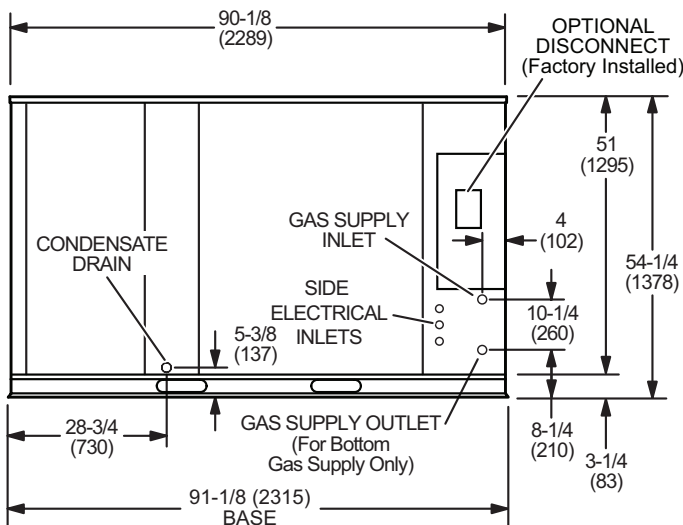

END VIEW

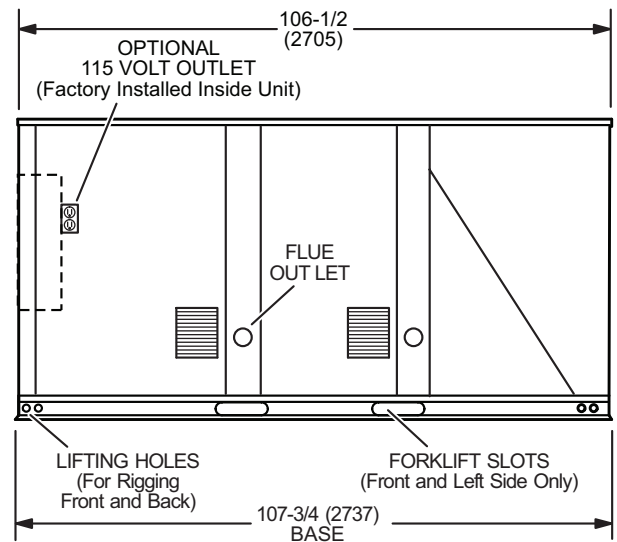

SIDE VIEW

CORNER WEIGHTS

CENTER OF GRAVITY

Model	AA		BB		CC		DD		EE		FF	
	lbs.	kg	lbs.	kg	lbs.	kg	lbs.	kg	in.	mm	in.	mm
LGT180 Base Unit	483	219	435	198	574	261	636	289	51	1298	39-1/4	998
LGT180 Max. Unit	596	271	517	235	604	275	696	316	50	1272	42	1068
LGT210 Base Unit	512	233	620	282	787	358	650	296	59	1498	40-1/8	1020
LGT210 Max. Unit	624	283	709	322	809	368	712	324	57-3/8	1456	42-1/2	1081

Base Unit - The unit with NO INTERNAL OPTIONS.

Max. Unit - The unit with ALL INTERNAL OPTIONS Installed. (Economizer, Standard Static Power Exhaust Fans, Controls, etc.). Does not include accessories external to unit.

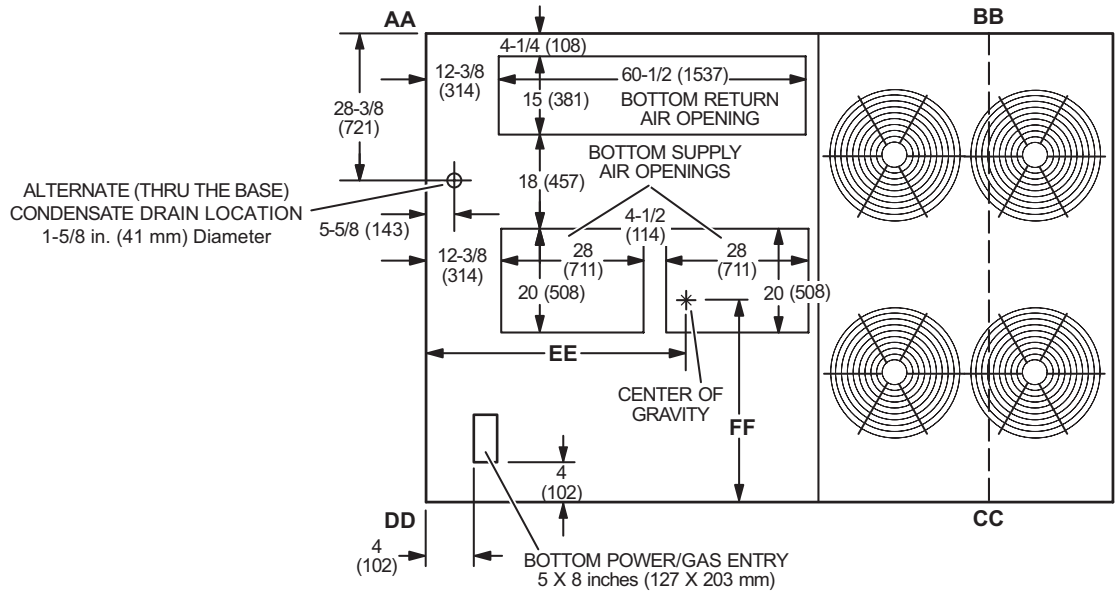

TOP VIEW

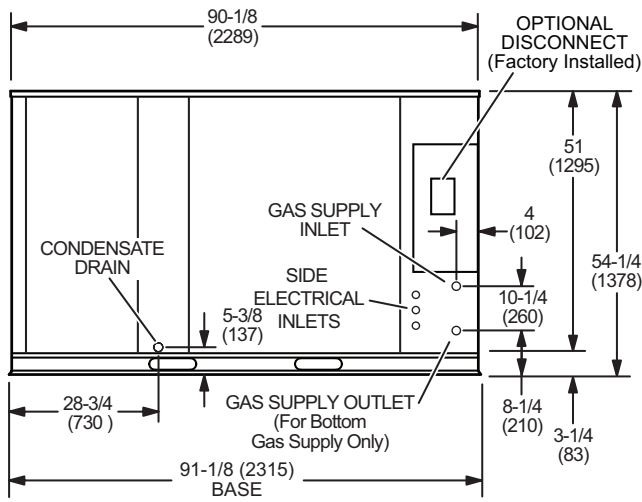

END VIEW

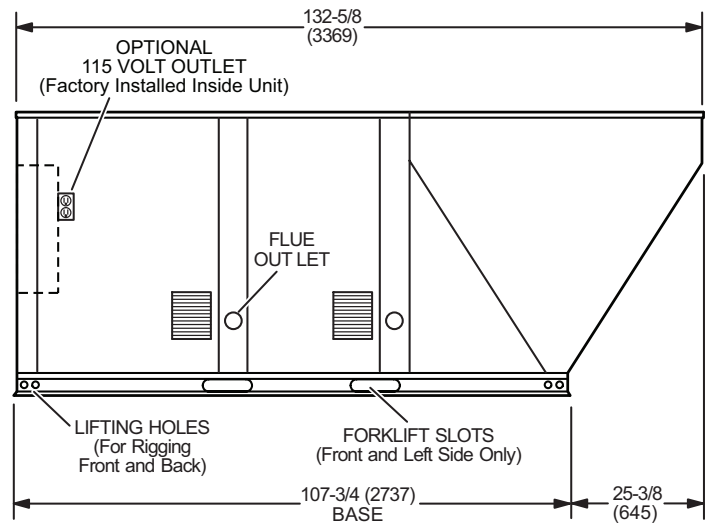

SIDE VIEW

CORNER WEIGHTS

CENTER OF GRAVITY

Model	AA		BB		CC		DD		EE		FF	
	lbs.	kg	lbs.	kg	lbs.	kg	lbs.	kg	in.	mm	in.	mm
LGT240 Base Unit	519	236	611	278	796	362	676	307	58-1/4	1480	39-1/2	1005
LGT240 Max. Unit	628	286	702	319	821	373	735	334	56-7/8	1444	42	1067
LGT300 Base Unit	526	239	598	272	812	369	714	325	57-3/8	1456	38-5/8	982
LGT300 Max. Unit	633	288	686	312	841	382	776	353	56	1423	41	1040

Base Unit - The unit with NO INTERNAL OPTIONS.

Max. Unit - The unit with ALL INTERNAL OPTIONS Installed. (Economizer, Standard Static Power Exhaust Fans, Controls, etc.). Does not include accessories external to unit.

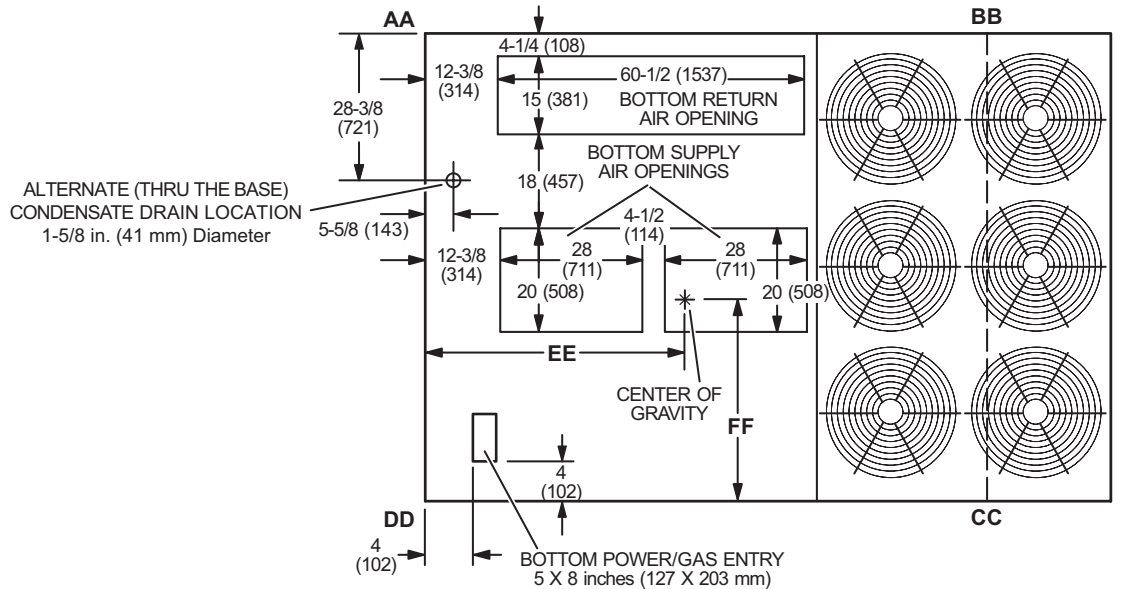

TOP VIEW

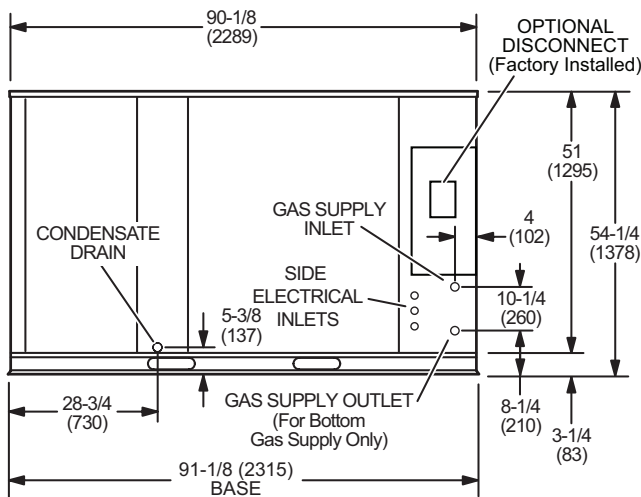

END VIEW

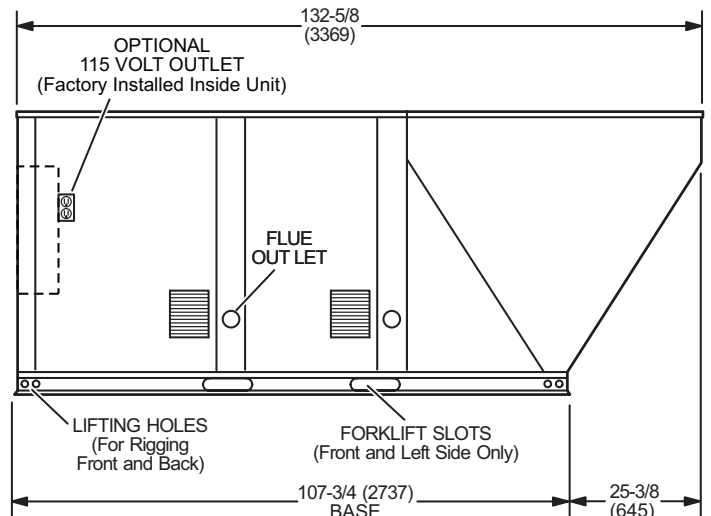

SIDE VIEW

OUTDOOR AIR HOOD DETAIL

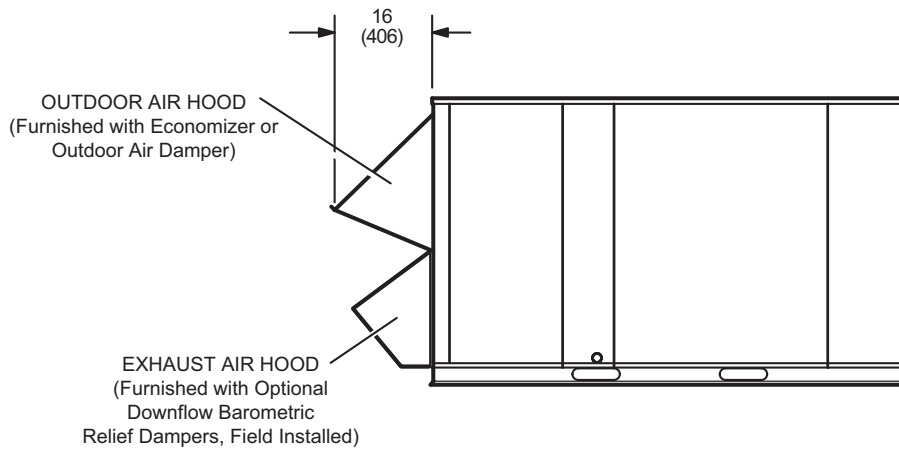

OPTIONAL HORIZONTAL BAROMETRIC RELIEF DAMPERS WITH HOOD

(Field installed in horizontal return air duct adjacent to unit)

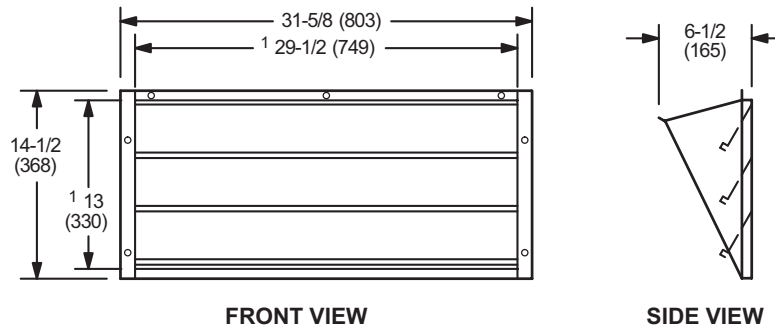

NOTE - Two furnished per order no.
¹ NOTE - Opening size required in return air duct.

HYBRID ROOF CURBS - DOUBLE DUCT OPENING

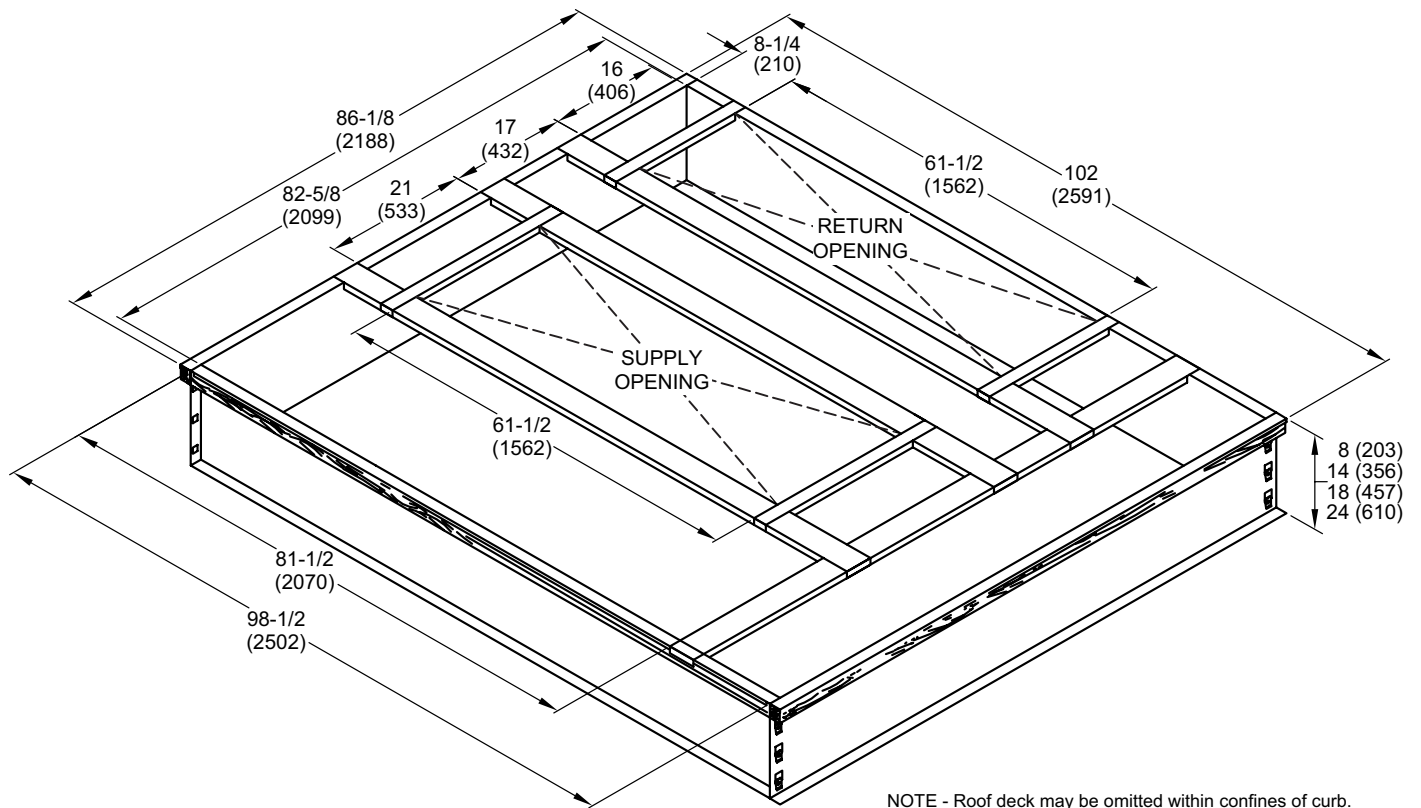

TYPICAL FLASHING DETAIL FOR ROOF CURB

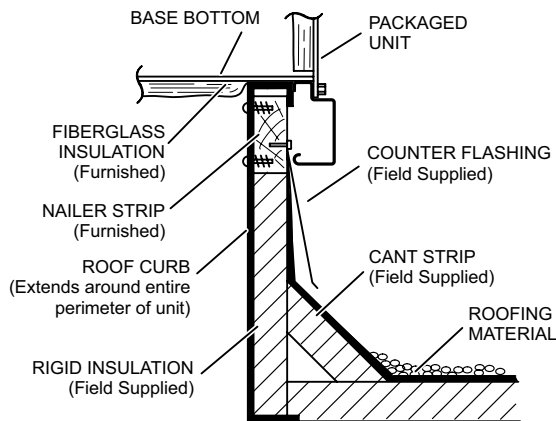

DETAIL ROOF CURB

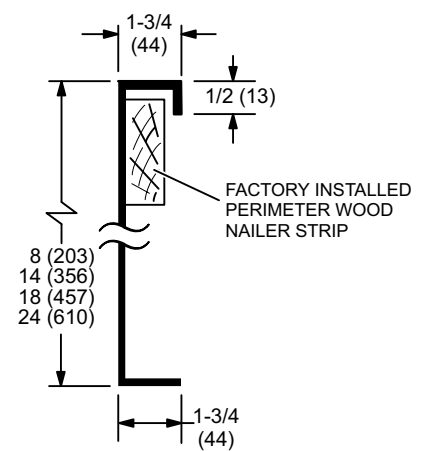

ADJUSTABLE PITCH CURB - DOUBLE DUCT OPENING

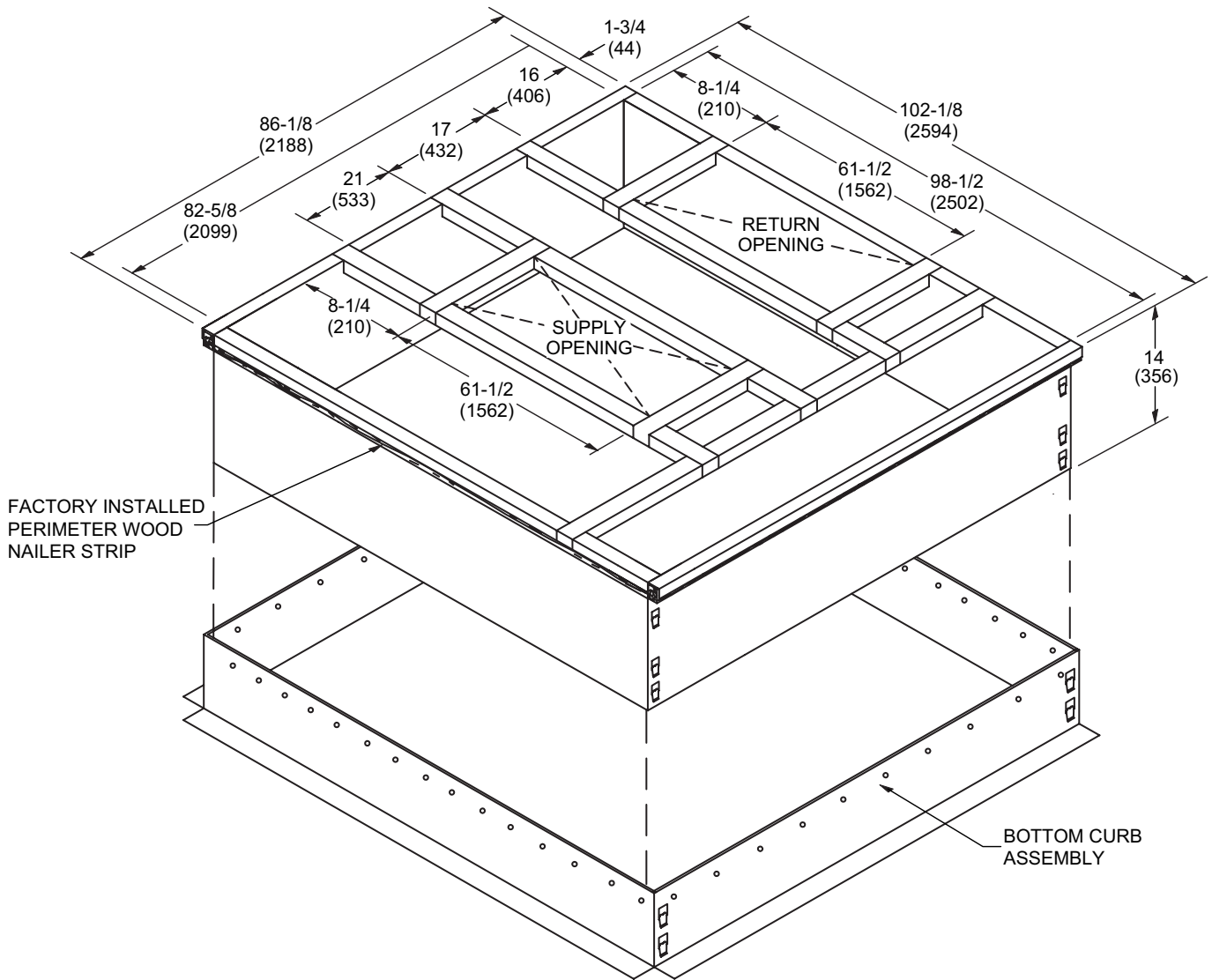

NOTE - Maximum slope pitch is 3/4 in. per 1 foot (19 mm per 305 mm) in any one direction.

TYPICAL FLASHING DETAIL FOR ROOF CURB

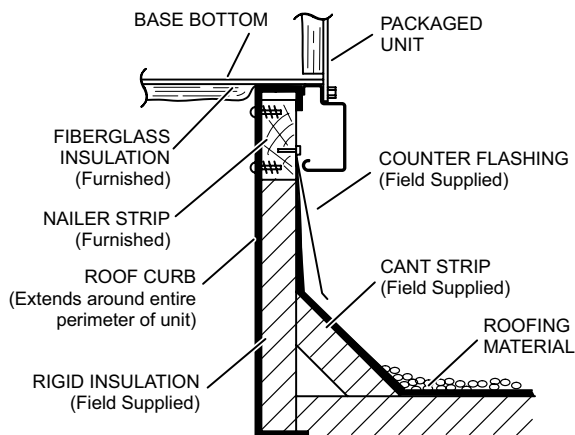

DETAIL ROOF CURB

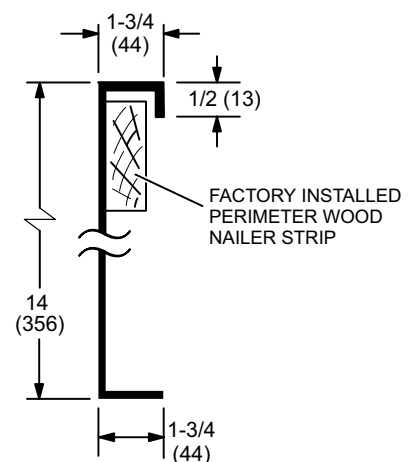

ROOF CURBS WITH SUPPLY & RETURN AIR TRANSITIONS FOR CEILING DIFFUSERS

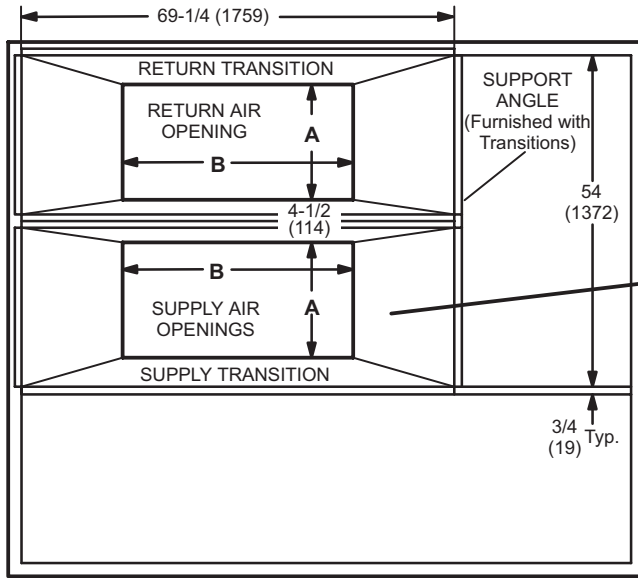

TOP VIEW

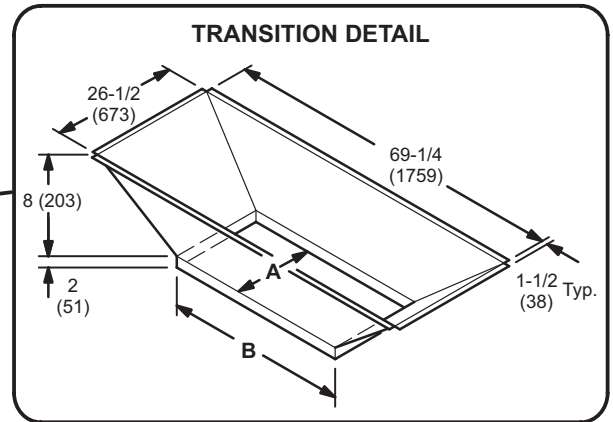

TRANSITION OPENING SIZES

Model Number	A		B	
	inch	mm	inch	mm
C1DIFF33C-1	18	457	36	914
C1DIFF34C-1	24	610	48	1219

HORIZONTAL ROOF CURBS – Requires Optional Horizontal Return Air Panel Kit

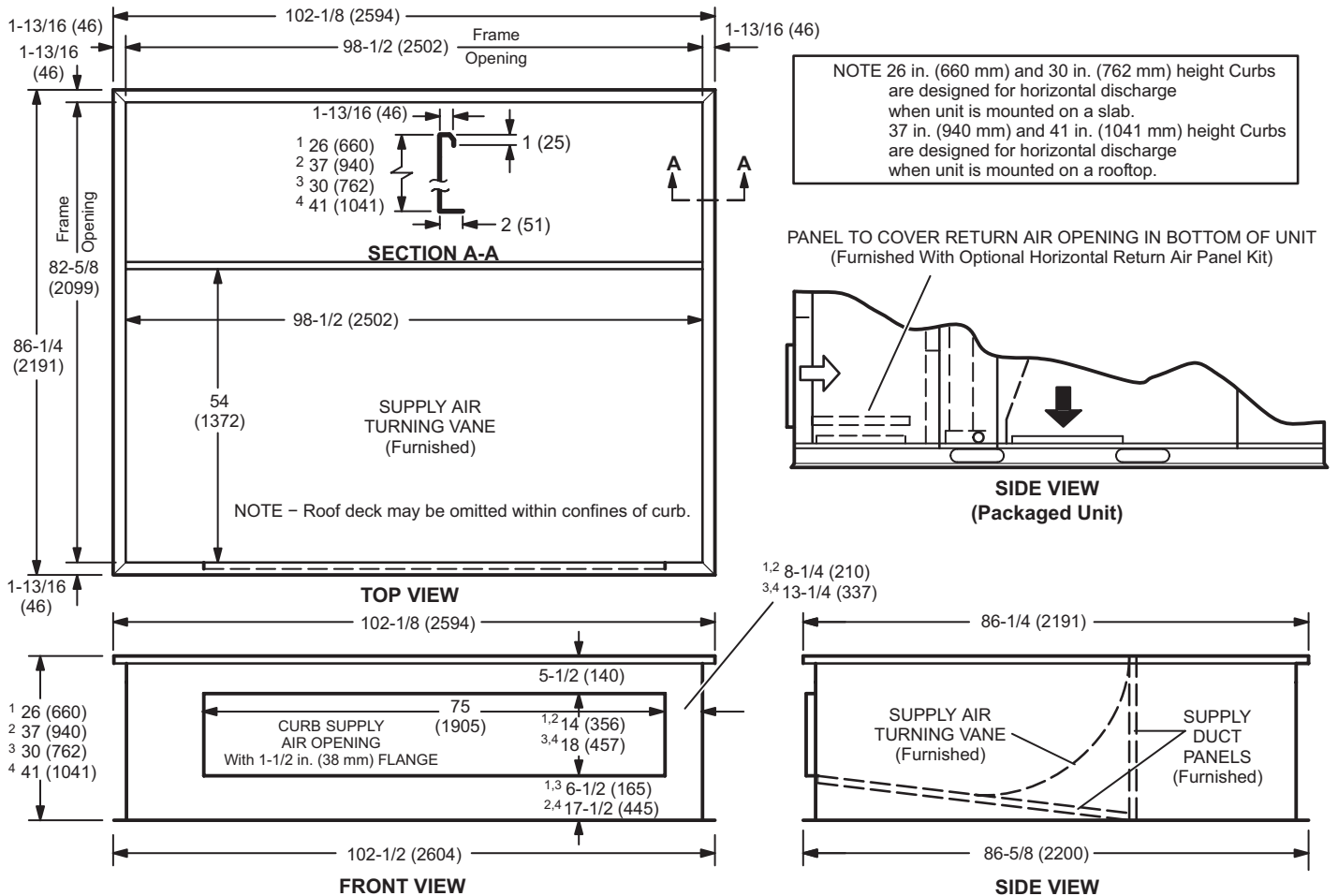

1 Slab Applications 2 Rooftop Applications 3 Slab Applications (used with 300) 4 Rooftop Applications (used with 300)

HORIZONTAL SUPPLY AND RETURN AIR OPENINGS WITH HORIZONTAL ROOF CURB

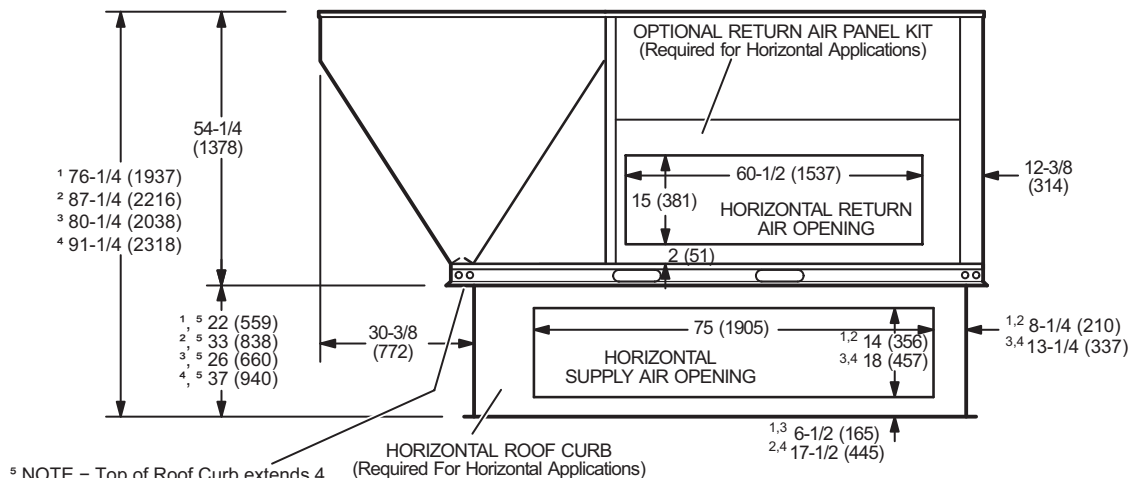

1 Slab Applications
2 Rooftop Applications
3 Slab Applications (used with 300 Models Only)
4 Rooftop Applications (used with 300 Models Only)

COMBINATION CEILING SUPPLY AND RETURN DIFFUSERS

STEP-DOWN CEILING DIFFUSER

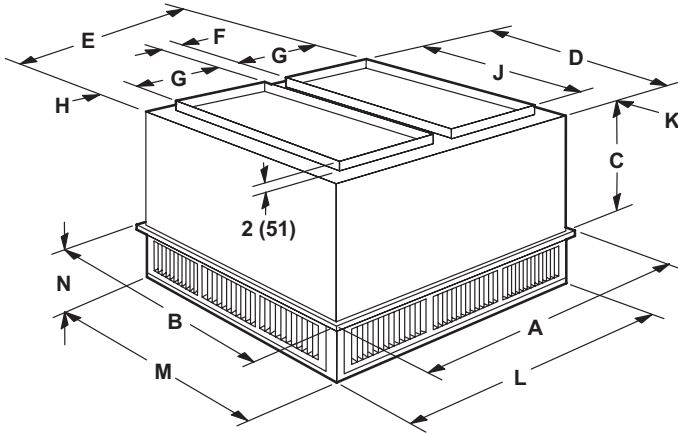

FLUSH CEILING DIFFUSER

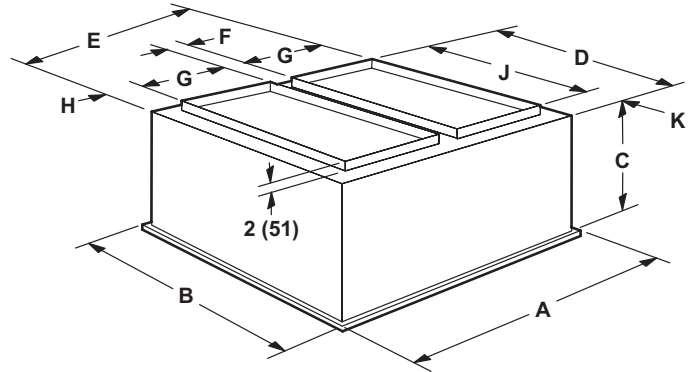

Model		RTD11-185S	RTD11-275S
A	in.	47-5/8	59-5/8
	mm	1210	1514
B	in.	47-5/8	59-5/8
	mm	1210	1514
C	in.	24-5/8	30-5/8
	mm	625	778
D	in.	45-1/2	57-1/2
	mm	1156	1461
E	in.	45-1/2	57-1/2
	mm	1156	1461
F	in.	4-1/2	4-1/2
	mm	114	114
G	in.	18	24
	mm	457	610
H	in.	2-1/2	2-1/2
	mm	64	64
J	in.	36	48
	mm	914	1219
K	in.	4-3/4	4-3/4
	mm	121	121
L	in.	45-1/2	57-1/2
	mm	1156	1461
M	in.	45-1/2	57-1/2
	mm	1156	1461
N	in.	10-1/8	11-1/8
	mm	257	283
Duct Size	in.	18 x 36	24 x 48
	mm	457 x 914	610 x 1219

Model		FD11-185S	FD11-275S
A	in.	47-5/8	59-5/8
	mm	1210	1514
B	in.	47-5/8	59-5/8
	mm	1210	1514
C	in.	29-1/4	35-1/4
	mm	743	895
D	in.	45	57
	mm	1143	1148
E	in.	45	57
	mm	1143	1448
F	in.	4-1/2	4-1/2
	mm	114	114
G	in.	18	24
	mm	457	610
H	in.	2-1/4	2-1/4
	mm	57	57
J	in.	36	48
	mm	914	1219
K	in.	4-1/2	4-1/2
	mm	114	114
Duct Size	in.	18 x 36	24 x 48
	mm	457 x 914	610 x 1219

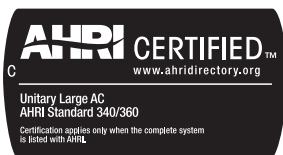

Visit us at www.Lennox.com

For the latest technical information, www.LennoxCommercial.com

Contact us at 1-800-4-LENNOX

NOTE - Due to Lennox' ongoing commitment to quality, Specifications, Ratings and Dimensions subject to change without notice and without incurring liability. Improper installation, adjustment, alteration, service or maintenance can cause property damage or personal injury. Installation and service must be performed by a qualified installer and servicing agency.

©2024 Lennox Industries, Inc.